

Superior Curing Technology

IRT[®]
SYSTEM
Hyperion



IRT SYSTEM

Hyperion

- New and practical design
- Short curing times
- Large curing area – even heat distribution
- Gold-coated FreeForm reflectors
- Increased efficiency
- Reduced energy consumption
- Environmentally friendly



IRT HYPERION

advanced technology – new design

The Hyperion program offers a wide selection of IR dryers. As always when dealing with IRT products, each model has its own particular area of use.

IRT – The original in a new suit

The Hyperion family does not resemble previous IRT products.

Every part in a Hyperion dryer is based on a well thought-out and tested design based on user-friendliness and capacity.

The new smart foot design even allows it to get under low cars and it is possible to place the mobile dryer around a wheel.

Another example of the well thought-out design is the stand arm on the large models. It has acquired the characteristic Hyperion angle in order for the cassettes to reach above the roof of high vehicles or an SUV and still stand steady and stable on the floor.

Moving a mobile Hyperion around the workshop is really easy thanks to its low centre of gravity. It is easy to aim the cassettes at the surface to be cured as the arm is well-levelled and balanced.

The market's most effective reflectors

We are the only company having gold-coated reflectors behind the short-wave lamps. For this reason, our IR dryers have unsurpassed drying capacity. The new Hyperion FreeForm reflectors provide a more even heat distribution and a larger curing area than conventional reflectors, while they feature reduced power consumption. In turn, this increases productivity and raises the quality of the result of drying.

Environmentally friendly

The Hyperion dryers irradiate the object and do not heat the surrounding air thereby minimising energy losses. This provides an efficient use of energy and shortens drying times, which is good for the environment.

Time to cure paint

After 40 years in the industry, we know what is important and what the customer wants. Our most advanced Hyperion models are the easiest ones to handle.

With 12 preset and 3 custom programs, you can handle all paint materials on the market. Thanks to the easily understandable and self-instructional menus, program selection is quick and easy. If you want, you can go one step further and create your own program settings. You will continuously be able to follow the curing process on the control unit display.

Start the control unit, select a program – then dry.

This is as difficult as it gets with advanced and user friendly technology.

**IRT Hyperion
Superior Curing Technology**





We are setting a new standard with IRT Hyperion PcAuto & PcD

FreeForm reflectors

With the introduction of the new, gold-coated, asymmetric FreeForm reflectors, we have developed the reflectors of the future. Increased heat distribution provides a more even heat distribution implying that a larger area can be cured during the same period.

A lot of energy is saved by only irradiating the object and not heating up the surrounding air. All cables from the stand to the cassettes are enclosed. You avoid loose cables that can be burned or cause scratches in the paint, leaving your hands free to move the dryer.

Cassette/lamps

There are two things that shorten the service life of an IR lamp: overheating and dust. An IRT lamp should last for 20,000 operating hours. For this reason, the Hyperion cassettes are equipped with powerful ventilation cooling both lamps and cassettes. This extends the life of the lamps significantly. The problems with dust have been resolved with a new, effective particle filter on the rear of the cassette. The software informs the operator of how much cleaning capacity is left in the particle filter and when it is time for the next filter replacement.

Stand

Thanks to the special angle of the arm and the advanced design of the foot, curing is possible in places that were previously inaccessible.

IRT Hyperion reaches higher than any other mobile dryer, 2,250 mm with the cassette in the horizontal position and approx. 2,550 mm in the vertical position.

The new smart foot design even allows it to get under low cars and it is possible to place the mobile dryer around a wheel. The mobile unit's large and well-balanced wheels roll unhindered of floor gratings



and easily cope with air hoses and other obstacles on the workshop floor.

Control unit

The most advanced Hyperion models are equipped with advanced technology such as a temperature measurement, laser circle and digital distance sensor. The functions are easy to understand and use – even on the most advanced models. There is a program for each drying requirement. It is started with the simple press of a button. 18 different languages can easily be set. The display is clear and its brightness can be regulated. The laser circle shows where the measurement of the temperature on the curing area takes place, and the ultra-

sound sensor measures the distance and signals when the distance is correct. The temperature is continuously measured, while the microprocessor regulates the effective output upwards or downwards in a split second for optimal curing results.

As an operator, you can continuously monitor the curing process and receive information about such things as object temperature and elapsed/remaining program time.

Start the control unit, select a program then dry.



Easy to understand – easy to use



Our smart Hyperion rail systems will increase your productivity

The same capacity as in our advanced mobile dryers

Our rail systems satisfy the highest requirements for high productivity and superior precision. For this reason, we have further developed our two most advanced Hyperion models to rail systems. The capacity is the same as in the IRT 4-2 PcAuto and IRT 3-2 PcD, but the cassettes are suspended in the air on rails instead of standing on the floor. IRT 3-20 PcD and IRT 4-20 PcAuto are used in the prep station. The IRT 4-20 PcAuto can be supplemented with monitoring equipment in order to enable safe use in a spray booth.

Rails

The rails can be customized to suit all workshops. The cassettes are suspended in arms that glide easily and are self-balancing. As the electric power supply is integrated in the rails, there are no loose

cables dragging along the floor disrupting work and raking up dust.

Cost-effective

Investing in a rail system is a way for a paint shop to eliminate bottlenecks in production and substantially increase productivity. Energy costs will be lower and valuable workshop space will be freed up.

A rail system constitutes a flexible solution. It is just as practical in a spray booth as in the prep station.

Advantages

- Simple installation.
- Easy to move and set up in an exact position
- More flexible workshop
- No cables on the floor – free areas
- Excellent fit in tight areas between cars



By angling each cassette in its own direction, two cars can be dried at the same time.



The reach is so great that it is possible to even dry the sill and the underside of the car.



Even the smallest Hyperion models are very efficient

The smaller Hyperion models have the same high quality as the advanced IRT dryers, but are somewhat simpler as regards function and design.

Common characteristics for all Hyperion dryers:

- Short-wave lamps
- Gold-coated FreeForm reflectors
- Powerful ventilation
- Increased heat propagation
- Even heat distribution
- Large drying areas

IRT 3 PrepCure and IRT 4 PrepCure are ideal for use in the prep station. Both are equipped with a compact cassette that is controlled by two manual timers – Flash off up to 30 minutes, Full bake up to 30 minutes. The cassette is balanced with a gas-filled

damper and can easily be operated with one hand. With IRT 4 PrepCure, you can reach a height of 2,150 mm, enabling curing of car roofs on high cars.



IRT 1 PrepCure and IRT 2 PrepCure are excellent aids for body shops. They can be used to heat small areas or for quick drying of putty, filler and clear coat as well as for applying and removing stickers.

IRT 1 and IRT 2 can either be used



as hand-held dryers or be mounted on stands. By holding the dryer in your hand you can cure areas that are difficult to reach. The On/Off button is integrated in the stable handle.

The stand has a timer that can be set to a maximum of 120 minutes. A holder on the stand allows for both vertical and horizontal drying.

IRT Hyperion – a dryer for ever



IRT 3-20 PcD & IRT 4-20 PcAuto

Rail systems adapted for the prep station or the spray booth. The dryer is suspended in permanently installed rails and can be moved laterally and vertically in all directions. (The same curing capacity as IRT 3-2 PcD and IRT 4-2 PcAuto)

- No cables on the floor - free areas
- Electric power supply integrated into the rails
- Excellent fit in tight areas between cars
- Less risk for unintentional damage to the car
- Unique possibilities to position the cassettes
- Computerised curing process
- Gold-coated FreeForm reflectors for optimal heat distribution
- Pyrometer for exact temperature control (IRT 4-20 only)
- Laser circle indicates where temperature measuring takes place (IRT 4-20 only)
- Electronic distance sensor
- Very easy to use
- 12 preset and 3 custom programs
- Can cure all paint materials
- Efficient particle filter on the cassettes
- Powerful ventilation that cools the cassette and increases lamp life

	3-20 PcD		4-20 PcAuto	
Voltage	220–240 V 3 Ph/PE	380–420 V 3 Ph/PE	220–240 V 3 Ph/PE	380–420 V 3 Ph/PE
Frequency	50–60 Hz	50–60 Hz	50–60 Hz	50–60 Hz
Current	15 A	9 A	30 A	17 A
Output power	6 kW	6 kW	12 kW	12 kW
Fuse	16 A	16 A	32 A	32 A



IRT 4-1 PcAuto & IRT 4-2 PcAuto

These are our most complete mobile dryers with the highest output and capacity. The products are easy to use and the curing times are reduced to a minimum.

- One (6 kW) or two (12 kW) cassettes depending on desired drying surface
- Unique possibilities to position the cassettes
- Gold-coated FreeForm reflectors for optimal heat distribution
- Computerised monitoring of curing
- Pyrometer for exact temperature control
- Laser circle indicates where temperature measuring takes place
- Electronic distance sensor
- Very easy to use
- 12 preset and 3 custom programs
- Can cure all paint materials
- Smart stand design
- Efficient particle filter on the cassettes
- Powerful ventilation that cools the cassette and increases lamp life
- Maximum cassette height 2,250 mm (horizontal), 2,550 mm (vertical)

	4-1 PcAuto		4-2 PcAuto	
Voltage	220–240 V 3 Ph/PE	380–420 V 3 Ph/PE	220–240 V 3 Ph/PE	380–420 V 3 Ph/PE
Frequency	50–60 Hz	50–60 Hz	50–60 Hz	50–60 Hz
Current	15 A	9 A	30 A	16 A
Output power	6 kW	6 kW	12 kW	12 kW
Fuse	16 A	16 A	32 A	16 A

y need ...



IRT 3-1 PcD & IRT 3-2 PcD

These are the standard dryers for all types of workshops. They are mostly used for small to medium-sized repairs and for primers, but have sufficient output to cure all kinds of paint materials. (The same curing capacity as IRT 3-20 PcD.)

- One (3 kW) or two (6 kW) cassettes depending on desired drying surface
- Unique possibilities to position the cassettes
- Gold-coated FreeForm reflectors for optimal heat distribution
- Computerised curing process
- Electronic distance sensor
- Very easy to use
- 12 preset and 3 custom programs
- Can cure all paint materials
- Smart stand design
- Efficient particle filter on the cassettes
- Powerful ventilation that cools the cassette and increases lamp life
- Maximum cassette height 2,250 mm (horizontal), 2,550 mm (vertical)

	3-1 PcD		3-2 PcD	
Voltage	220–240 V 3 Ph/PE	380–420 V 3 Ph/PE	220–240 V 3 Ph/PE	380–420 V 3 Ph/PE
Frequency	50–60 Hz	50–60 Hz	50–60 Hz	50–60 Hz
Current	8 A	5 A	15 A	9 A
Output power	3 kW	3 kW	6 kW	6 kW
Fuse	16 A	16 A	16 A	16 A

PS. why Hyperion

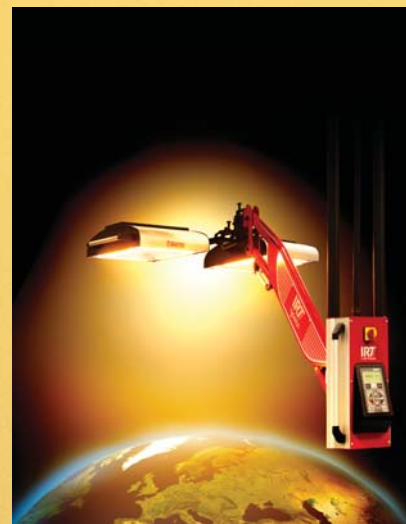

Just like the sun, our new IRT products irradiate light and heat. Since their properties are similar, they have been named of Hyperion, the sun god. The light and heat of the sun is a prerequisite for all life on Earth.

History

Hyperion was the sun god of the Titans in early Greek mythology. He was the son of Uranus (Heaven) and Gaia (Earth) and the father of Helios (the Sun), Eos (the Dawn) and Selene (the Moon).

The name Hyperion means “watcher from above” and originates from the Greek hyper and iôn.

Facts

Hyperion is also a moon in Saturn’s solar system that was discovered in 1848. It is the largest irregularly shaped body in the solar system.

(Read more about our irregular FreeForm reflectors on page 4)

IRT Hyperion – a dryer for every need



IRT 3 PrepCure & IRT 4 PrepCure

These dryers are ideal for curing small to medium-sized surfaces. The products are used to speed up drying of putty, filler, base and clear coat. Using two manual timers, the products are very easy to use.

- 3 kW cassette
- Unique possibilities for positioning the cassettes
- Gold-coated FreeForm reflectors for optimal heat distribution
- Two manual timers:
 - Flash-off 50% output power
 - Full bake 100% output power
- Very easy to use
- Can cure all paint materials
- Efficient particle filter on the cassettes
- Powerful ventilation that cools the cassette and increases lamp life
- Maximum cassette height (IRT 3) 1,300 mm horizontal
- Maximum cassette height (IRT 4) 2,150 mm horizontal



IRT 1 PrepCure & IRT 2 PrepCure

For minor paint and panel work. Can be used as hand-held units. Recommended for surfaces that are otherwise difficult to access. IRT 1 and IRT 2 can also be mounted on a stand equipped with a timer.

- One lamp of 1 kW (IRT 1)
- Two lamps with a total of 2 kW (IRT 2)
- Gold-coated reflectors for optimal heat distribution
- FreeForm reflectors (IRT 2 only)
- Manual timer on the stand (120 minutes)
- Flexible and easy use
- Can cure all base materials and paint materials
- Powerful ventilation that cools the cassette and increases lamp life (IRT 2)
- On/Off button integrated in handle
- Stand height 1,450 mm

	IRT 3 PrepCure	IRT 4 PrepCure
Voltage	220–240 V 1 ph, PE	220–240 V 1 ph, PE
Frequency	50/60 Hz	50/60 Hz
Current	13 A	13 A
Output power	3 kW	3 kW
Fuse	16 A	16 A

	IRT 1 PrepCure	IRT 2 PrepCure
Voltage	220–240 V 1 ph, PE	220–240 V 1 ph, PE
Frequency	50-60 Hz	50-60 Hz
Current	4 A	8 A
Output power	1 kW	2 kW

Technical data

Curing surfaces

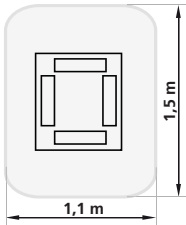

IRT 4-1 PcAuto

One cassette at a distance of 600 mm, on black sheet metal

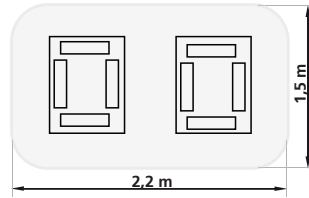

IRT 4-2 PcAuto IRT 4-20 PcAuto

Two cassettes at a distance of 600 mm, on black sheet metal

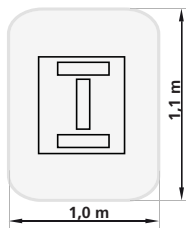

IRT 3-1 PcD IRT3 & 4 PrepCure

One cassette at a distance of 600 mm, on black sheet metal

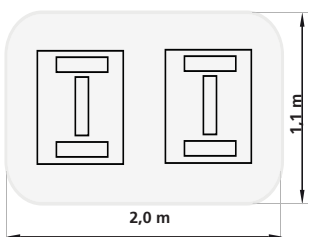

IRT 3-2 PcD IRT 3-20 PcD

Two cassettes at a distance of 600 mm, on black sheet metal

Short-wave for most efficient curing

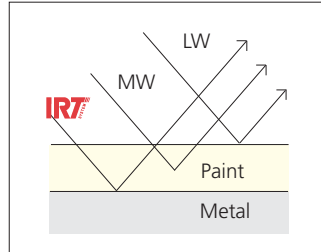

Simplified diagram.

Short-wave heat cures from the inside and out, while medium-wave, long-wave and hot air primarily cure the surface.

All IRT dryers use short-wave technology. This, together with the unique IRT FreeForm reflectors, provides the best heat transfer possible. Short-wave IR has several other advantages. It is easy to control, provides full heat immediately and penetrates deep into the paint. The paint cures from the inside and out without retaining solvents and moisture that gives rise to problems with quality. Heat losses to the air are minimal and all energy is transferred to the surface to be dried.

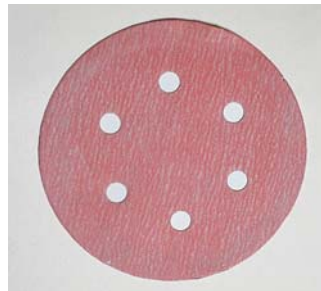

After only 3 minutes' curing you can polish with perfect results.

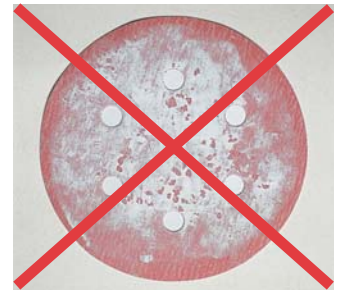

Despite a longer curing time with other products, only the surface is cured and the sanding paper becomes clogged.

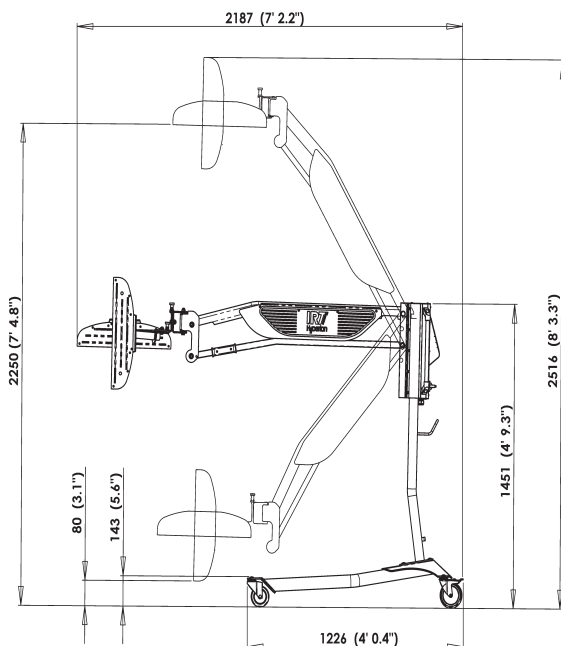

IRT 4-1, 4-2 PcAuto, IRT 3-1, 3-2 PcD

Curing times

	Minutes.
Putty	2-3
Filler	3-7
Primer	5-8
Water-base paint	2-4
Base coat	4-8
Top coat	6-10
Clear coat	5-10
Filler on plastic	7-10
Top coat on plastic	15-18
Clear coat on plastic	15-18

The curing times are extremely short. The times above apply to the IRT PcAuto series.

Add a minute or two for other models

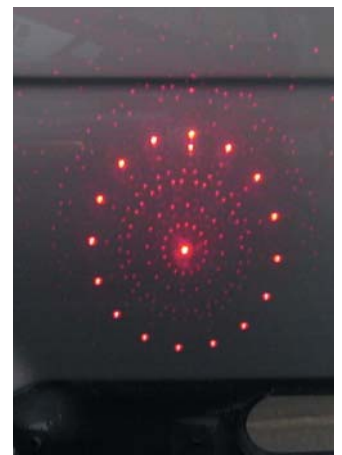

Built-in laser circle and distance sensor facilitates the settings.

Hyperion advantages

IRT 4-20 PcAuto
 IRT 4-2 PcAuto
 IRT 4-1 PcAuto
 IRT 3-20 PCD
 IRT 3-2 PCD
 IRT 3-1 PCD
 IRT 4 PrepCure
 IRT 3 PrepCure
 IRT 2 PrepCure
 IRT 1 PrepCure

Even heat distribution	X	X	X	X	X	X	X	X	X	X
Short curing times	X	X	X	X	X	X	X	X	X	X
Environmentally friendly, efficient use of energy	X	X	X	X	X	X	X	X	X	X
24 carat gold coated reflectors with 97% reflection	X	X	X	X	X	X	X	X	X	X
Powerful ventilation provides the lamps with a service life of up to 20,000 operating hours	X	X	X	X	X	X	X	X	X	
FreeForm reflectors for an unsurpassed drying surface	X	X	X	X	X	X	X	X	X	
Efficient particle filter that creates a dust-free environment in the cassettes	X	X	X	X	X	X	X	X		
Enclosed cassette cables	X	X	X	X	X	X	X	X		
The angle of the arm provides increased reach	X	X	X	X	X	X	X			
The stand is adapted also to dry high cars, e.g. SUVs	X	X	X	X	X	X	X			
The arm is self-locking in all positions	X	X	X	X	X	X	X			
Electronic distance sensor	X	X	X	X	X	X				
Self-instructive programs	X	X	X	X	X	X				
Computerised curing process	X	X	X	X	X	X				
12 program presets – 3 custom programs	X	X	X	X	X	X				
Programs for plastic/metal/ water/solvent	X	X	X	X	X	X				
18 languages	X	X	X	X	X	X				
Pyrometer for exact temperature control	X	X	X							
Clear display with graphics showing the exact progress of the curing process	X	X	X							
Computerised temperature monitoring of curing process	X	X	X							
Laser circle indicates where temperature measurement takes place	X	X	X							

IRT Systems is a registered trademark.

© Hedson Technologies AB 2010

We reserve the right to make changes in design and make reservations for any mistakes in writing.

Printed in Sweden • 2010-01 • 700902 rev. 1



Hedson Technologies AB

Hammarvägen 4
 SE-232 37 ARLÖV, Sweden
 Tel +46 (0) 40 534200
 Fax +46 (0) 40 432901

www.hedson.se

Bodyshop Solutions Ltd.

Unit 9 Stephenson Close
 Drayton Fields Ind. Est.
 Daventry, Northamptonshire
 NN11 8RF
 Tel: 01327 300700, Fax: 01327 300586
 E-mail: info@bodyshopsolutionsltd.com

