

Resistance spot welding



InvertaSpot GT
AUTOMATIC

OEM
Recommendations

ACCESSORIES

CONSUMABLES

Table of contents

INVERTASPOT GT AUTOMATIC	Page 3
VAS 6545A	Page 4
C-Trafogun GT-V6	Page 5
C-Arms	Page 6
Electrode sets C-Trafogun	Page 7
Electrodes	Page 9
X-Trafogun GT-V6	Page 10
Electrode sets X-Trafogun	Page 11
Electrode caps	Page 12
Airpuller AP95	Page 13
Spot welding gun PSP - GT	Page 14
Accessories PSP - GT	Page 15
Accessories for InvertaSpot GT AUTOMATIC	Page 17

Version	Voltage	Item no.
WS version	400 V	471002
WS version	200 V	473002
WS version CN	400 V	471007
VAS 6545A	400 V	932160
VAS 6545A	200 V	932131
VAS 6545A version UL	200 V	932163
VAS 6545A version CN	400 V	932167
BMW version	400 V	932331
BMW version	200 V	932332
BMW version Active Cooling	400 V	932333
BMW version CN	400 V	932338
Citroën version	400 V	471002
Citroën version	200 V	473002
Ferrari version	400 V	471025
Ford version	400 V	932710
Ford version	200 V	932711
GM version	400 V	471002
GM version	200 V	473002
Honda version	400 V	933710
Honda version	200 V	933711
Hyundai version	400 V	471002
Hyundai version	200 V	473002
Jaguar version	400 V	471002
Jaguar version	200 V	473002
Mazda version	400 V	471002
Mazda version	200 V	473002
Mercedes-Benz version	400 V	932436
Mercedes-Benz version	200 V	932437
Mercedes-Benz version CN	400 V	471023
Opel version	400 V	932182
Opel version	200 V	932183
Peugeot version	400 V	471002
Peugeot version	200 V	473002
Renault version	400 V	471002
Renault version	200 V	473002
Tesla version	400 V	960750
Tesla version	200 V	960753
Tesla version UL	200 V	471019
Tesla version CN	400 V	960752
Vauxhall version	400 V	932182
Vauxhall version	200 V	932183
Huk-Coburg version	400 V	471031
Innovation Group version	400 V	471030

The scope of delivery is different for all versions!

TESTED AND
RECOMMENDED BY

ACURA
BMW
BUICK
CADILLAC
CHEVROLET
CITROËN
DACIA
FERRARI
FORD
GM
GMC
HONDA
HYUNDAI
JAGUAR LAND ROVER
KIA
MAYBACH
MAZDA
MERCEDES-BENZ
MINI
OPEL
PEUGEOT
RENAULT
ROLLS-ROYCE
SMART
TESLA
VAUXHALL



Resistance spot welding machine

The InvertaSpot GT-C AUTOMATIC is suitable for high and ultra high strength steels. It detects the conditions at the joining point, sets parameters automatically and monitors the welding process. Due to the full automation, it is extremely energy-efficient. Experts can still use the manual mode if necessary and set the parameters freely.

InvertaSpot GT
A U T O M A T I C

InvertaSpot GT AUTOMATIC

Mains voltage

Item no. 471002

3 x 400 V

Item no. 473002

3 x 200-240 V

Detailed information on page 3-5

Scope of delivery:

1 x C-transformer gun 3 m

1 x C-arm N° 1

1 x Suspension unit with spring balancer

1 x 474250 Allen key (4+5 mm)

1 x 497096 Electrode caps type A-32

1 x 474028 Lateral hanger for C-arms

1 x 478085 Holder for cable package

1 x 478041 Suspension hook for power cable

1 x 474007 Wheel set incl. screws

1 x Instruction manual





**SAVING OF INDIVIDUAL
WELDING PARAMETERS**





**DOCUMENTING AND
MANAGING OF JOB
DATA**

**MATERIAL
RECOGNITION**

SOFTWARE UPDATES

**CURRENT CONTROL
AND PRESSURE
MONITORING**



-  **Energy-efficient**
-  **Time saving**
-  **Software updates**
-  **Best service**
-  **Local support**

Resistance spot welder

The VAS 6545A resistance spot welder can be used to carry out all approved repair welds on Volkswagen Group vehicles. The welding parameters are set using simple, self-explanatory symbols. The welding programmes are for high-strength and ultra high-strength sheet metal, for adhesive spot-welded joints and for galvanised sheet metal.

VAS 6545A

VAS 6545A	ASE Number	Mains voltage
Item no. 932160	ASE 437 075 01 000	3 x 400 V
Item no. 932161	ASE 437 075 00 023	3 x 200-240 V

Accessory set 7 pieces

VAS 6545A/1	ASE Nummer
Item no. 932110	ASE 437 075 01 000

Accessory set for the resistance spot welder VAS 6545A for device protection and for extending the application range of spot welding.

- Scope of delivery:
- 1 x Cover for InvertaSpot GT
 - 1 x Raising & wheel spacer set
 - 1 x Electrode set N° 7 for C-arm N° 1 cap size 16; 90°
 - 1 x C-arm N° 4 with electrode 260 mm; cap size 16
 - 1 x Electrode 170 mm, for C-arm N° 4 cap size 16
 - 1 x Electrode cap remover
 - 1 x Abrasive sponge grain 60



- Scope of delivery:
- 1 x Control unit with water tank 80 l
 - 1 x C-trafogun 3 m
 - 1 x C-arm N° 1
 - 1 x C-arm set N° 3 + E-set 90°
 - 1 x Suspension unit with spring balancer
 - 1 x Hanger for C-arms
 - 1 x Instruction manual





AUTOMATIC FUNCTION

PROCESS CONTROL

ELECTRONIC DISTANCE MEASUREMENT

WATER COOLING UP TO THE ELECTRODE CAPS

LARGE OPENING ANGLE

1-BUTTON OPERATION

The transformer gun was developed under strict EN standards and corresponds to the latest technological state of safety. The electrode lock with water stop when changing the arms provides additional safety and comfort. With the numerous electrode arms and the extensive range of accessories, no wishes are left unfulfilled - but special designs are also possible on request.

C-TRAFOGUN GT-V6

C-Trafogun GT-V6

Item no. 474466

Scope of delivery:

- 1 x C-trafogun 3 m
- 1 x C-arm N° 1
- 1 x Electrode caps I type A-32
- 1 x Suspension hook
- 1 x Rotation ring



Cable bundle length	L x W x H	Weight	Adjustment range	Welding current	Electrode pressure	Mark of conformity
Standard: 3 m up to 6 m possible	600 x 100 x 320 mm	15 kg	0-13 kVA	max. 13 kA	max. 6.2 N	CE/UL/CCC depending on version



C-Arm N° 1 | standard

Item no. 495620

Electrodes	Electrode caps
C-electrode curved	Ø 16 mm

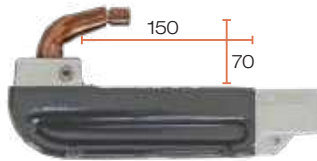

C-Arm N° 2 | for wheel arches

Item no. 495602

Electrodes	Electrode caps
Electrode A Mushroom shape Electrode B Spoon shape	Ø 13 mm

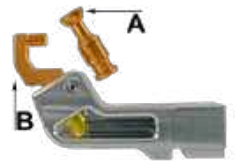

C-Arm N° 3

Item no. 495625

Electrodes	Electrode caps
C-Electrode curved	Ø 16 mm

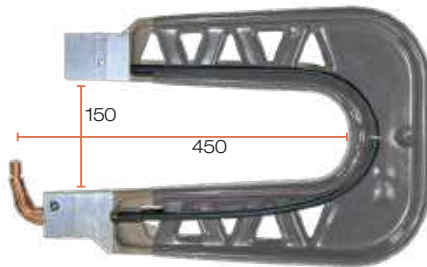

C-Arm N° 4

Item no. 495615

Electrodes	Electrode caps
Electrode 260 mm Electrode holder	Ø 16 mm

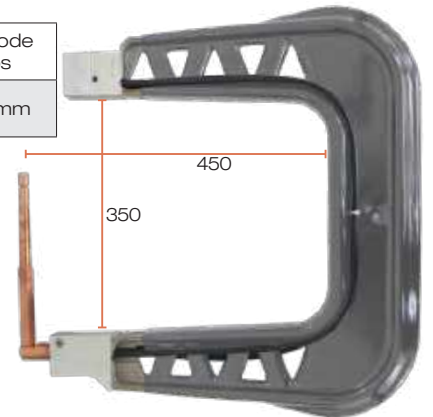

C-Arm N° 5

Item no. 495626

Electrodes	Electrode caps
C-Electrode curved Electrode 135 mm Copper sealing washer	Ø 16 mm

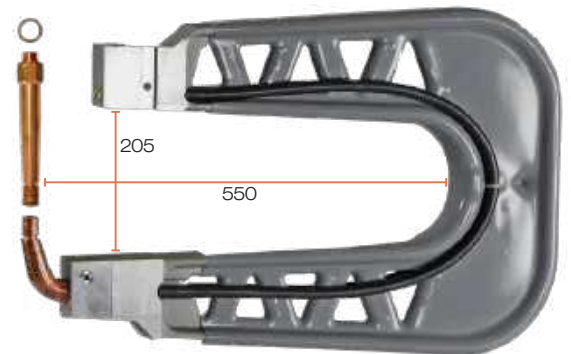

C-Arm N° 6

Item no. 495611

Electrodes	Electrode caps
Electrode 46 mm Electrode holder	Ø 16 mm

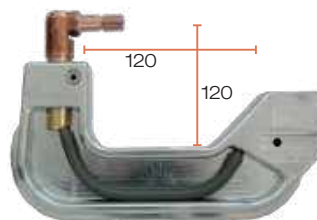

C-Arm N° 7

Item no. 495650

Electrodes	Electrode caps
Electrode 83 mm Electrode holder	Ø 16 mm

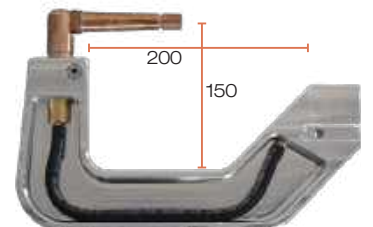

C-Arm Set | C-Arm N° 2 + N° 3

Item no. 495630

Electrodes	Electrode caps
C-Electrode curved Electrode A Mushroom shape Electrode B Spoon shape	Ø 16 mm

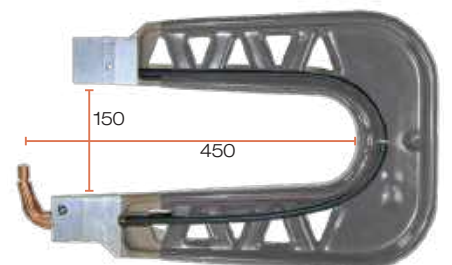
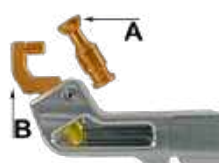

C-Arm Electrode attachment with rocker „Passat“

Item no. 495664

For C-arm N° 1

Electrode set with rocker for welding very narrow strips of sheet metal, e.g. on the VW Passat. Due to the concentric electrodes, which move the welding spot from the centre to the outside, you can reach every corner.

Full functionality of the automatic mode guaranteed.



Electrodes hexagonal

Item no. 495669

QTY: 2 pcs.



Electrodes concentric

Item no. 495679

QTY: 2 pcs.



C-Arm Electrode attachment with rocker N° 10 | for wheel arches

Item no. 495604

For C-arm N° 1

Electrode set with rocker for easier welding of wheel arches. For all repair/welding tasks where there is no accessibility with conventional electrodes.

Full functionality of the automatic mode guaranteed.



Electrode flat

Item no. 495659



Electrode F1 finger shape

Item no. 497073



Electrode Set N° 7 | 90° angle

Item no. 495607

For C-Arm N° 1

Electrodes	Electrode caps
Electrode 149 mm curved Electrode short curved Electrode holder	Ø 16 mm



Electrode 149 mm | curved

Item no. 495676



Electrode short | curved

Item no. 495695



Electrode Set N° 9 | 38° angle

Item no. 495645

For C-Arm N° 1

Electrodes	Electrode caps
Electrode bent 38° long Electrode bent 38° short Electrode holder	Ø 16 mm



Electrode Set N° 12 | 38° angle

Item no. 495646

For C-Arm N° 1

Electrodes	Electrode caps
Electrode bent 38° long Electrode bent 38° short	Ø 16 mm



Electrode bent 38° | long

Item no. 495677



Electrode holder for Set N° 7 & N° 9

Item no. 495627



Screw bolt for electrode set N°7

Item no. 495693



O-rings for screw bolt

Item no. 495694

QTY: 3 pcs.



Electrode Set N° 11 | 90° angle

Item no. 495606

For C-Arm N° 1

Electrodes	Electrode caps
Electrode 121 mm Electrode 28 mm	Ø 16 mm



Electrode 28 mm

Item no. 495623











Electrode 121 mm

Item no. 495622



Electrodes

Length	Shape	suitable for C-Arm							Item no.
		N° 1	N° 2	N° 3	N° 4	N° 5	N° 6	N° 7	
46 mm	straight 						●		495621
83 mm	straight Standard electrode on gun side 				●			●	495617
135	straight 					●			495667
170	straight 				●				495619
260	straight 				●				495616
	c-shape curved 	●		●		●			495635
	Shape A Mushroom 		●						497070
	Shape B Spoon 		●						497072

Electrode Set for C-Arm N° 4

Item no. 495618

QTY: 2 pcs.



Electrode holder

Item no. 495692

suitable for:

- C-Arm N° 4
- C-Arm N° 6
- C-Arm N° 7



Copper sealing washers M16

Item no. 494040

QTY: 2 pcs.



**HIGH ACCESSIBILITY IN
NARROW PLACES**

**PARTICULARLY LIGHT
AND EASY TO HANDLE**

**WATER COOLING UP TO
THE ELECTRODE CAPS**

1-BUTTON OPERATION



X-TRAFOGUN GT-V6

The transformer gun was developed under strict EN standards and corresponds to the latest technological state of safety. With the numerous electrode arms and the extensive range of accessories, no wishes are left unfulfilled - but special designs are also possible on request.

X-Trafogun GT-V6

Item no. 474402

Scope of delivery:
1 x X-Trafogun 3 m
1 x Electrode Set N° 69
1 x Suspension bracket
1 x Integrated vertical suspension plate



Cable bundle length	L x W x H	Weight	Adjustment range	Welding current	Electrode pressure	Mark of conformity
Standard: 3 m up to 6 m possible	600 x 100 x 320 mm	15 kg	0-13 kVA	max. 13 kA	max. 6.2 N	CE/UL/CCC depending on version

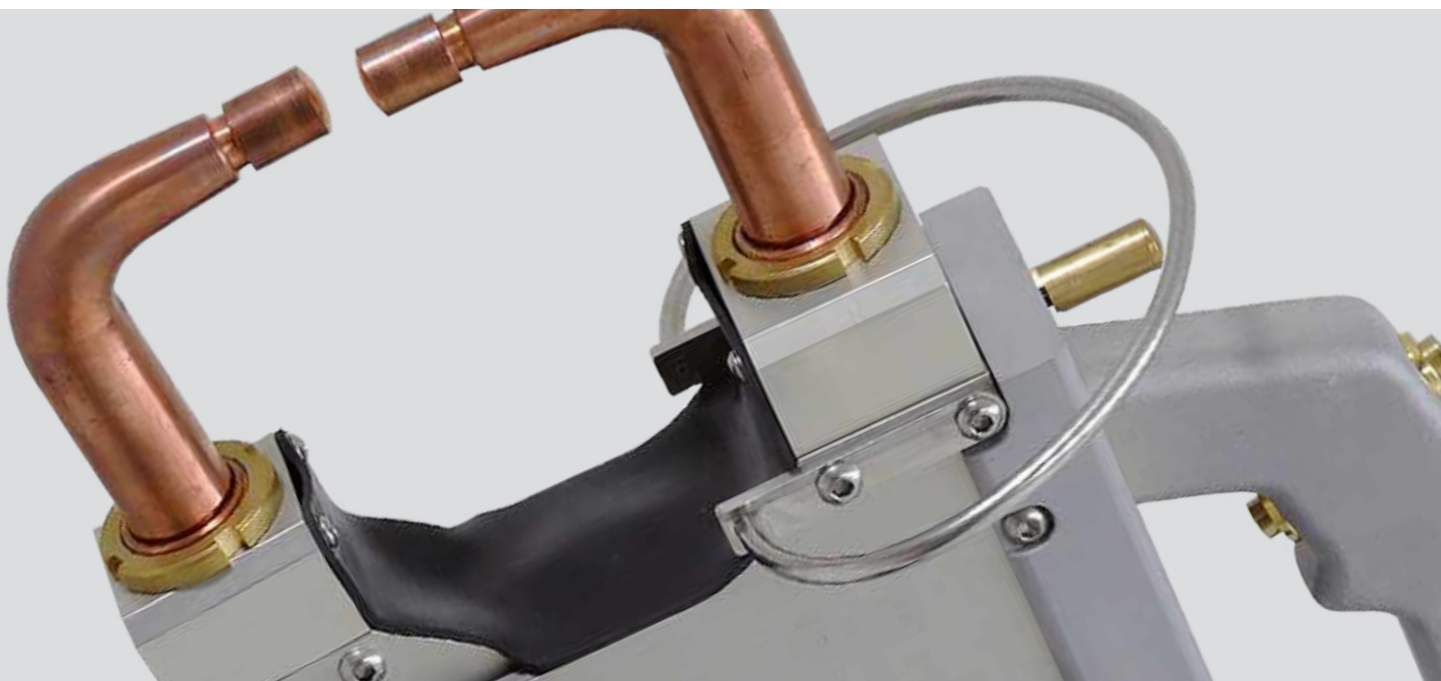

Electrode Set N° 50 | straight 90°

Item no. 495715

Diameter	Length
16 mm	280 mm



Electrode Set N° 51 | straight 90°

Item no. 495750

Diameter	Length
16 mm	420 mm



Electrode Set N° 59 | cranked

Item no. 495740

Diameter	Length
16 mm	280 mm



Electrode Set N° 65

Item no. 495800

Diameter	Length
16 mm	280 mm



Electrode Set N° 66 | standard

Item no. 495805

Diameter	Length
16 mm	260 mm



Electrode Set N° 67 | pointed shape

Item no. 495815

Diameter	Length
16 mm	260 mm



Electrode Set N° 68 | for wheel arches

Item no. 495065

Not water cooled



Angle Electrode | E-set N° 68

Item no. 497040



Electrode Isotube | E-set N° 68

Item no. 497041

Diameter
14 mm



Electrode Set N° 69 | standard

Item no. 495820

Diameter	Length
16 mm	120 mm



Electrode Set N° 72 | Sprinter | Astra

Item no. 495082

Diameter	Length
13 mm	120 mm



Electrode caps | E-set N° 72 | round

Item no. 497086 QTY: 3 psc.



Electrode Caps

Ø 13 mm

Type	F round	Spade shape long	A R32	straight	straight	sloped R20	E	D
Length	18 mm	23 mm	18 mm	19,5 mm	24 mm	16,5 mm	18 mm	18 mm
Suitable for					X-gun E-Set no. 74	X-gun E-Set no. 70		
QTY	6 pcs.	6 pcs.	6 pcs.	6 pcs.	6 pcs.	6 pcs.	4 pcs.	4 pcs.
Item no.	497001	497004	497005	497006	497007	497008	497016	497018



Type	Ø 12 mm ball	Ø 12 mm sloped		round	short		
Length	18 mm	18 mm		18,5 mm	16 mm		
Suitable for	Multi Spot I 297106	Multi Spot		X-gun E-Set no. 72	X-gun E-Set no. 73		
QTY	6 pcs.	6 pcs.		3 pcs.	3 pcs.		
Item no.	297121	297122		497086	497009		



Ø 16 mm

Type	A-32	B conical-flat	H Spade shape	E	A-40 R 40	D conical-flat	F round	P eccentric	D 38°
Length	20 mm	20 mm		20 mm	20 mm		20 mm	20 mm	24 mm
Suitable for	C-Trafogun AUTOMATIC		Warning! X-gun only						E-Set no. 9 (495645) E-Set no. 12 (495646)
QTY	6 pcs.	4 pcs.	6 pcs.	4 pcs.	6 pcs.	4 pcs.	4 pcs.	4 pcs.	6 pcs.
Item no.	497096	497079	497020	497081	497097	497085	497075	497076	497105



Electrode Cap Set

Item no. 497102

Scope of delivery:
 2 x Electrode cap type B (497079)
 2 x electrode cap type H (497020)



Electrode caps assortment | Ø 16 mm | C-Trafogun

Item no. 497110

Scope of delivery:
 1 x Assortment box
 2 x Electrode cap type A-40
 4 x Electrode cap type B
 2 x Electrode cap type E
 2 x Electrode cap type A-32
 2 x Electrode cap type H
 2 x Electrode cap type D
 2 x Electrode cap type P





PULLING IN SHEET METAL

BULGING

ESPECIALLY SUITABLE FOR

- HAIL DAMAGE
- SMALL DENTS
- SCRATCHES & STRIPES
- DOUBLE-WALLED SPOTS

HIGH EFFICIENCY

UNRIVALLED IN HANDLING, TIME AND COST SAVINGS

With the Airpuller AP95, dent removal work can be done from the outside in a fraction of the time previously required. Longitudinal scratches, streaks on the side panels or doors can be easily and quickly repaired with the AP95. The well-known hail damage on car roofs can be repaired without any problems.

Airpuller AP95

Airpuller AP95-GT for C-Gun

Item no. 351002

Scope of delivery:
1 x Airpuller AP95
1 x Ground cable

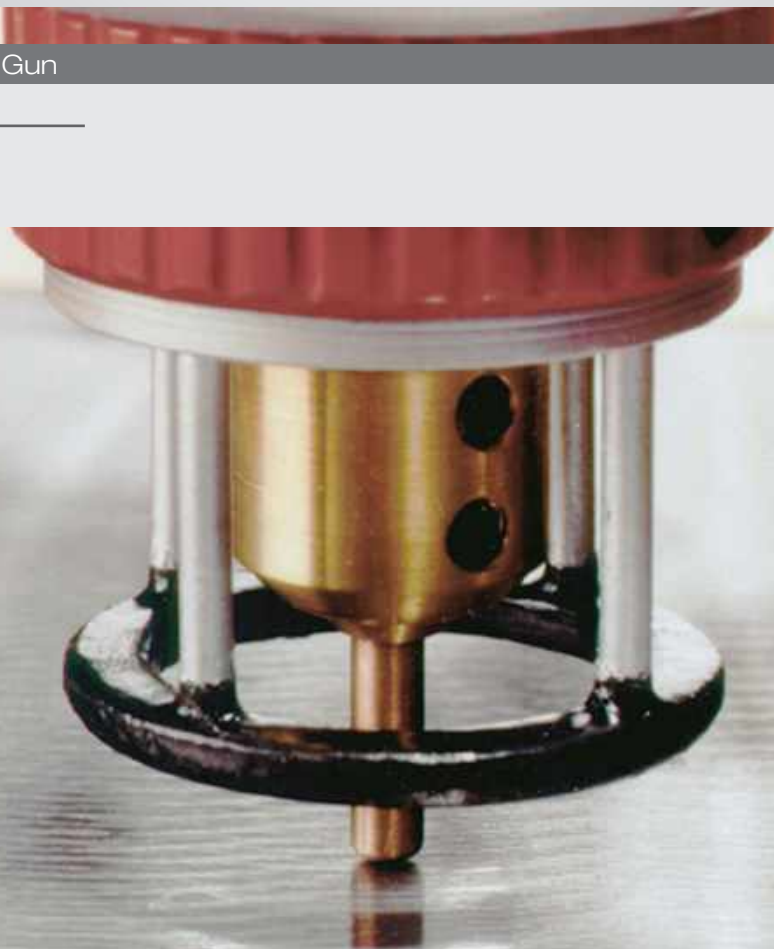

**HIGH ACCESSIBILITY IN
NARROW PLACES**

**PARTICULARLY LIGHT
AND EASY TO HANDLE**

**WATER COOLED
DOWN TO THE
ELECTRODE CAPS**

1-BUTTON OPERATION



SPOT WELDING GUN PSP - GT

A multifunctional gun for many applications.

By changing the contact pieces, it is possible to attach different bits to the bodywork, matching the type of dent removal method that follows.

Spot welding gun GT - 2.5 m

Item no. 478006

Scope of delivery:

1 x Spot welding gun with SK22

1 x Ground cable with D25

1 x Assortment box (478002)

consists of:

1 x 490007 electrode cap holder incl. cap

1 x 497014 contact piece for wiggle wire

1 x 497015 contact piece for washers

1 x 297009 washers (100 pcs.)

1 x 497016 electrode caps 4 pcs. I type E | Ø 13 mm



water-cooled

Spot welding gun GT - 2.5 m

Item no. 478001

GT vicegrip with mounting SK-22 PSP

Item no. 475012



GT vicegrip with mounting D-25 | Ground cable

Item no. 475013



Quick dent pulling hammer | Set

Item no. 478100

Scope of delivery:

- 1 x Quick dent pulling hammer GT (M14)
- 1 x Contact piece for Triangle pulling ring washers (M14)
- 1 x Hook for washers
- 1 x Washers (100 pcs.)
- 5 x Triangle pulling ring washers



Quick dent pulling hammer M14

Item no. 501025

Note:

Suitable for the InvertaSpot GT and the spot welding gun PSP60 (351070)

Scope of delivery:

- 1 x Quick dent pulling hammer GT



Contact piece for Triangle pulling ring washers

Item no.	501031	501033
Thread	M10	M14
QTY /	1 pc. /	1 pc. /



Hook for washers

Item no.	501034
Thread	M14
QTY /	1 pc. /



Contact pieces for spot welding gun PSP

Item no.	497014	497015	497019	497021	497023	497017
Application	Wiggle wire	Washers	T-pins	Studs 2-2.5 + 4 mm	Studs 5 + 6 mm	Upsetting metal
QTY /	1 pc. /	1 pc. /	1 pc. /	1 pc. /	1 pc. /	1 pc. /



Carbon electrode for spot welding gun PSP

Item no. 297107

Diameter: 9.5 mm
Length: 305 mm



Carbon electrode for spot welding gun PSP

Item no. 497026

Diameter: 12 mm
Length: 150 mm



Electrode for spot welding gun PSP

Item no. 297106

Diameter: 12 mm
Length: 98.5 mm



Consumables

Item no.	297013	297009	497028	497025
Item	Triangle pulling ring washers	Washers DIN 125	Washers copper-plated	Weld-on nut M8 copper-plated
VPE	15 pcs.	100 pcs.	100 pcs.	25 pcs.



Weld-on studs | coarse thread

Item no.	297055	297052	297053	297054
Dimensions	5.0 x 9.0 mm	5.0 x 14.2 mm	5.0 x 18 mm	5.0 x 25 mm
Material	Steel 4.8 copper-plated	Steel 4.8 copper-plated	Steel 4.8 copper-plated	Steel 4.8 copper-plated
VPE	15 pcs.	50 pcs.	100 pcs.	25 pcs.



Weld-on pins

Item no.	297031	297032	297033
Item	T-pins 3 x 3.2 mm	T-pins „VW“ 3 x 4.5 mm	T-pins 5 x 10 mm
VPE	100 pcs.	100 pcs.	50 pcs.



Weld-on studs | metric thread

Item no.	497027	297061	297062
Dimensions	M4 x 15 mm	M6 x 12 mm	M6 x 20 mm
Material	Steel 4.8 copper-plated	Steel 4.8 copper-plated	Steel 4.8 copper-plated
VPE	50 pcs.	50 pcs.	50 pcs.



Wiggle wire

Item no.	507030	507031
VPE	10 pcs.	50 pcs.



Cover

Item no. 478005

To protect the high-quality spot welding unit from dust, dirt, water.
With Velcro fastener on the side.



Track extension set GT

Item no. 932103

Back-friendly work, relief of arms and shoulders:
When vehicles stand on a straightening bench, some of them are hard to reach. The user would like to extend the balancer tube upwards. This means that the C-Gun hangs higher overall.

The Track extension set

- extends the straight balancer tube
- widens the wheelbase of the spot-welding unit
- effectively prevents the system from tipping sideways
- provides safety and protection

Scope of delivery:

- 1 x Balancer tube 630 mm
- 1 x Insulating webbing 650 mm
- 2x Plate left + right
- 1 x Screw set | 32 pieces



Anticorrosive concentrate WT1000 - 150 ml

Item no. 470008

Suitable for all welding equipment, especially spot welding systems.
Protects sensitive surfaces from corrosion caused by operation with cooling water.
Protects in particular all electronic components, copper cables and copper electrodes from so-called „contact corrosion“.

Mixing ratio 150 ml for 80 litres of coolant.



Item no.	478060	474017	478010	474085
Item	Balancer roller white aluminium	Insulating webbing	Handle extension set for Trafogun 58 mm	Cable bundle holder
VPE	1 pc.	1 pc.	1 pc.	1 pc.



Electrode cap remover

Item no. 498003



Electrode fix | grain 60

Item no. 298298

For cleaning spot welding electrode caps when dirty- Only „clean“ electrode caps guarantee correct spot welding results.



EUROPAX Welding primer - 500 ml

Item no. 817030

Prevents rust and oxidation between sheets for spot welding as well as MIG-MAG.



Electrode copper paste - 75 g

Item no. 497010

- Measurably reduces contact resistances
- Improves the current conduction properties of electrode arms



Welding strips V2A

Item no. 297300

- Stainless steel welding strips
- Used for spot welding of thin aluminium sheets.
- For the outer layer to increase the welding resistance.





<https://www.wielanderschill.com/agb>

Lieferung ab Werk. Alle Preise zzgl. MwSt. Es gelten unsere AGB.
Druckfehler, Irrtümer und Änderungen vorbehalten.
Misprints, mistakes and alterations are reserved.

WS Wieländer+Schill GmbH & Co. KG
Professionelle Karosserie-Spezialwerkzeuge
Neue Wiesen 8
D-78609 Tuningen

Kontakt / Contact

Tel. +49 (0)7464 9898 0
Fax +49 (0)7464 9898 289

info@wielanderschill.com