



INSTRUCTIONS FOR
TYRE CHANGER - AUTOMATIC
 MODEL NO: **TC10**

Thank you for purchasing a Sealey product. Manufactured to a high standard, this product will, if used according to these instructions, and properly maintained, give you years of trouble free performance.

IMPORTANT: PLEASE READ THESE INSTRUCTIONS CAREFULLY. NOTE THE SAFE OPERATIONAL REQUIREMENTS, WARNINGS & CAUTIONS. USE THE PRODUCT CORRECTLY AND WITH CARE FOR THE PURPOSE FOR WHICH IT IS INTENDED. FAILURE TO DO SO MAY CAUSE DAMAGE AND/OR PERSONAL INJURY AND WILL INVALIDATE THE WARRANTY. KEEP THESE INSTRUCTIONS SAFE FOR FUTURE USE.



Refer to instructions



Wear eye protection



Wear protective gloves



Wear safety footwear



Wear protective clothing



Wear ear protection



Electrical shock hazard



Crushing of hands hazard

1. WARNING LABEL LOCATIONS



When clamping the rim, **DO NOT** place hand or any other part of the body between the clamping jaw and the wheel rim.



DO NOT stand behind the column



DO NOT put any body part under the tool head



WARNING! Electricity



When bead breaking the blade moves very quickly to the left. The operator should not stand between the blade and the tyre

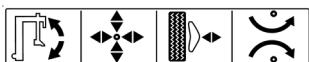

2. SAFETY

2.1. ELECTRICAL SAFETY

- ❑ **WARNING!** It is the user's responsibility to check the following:
Check all electrical equipment and appliances to ensure that they are safe before using. Inspect power supply leads, plugs and all electrical connections for wear and damage. Sealey recommend that an RCD (Residual Current Device) is used with all electrical products. You may obtain an RCD by contacting your local Sealey dealer.
If the product is used in the course of business duties, it must be maintained in a safe condition and routinely PAT (Portable Appliance Test) tested.
Electrical safety information, it is important that the following information is read and understood.
- 2.1.1. Ensure that the insulation on all cables and on the appliance is safe before connecting it to the power supply.
- 2.1.2. Regularly inspect power supply cables and plugs for wear or damage and check all connections to ensure that they are secure.
- 2.1.3. **Important:** Ensure that the voltage rating on the appliance suits the power supply to be used and that the plug is fitted with the correct fuse - see fuse rating in these instructions.
 - ✗ **DO NOT** pull or carry the appliance by the power cable.
 - ✗ **DO NOT** pull the plug from the socket by the cable.
 - ✗ **DO NOT** use worn or damaged cables, plugs or connectors. Ensure that any faulty item is repaired or is replaced immediately by a qualified electrician.
- 2.1.4. This product is fitted with a BS1363/A 13 Amp 3 pin plug.
If the cable or plug is damaged during use, switch off the electricity supply and remove from use.
Ensure that repairs are carried out by a qualified electrician.
Replace a damaged plug with a BS1363/A 13 Amp 3 pin plug. If in doubt contact a qualified electrician.
 - a) Connect the GREEN/YELLOW earth wire to the earth terminal 'E'.
 - b) Connect the BROWN live wire to the live terminal 'L'.
 - c) Connect the BLUE neutral wire to the neutral terminal 'N'.Ensure that the cable outer sheath extends inside the cable restraint and that the restraint is tight.
Sealey recommend that repairs are carried out by a qualified electrician.

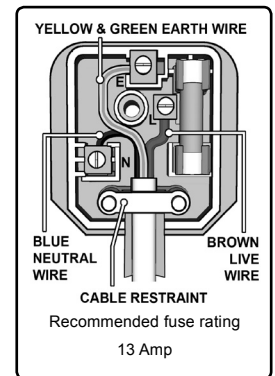

2.2. GENERAL SAFETY

- ❑ **WARNING!** Ensure that Health & Safety, Local Authority Regulations and general workshop practice Regulations are adhered to when using Tyre changer. Read and fully understand instructions and safety labels attached to machine.
- ✓ Wear appropriate Personal Protective Equipment. A full range of Personal Protective Equipment is available from your Sealey stockist.
- ✓ Wear suitable clothing to avoid snagging. **DO NOT** wear jewellery. Tie back long hair.
- ✓ Maintain machine to ensure it is in an adequate condition for safe use and optimum performance.
- ✗ **DO NOT** use Tyre changer if damaged.
- ✓ This machine should only be operated by trained personnel.
- ✓ This machine should only be used for the purpose for which it is intended and not modified in any way.
- ✓ The tyre changer must only be operated with specified voltage and air pressure.
- ❑ **WARNING!** The warnings, cautions and instructions in this manual cannot cover all possible conditions and situations. The Operator/user must apply caution and common sense.

2.3. WARNINGS AND PRECAUTIONS

- ✓ Make sure Tyre Changer is fitted/used on a dry, flat, level, oil/grease free, concrete surface capable of supporting the weight of the Tyre Changer.
- ✓ Before each use, always examine the Tyre Changer for structural cracks/defects, damage to the clamping jaws and electrical wiring, and any other condition that may affect the safe operation of the machine.
- ✗ **DO NOT** use the Tyre Changer if any defects are found.
- ✓ Maintain a safe working environment. Keep the work area well lit. Make sure there is adequate surrounding workspace. Always keep the work area free of obstructions, grease, oil and other debris.
- ✗ **DO NOT** use the Tyre Changer in a damp or wet location.
- ✗ **DO NOT** use the Tyre Changer in areas near flammable chemicals, dusts and vapours.
- ✓ This Tyre Changer is designed for use with most passenger cars and light commercial wheels.
- ✗ **DO NOT** attempt to exceed this machine's maximum wheel diameter of 24".
- ✓ Always keep hands, fingers, and feet away from the moving parts of the Tyre Changer while machine is in use.
- ✓ Always turn OFF mains power when not in use.
- ✓ Before using the machine, make sure tools and all other equipment is removed from the immediately vicinity.
- ✗ **DO NOT** use with an extension cable. Tyre Changer needs to be mounted near a suitable plug socket.
- ✓ Always unplug the Tyre Changer from its electrical supply before performing any inspection, maintenance, or cleaning procedures.
- ❑ **WARNING:** People with pacemakers should consult their physician(s) before using this product. Operation of electrical equipment in close proximity to a heart pacemaker could cause interference or failure of the pacemaker.

2.4. UNPACKING

When unpacking, check to make sure all parts shown on the Packing Lists are included. If any parts are missing or broken, please call your Sealey distributor.

3. INTRODUCTION

Automatic tyre changer capable of changing 11" to 24" wheel rims. Suitable for most cars and light commercial vehicles. Air operated rear tilting column and head lock. Protects alloy wheels with the added feature of plastic protectors, fitted to the clamping jaws and mounting head. Supplied with 485mm tyre lever, integrated tyre inflater, tyre soap tub, air regulator and lubricator. Model No.TC10A Assist Arm is required for use with low profile and run flat tyres. See Sealey website for demonstration video.

4. SPECIFICATION

Model No.....	TC10
Wheel Ø Min/Max.....	Internal Clamping 11"-20"External Clamping 12"-24"
Wheel Depth Min/Max.....	12" (305mm)
Turntable Ø.....	26" (660mm)
Bead breaking Force.....	2500kg
Tyre Inflater.....	0-10bar (0-145psi)
Voltage/Phase.....	230V - 1ph
Motor.....	1.1KW
Operating Pressure.....	8-10bar (115-145psi)
Inlet Size.....	1/4"BSP
Dimensions (W x D x H).....	690 x 1100 x1900mm
Weight.....	246kg
Optional Additional Tool.....	TC10A Assist Arm

5. POSITIONING AND ASSEMBLY

5.1. **The minimum required space around the machine is shown in fig. 1. It should be bolted to a flat/level surface using appropriate fixings as follows:**

5.2. INSTALLATION

5.2.1. Locating The Tyre Changer:

5.2.1.1. Make sure Tyre Changer is fitted/used on a dry, flat, level, oil/grease free, concrete surface capable of supporting the weight of the Tyre Changer.

5.2.1.2. The Tyre Changer is designed for indoors use only.

* **DO NOT** install or use the Tyre Changer outdoors, or in damp or wet locations.

5.2.1.3. Make sure to check the desired location for possible obstructions such as a low ceiling, adequate working area, access ways, exits. The Tyre Changer should be located in an area free of flammable materials and liquids.

5.2.1.4. Make sure the Tyre Changer is located near enough to a plug socket so it can be plugged into directly without the use of an extension cable.

5.2.2. Mounting The Tyre Changer To The Floor

5.2.2.1. With assistance, and with the use of a lifting device, position in the desired location. Use the four, 13mm (1/2") machine mounting holes located at the base of the Body as a template to mark the points where four floor anchor holes will be drilled in the floor surface. Then, temporarily remove the Tyre Changer.

5.2.2.2. Where previously marked on the concrete floor surface, drill four 13mm (1/2") diameter, minimum 100mm deep, anchor holes. NOTE: Be sure to blow out the cement dust from the drilled hole.

5.2.2.3. Move the Tyre Changer back to the desired location, and align the four machine mounting holes at the base of the Body with the four previously drilled floor anchor holes. If necessary, level the Tyre Changer by inserting steel shims between the base of the machine and the concrete floor surface. **DO NOT** exceed more than 5mm thickness of shims.

5.2.2.4. Secure the Tyre Changer to the concrete floor surface, using four 13mm (1/2") diameter concrete anchor bolts of appropriate length, four washers, and four nuts (not provided).

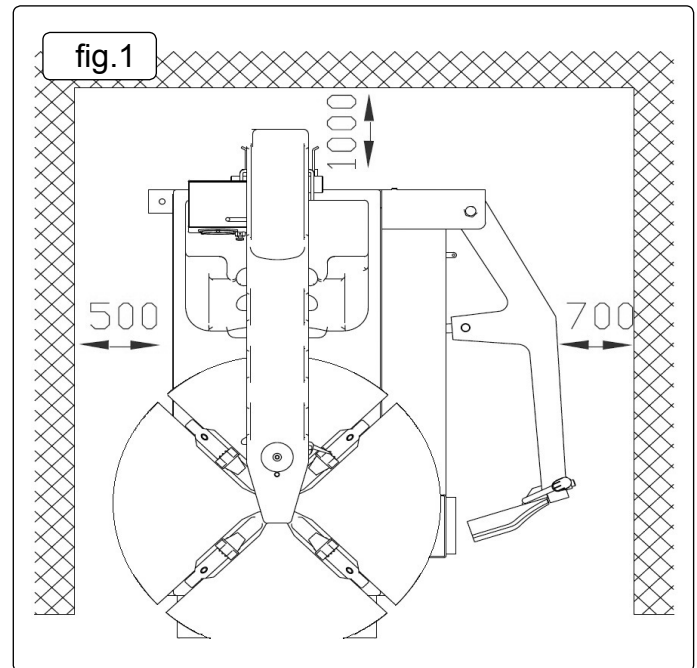

- 1. Vertical shaft spring
- 2. Handle valve
- 3. Hexagon shaft
- 4. Mounting/demounting head
- 5. Jaw
- 6. Turntable
- 7. Pedal label.
- 8. Column tilt pedal
- 9. Clamp pedal
- 10. Tyre bead braking pedal
- 11. Turn table pedal
- 12. Horizontal arm
- 13. Clamp turntable cylinder
- 14. Column
- 15. Blade handle
- 16. Bead breaking cylinder
- 17. Bead breaking arm
- 18. Bead breaking blade

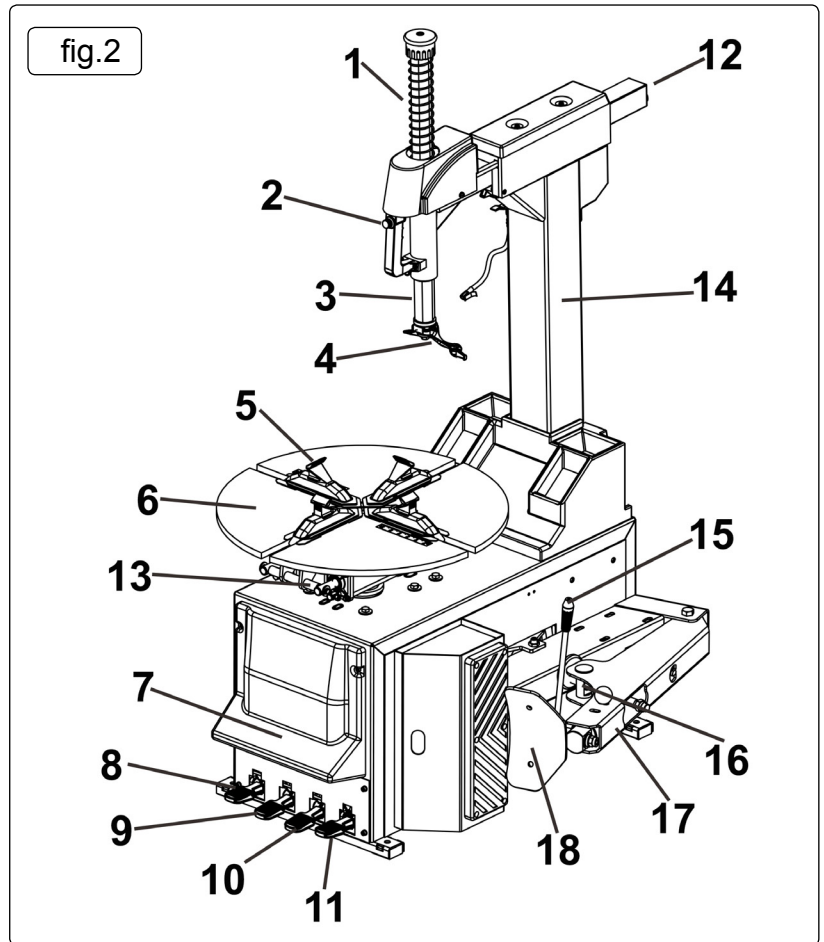

5.3. Column Installation.

5.3.1. According to the requirements shown in fig.1, position the main body of the machine. Unpack the accessory box and take out the rotation shaft assembly fig.3.1, and push out shaft assembly fig.3.2. Clean the assembly and lubricate with oil.

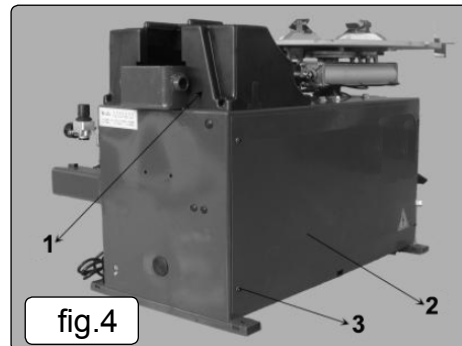

5.3.2. Remove the fixing screw fig.4.1, remove the side panel fig.4.2.

5.3.3. Remove the fixing screw fig.4.3, remove the tool box.

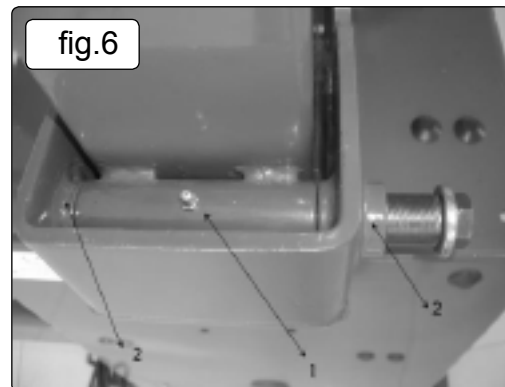
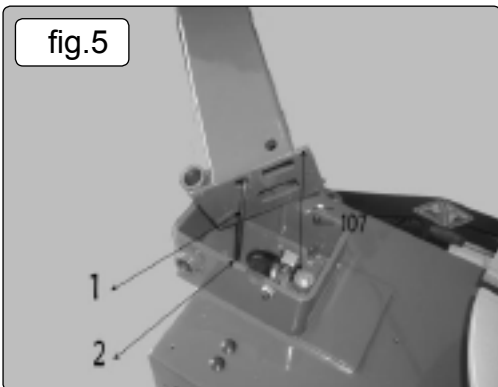

5.3.4. Lift up the column (two man lift) and insert the PU hose fig.5.1. at the bottom into the hole fig 5.2. on the top of the body. Adjust the position of the column to make the rotation shaft bushing fig.6.1 align with bearings fig.6.2. Remove the nut and washer at the one end of the rotational shaft assembly fig.3.1. Push the shaft through the bushes and fit the washer and tighten nut to a torque of 70Nm.

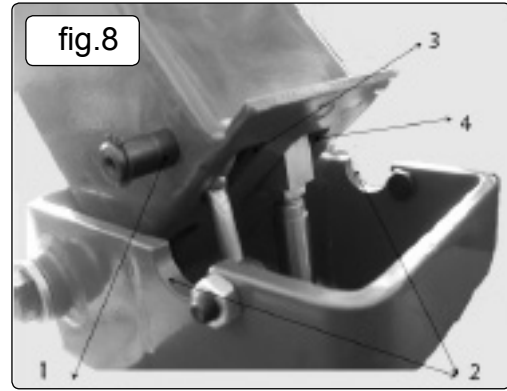
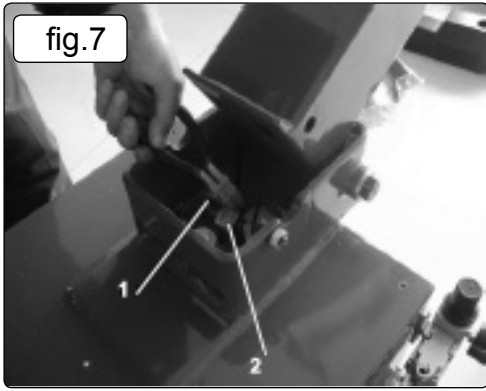

- 5.3.5. Tilt back the column and cut off the tie on the fixed shaft fig.7.1 and pull out the piston rod.
 5.3.6. Position the column as shown in fig.8. Remove the circlip from one end of the shaft fig.3.2 and pass the shaft through the 16mm hole, vertical retaining bar fig.8.3, piston rod fig.8.4 and through the hole on the opposite side of the column. Attach circlip to shaft.

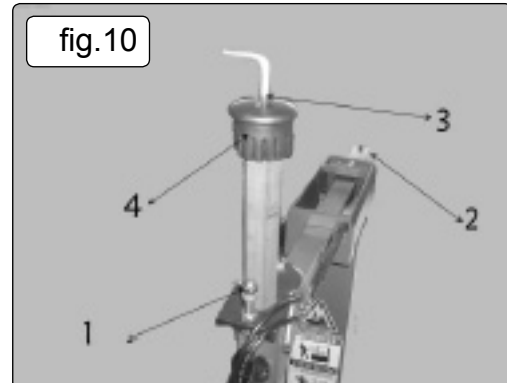

- 5.3.7. To install the horizontal arm protective cover, remove the cap nut fig.10.1, the screw at the back end fig.10.2 and the screw fig.10.3 at the top end of the vertical cap fig.10.4. Remove cap fig.10.4.
 WARNING! when detaching the vertical shaft cap, support the vertical shaft to prevent the vertical shaft from falling.
 5.3.8. Remove packaging from protective cover. Position as shown in fig.11.
 5.3.9. Twist on the cap nut fig.11.2 and screw fig.11.3. Install the vertical shaft spring fig.11.4, cap fig.10.4 and screw fig.10.3.

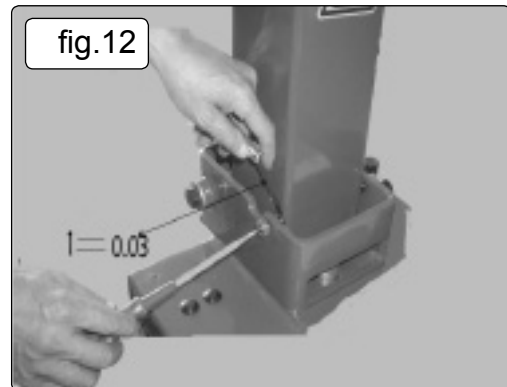
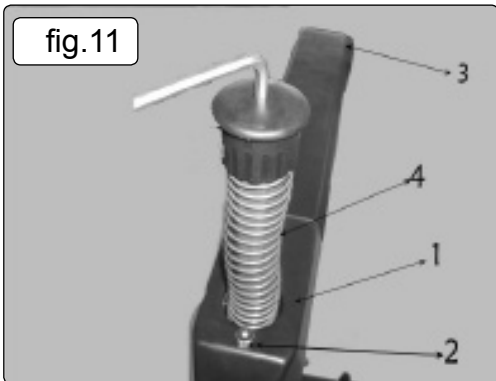

- 5.3.10. Adjust the column positioning screws on the two sides of the column. Release the nuts on the two sides and adjust the gap between the head of the screw and the side of the column to 0.03mm fig.12. and then lock the nut.
 5.3.11. Connect the air source, use the lock air valve push button to lock the horizontal arm fig.2.2. Operate the column tilt pedal fig.2.8 and the column will tilt backwards by about 25°. The speed of the movement of the column has been set to be about 2 seconds per stroke. After a time in operation, the speed may increase or decrease, you can use the speed adjusting valve to adjust the speed. To do this loosen the nut and turn the screw, turn the screw clockwise to decrease and counter-clockwise to increase. After adjustment, tighten the nut.
 5.3.12. Fix the side panel and tool box removed in step 4.2.2.
 5.4. **Compressed Air Installation**
 5.4.1. The compressed air regulator assembly can be found in the accessory box.
 5.4.2. Use the screw provided to fix the assembly on the right hand side (viewed from the back) of the body fig.13.

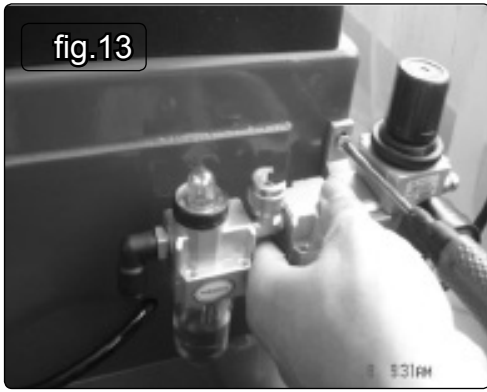

- 5.4.3. To connect the air hose, detach the adapter of the Ø8 PU hose on the side of the body. This adapter has the function to prevent the hose from sliding into the body. Insert the adapter into the elbow. See the fig.14 and fig.15.

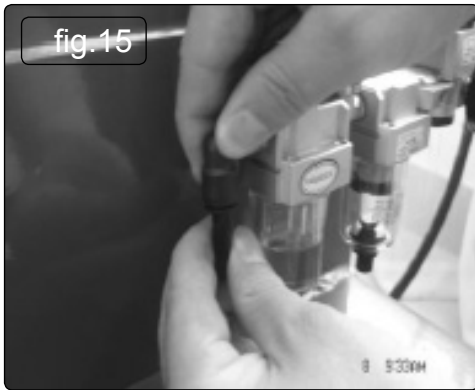

- 5.4.4. Connect the inflation gun fig.16. Then connect the air source.
 5.4.5. The air regulator has been adjusted before leaving the factory. If it needs adjusting, the air pressure can be adjusted by lifting the button fig.17.1 and turning clockwise to increase and anti-clockwise to decrease. To adjust the oil feed use a screw driver to turn screw fig.17.2, clockwise to decrease flow, anti-clockwise increase flow.

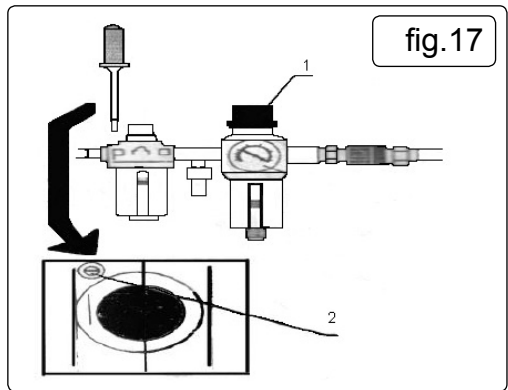

6. DEMOUNT AND MOUNT TYRE

6.1. Demount Tyre

- 6.1.1. Deflate the air in the tyre completely and remove the valve. Use a special tool to detach any weights on the rim, fig.18.

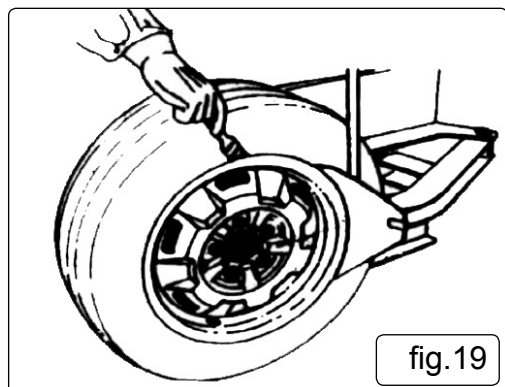
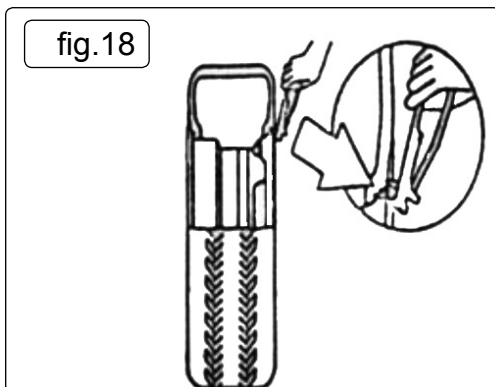

- 6.1.2. Place the tyre between the bead breaking blade and rubber tyre block. Position the bead breaking blade beside the lateral side of the tyre fig.19. Then operate the pedal to detach the rim from the tyre fig.2.10.

- 6.1.3. Repeat the operation on around the circumference of the tyre to make the tyre completely detached from the rim. Use the brush to spread lubricant or thick soap liquid between the lip and rim. Place the wheel with the tyre detached from the rim on the turntable and operate the clamp pedal fig.2.9 to clamp the rim. Select the outer clamp fig.20 or the inner clamp fig.21 to clamp the wheel according to different rim designs.

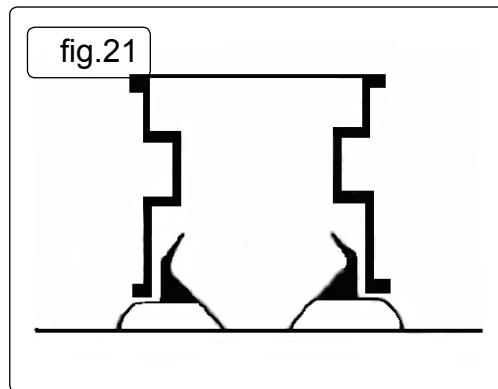
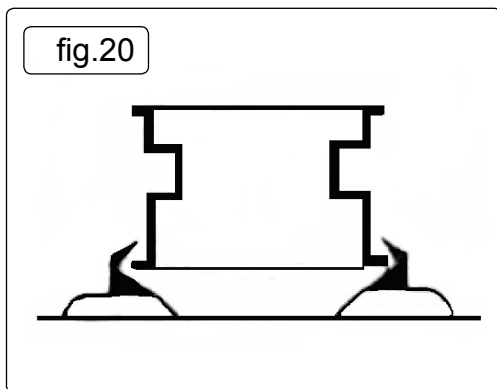

- 6.1.4. Move the hexagonal shaft to the working position making contact with the rim of the wheel. Press the lock handle button fig.2.2 to lock horizontal arm. The hexagonal shaft will automatically move upwards and backwards a few millimetres so there is not contact between the demounting head and the wheel rim avoiding damage. fig.22.

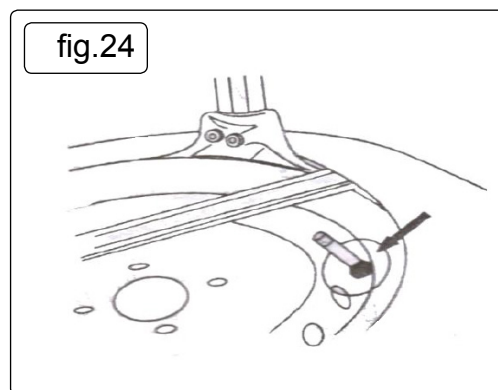
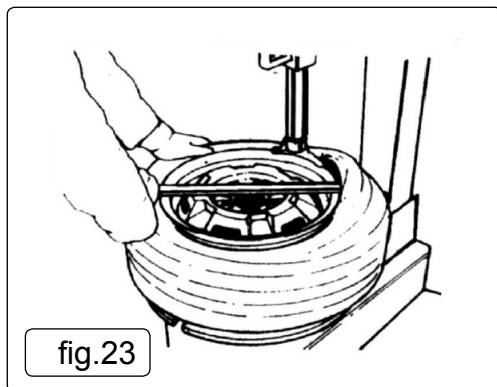
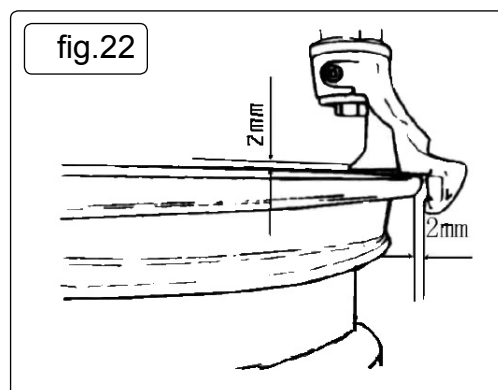

- 6.1.5. Use the tyre lever to lift the lip over the hump of the demounting head, fig.23. Operate the turntable rotation pedal fig.2.11 to rotate the turntable clockwise until the rim of the wheel is fully released. If handling a tyre with an inner tube, to avoid damaging the tube, you should keep the valve of the tyre 10cm from the right side of the demounting head fig.24.

- 6.1.6. If the tyre is jammed, stop the machine immediately, lift up the pedal to let the turntable rotate counterclockwise to remove the resistance.

- 6.1.7. Take out the inner tube(if required) and then move up the lower lip of the tyre so it contacts with the upper edge of the rim and repeat step 5.1.6. Detach the other lip fig.25. Operate the column tilt pedal fig.2.8 and the column will tilt backwards allowing removal of the tyre.

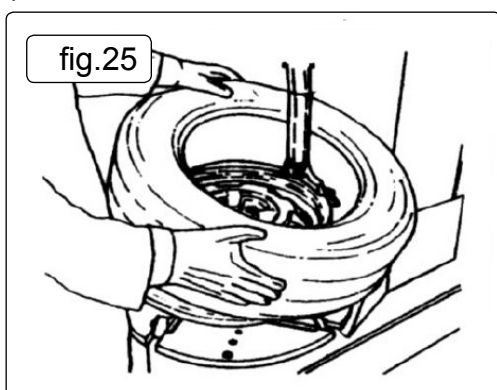

6.2. Mounting the Tyre

- ✓ Before mounting the tyre, check that the rim and tyre have the same dimension.
- 6.2.1. Clean up any oil or rust from the rim, select the inner or outer clamp, then lock the rim on the turntable.
- 6.2.2. Spread the lubrication liquid or soap liquid around the lip of the tyre. Tilt the tyre against the rim and keep the front end upwards. Operate the column tilt pedal fig.2.8 to make the column return to the down position. Move the demounting head to firmly contact the rim fig.22. Position the left of the tyre lip above the tail of the demounting tool and the right under the hump fig.26.
- 6.2.3. Press down the right side of the tyre as hard as possible and operate the turntable pedal fig.2.11 to rotate the turntable clockwise to guide the lip into the wheel.

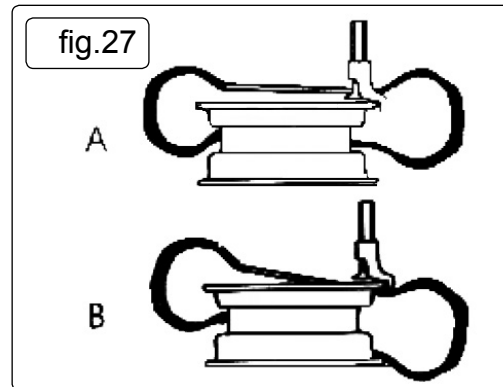
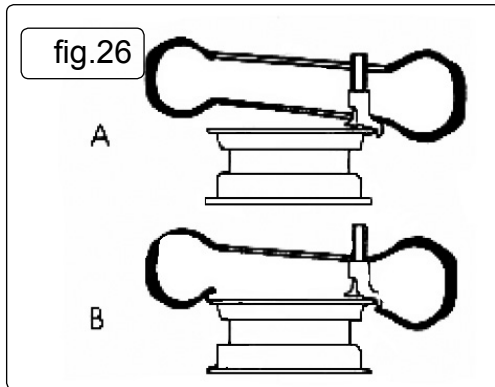

- 6.2.4. If an inner tube is required, raise up the demounting head and insert the tube into position.
- 6.2.5. Mount the demounting head again. Adjust the position of the upper lip. Operate the turntable rotation pedal to rotate the tyre. At this moment, continue pressing the lip. If the tyre deforms release the pedal at once. Rotate turntable in the opposite direction if required. Restore the tyre to its original condition and try to mount again.

6.3. Standard Inflation

- ☐ **WARNING!** Take care when inflating Tyre.
- 6.3.1. Check the air supply to see if the air connection is OK.
- 6.3.2. The machine is equipped with an inflation gauge for monitoring the inflation of the tyre and the inflation pressure.
- 6.3.3. Remove turntable clamps from the tyre.
- 6.3.4. Connect the inflation hose with the tyre air valve fig.28.
- 6.3.5. During inflation, check the pressure indicated on the pressure gauge does not exceed the scope specified by the manufacturer. The machine is equipped with a pressure regulating valve to prevent the pressure exceeding 3.5 bar. This can be adjusted dependent on requirements.

7. MAINTENANCE & REPAIR

- ✓ Only trained personnel should maintain this machine. To correctly use the tyre changer and prolong its working life, it is necessary to periodically maintain and repair according to the instruction manual.
 - ✓ Disconnect power and air supply before any maintenance. Release any residual air in system.
- 7.1. **The following should be done on a monthly basis.**
- 7.1.1. Keep the machine and working area clean.
 - 7.1.2. Clean the hexagonal shaft and horizontal arm fig.29.
 - 7.1.3. Use machine oil to lubricate.
 - 7.1.4. Clean the turntable jaws and its guides and use the lithium base oil to lubricate fig.30.
 - 7.1.5. Periodically check the lubrication oil level in the oil lubricator. If the oil level is lower than the oil scale, refill with SAE30 fig.31.
 - 7.1.6. Periodically drain the water in the water separator.
 - 7.1.7. Check and adjust the tension of the drive belt. Adjust nuts A and B to obtain the correct tension fig.32.
 - 7.1.8. Check for any loose bolts.
- 7.2. **Adjustment of the gap between the demounting tool and rim Vertical gap: adjust the hexagonal lock plate.**
- 7.2.1. Isolate the air supply and remove the vertical hexagonal shaft protective cover.
 - 7.2.2. If the gap is too big, you can adjust the upper and lower nut at the front end of the hexagonal lock plate downwards. If the gap is too small, adjust the upper and lower nut fig.33.1/fig.33.2 at the front end of the hexagonal lock plate upwards.

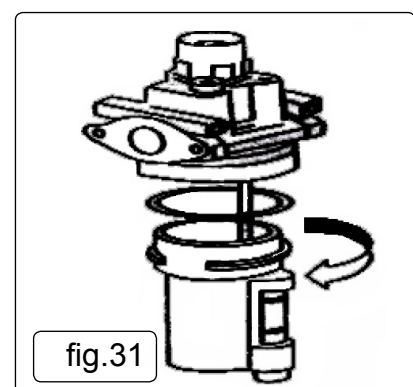
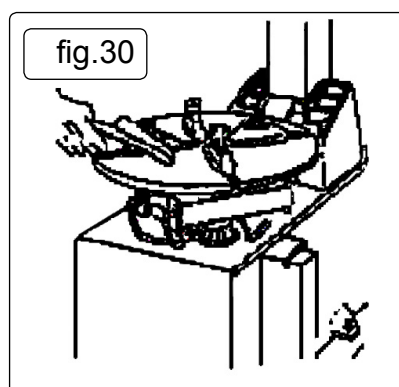
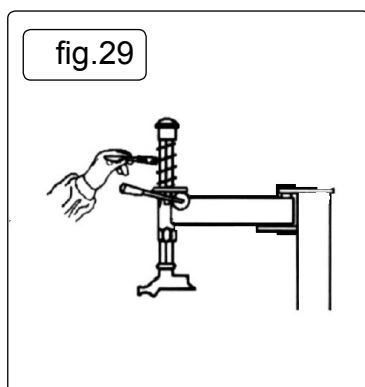
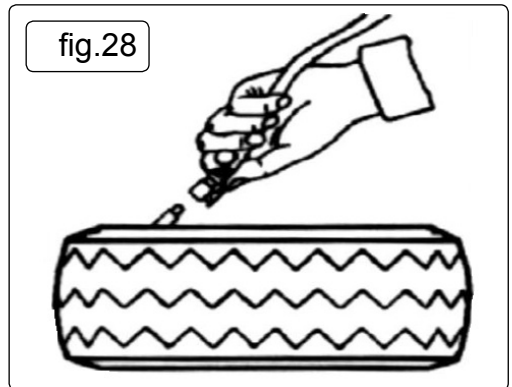

7.3. **Horizontal gap: adjust the horizontal arm lock plate**

7.3.1. Isolate the air supply and remove protective cover at the upper end of the horizontal arm. Using a spanner to loosen the lock cap on the M6 screw at the 2 ends. Adjust the M6 screw at two ends fig.33.3 meanwhile push the horizontal shaft until it moves smoothly. Then tighten the nut. Use the spanner to adjust the screw in the middle fig.33.4. Tighten the horizontal arm and observe the gap. When the gap is 2mm, lock the nut.

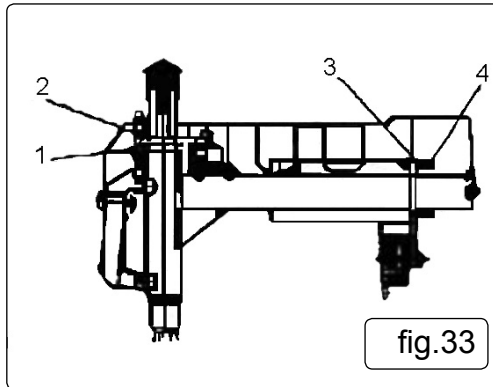
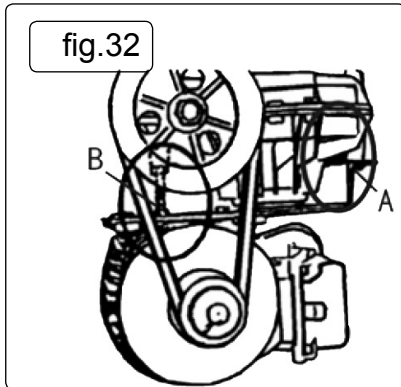

ENVIRONMENT PROTECTION

Recycle unwanted materials instead of disposing of them as waste. All tools, accessories and packaging should be sorted, taken to a recycling centre and disposed of in a manner which is compatible with the environment. When the product becomes completely unserviceable and requires disposal, drain any fluids (if applicable) into approved containers and dispose of the product and fluids according to local regulations.



WEEE REGULATIONS

Dispose of this product at the end of its working life in compliance with the EU Directive on Waste Electrical and Electronic Equipment (WEEE). When the product is no longer required, it must be disposed of in an environmentally protective way. Contact your local solid waste authority for recycling information.

Note: It is our policy to continually improve products and as such we reserve the right to alter data, specifications and component parts without prior notice.

Important: No Liability is accepted for incorrect use of this product.

Warranty: Guarantee is 12 months from purchase date, proof of which is required for any claim.

Sealey Group, Kempson Way, Suffolk Business Park, Bury St Edmunds, Suffolk. IP32 7AR



01284 757500



01284 703534



sales@sealey.co.uk



www.sealey.co.uk