



THREADED NUT RIVET KIT

MODEL NO: **AK396.V3**

Thank you for purchasing a Sealey product. Manufactured to a high standard, this product will, if used according to these instructions, and properly maintained, give you years of trouble free performance.

IMPORTANT: PLEASE READ THESE INSTRUCTIONS CAREFULLY. NOTE THE SAFE OPERATIONAL REQUIREMENTS, WARNINGS & CAUTIONS. USE THE PRODUCT CORRECTLY AND WITH CARE FOR THE PURPOSE FOR WHICH IT IS INTENDED. FAILURE TO DO SO MAY CAUSE DAMAGE AND/OR PERSONAL INJURY AND WILL INVALIDATE THE WARRANTY. KEEP THESE INSTRUCTIONS SAFE FOR FUTURE USE.



Refer to instructions



Wear eye protection

1. SAFETY

- WARNING!** Ensure Health & Safety, local authority and general workshop practice regulations are adhered to when using this equipment.
- ✓ Familiarise yourself with the application and limitations of the riveter, as well as the potential hazards.
- ✓ Maintain the riveter in good condition (use an authorised service agent).
- ✓ Replace or repair damaged parts. Use genuine parts only. Unauthorised parts may be dangerous and will invalidate the warranty.
- ✓ Keep the work area clean, uncluttered and ensure there is adequate lighting.
- ✓ Keep the riveter clean for best and safest performance.
- WARNING!** Always wear approved eye or face protection when operating the riveter.
- ✓ Keep children and unauthorised persons away from the working area.
- ✓ Check moving parts alignment on a regular basis.
- ✗ **DO NOT** hold the workpiece by hand. Secure unstable workpiece with a clamp, vice or other adequate holding device.
- ✓ Ensure the workpiece is correctly secured before operating the riveter.
- ✗ **DO NOT** use the riveter for any purpose other than that for which it is designed.
- ✗ **DO NOT** operate the riveter if any parts are damaged or missing, as this may cause failure and/or personal injury.
- ✓ When not in use return to the case and store in a safe, dry, childproof area.

2. INTRODUCTION

Suitable for blind rivets, rivet nuts and rivet studs in aluminium, steel and stainless steel. Swivel head with 360° movement gives greatly improved accessibility. Four nozzles for standard rivets, four mandrels for rivet nuts and three mandrels for rivet studs. Supplied with spanners and a selection of steel rivet nuts.

3. SPECIFICATION/CONTENTS

The AK396 kit is suitable for fitting the following size rivet, rivet nuts and rivet studs.

Rivets	2.4mm (3/32")	3.2mm (1/8")	4.0mm (5/32")	4.8mm (3/16")
Rivet Nuts	M3 x 0.5	M4 x 0.7	M5 x 0.8	M6 x 1.0
Rivet Studs	#	M4 x 0.7	M5 x 0.8	M6 x 1.0

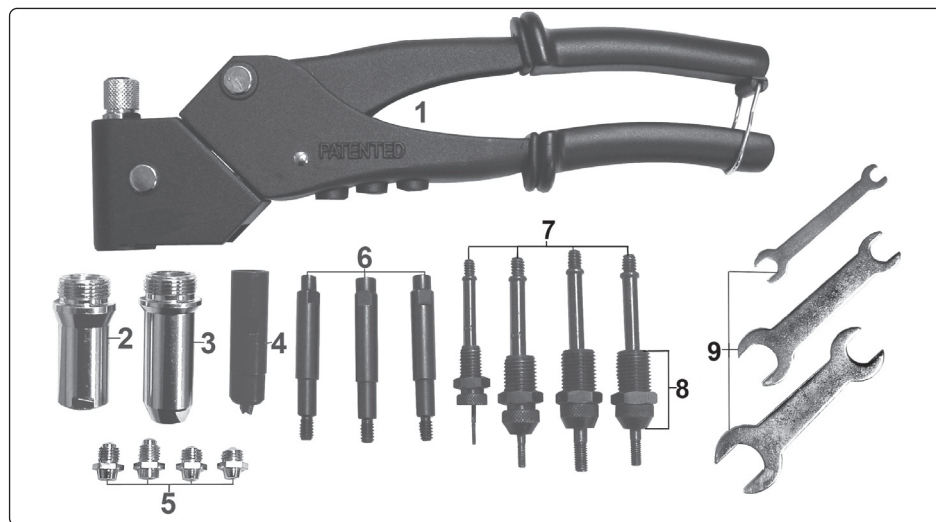

- | | | |
|--------------------------|---------------------------|--------------------------|
| 1. Riveting tool | 4. Jaw Case | 7. Mandrel for nuts (x4) |
| 2. Sleeve for mandrels | 5. Nosepiece (x4) | 8. Mandrel holder(x4) |
| 3. Sleeve for nosepieces | 6. Mandrel for studs (x3) | 9. Spanners (x3) |
- Not shown - four starter packs of 10 steel rivet nuts - M3x0.5, M4x0.7, M5x0.8, M6x1.0.

4. OPERATION

4.1. Rivets (Figs 1 and 2)

- 4.1.1. Assemble by fitting the jaw case (4) on to the tool and then fit sleeve (3). Select the correct size nosepiece (5) for the shaft diameter of the rivet and screw this into the sleeve.
- 4.1.2. With the riveter handles extended and open, fully insert the rivet shaft into the nosepiece (5).
- 4.1.3. Place rivet in hole in the workpiece and squeeze the riveter handles closed to deform the rivet.
- 4.1.4. If the rivet stem does not shear, open the handles, push the riveter further onto the stem and then close the handles again. Repeat as necessary.
- 4.1.5. When the stem shears, open the handles and remove the stem from the riveter.

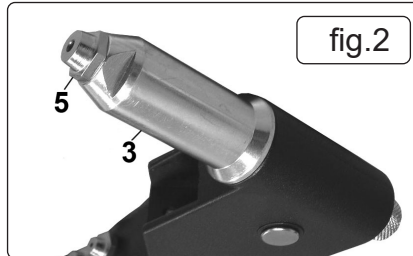
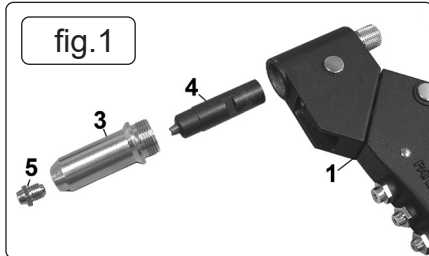

4.2. Threaded Nut Rivets (Figs 3 and 4)

- 4.2.1. Remove the pop rivet nosepiece, sleeve and jaw case from the riveter body.
- 4.2.2. Fit the sleeve for mandrel use (2) onto the riveter body.
- 4.2.3. Select the appropriate mandrel (7) for the size of the nut rivet to be used and screw this into the riveter (Note: left-hand thread).
- 4.2.4. Screw the corresponding mandrel holder (8) into the sleeve.
Note: If possible it is advisable to carry out a test on a sample workpiece to ensure that you are satisfied with the results before proceeding with your workpiece.
- 4.2.5. Prepare a sample of the workpiece material with a hole slightly larger than the nut rivet diameter.
- 4.2.6. Release the handles from the clip so that they are in the open position. Screw the nut rivet onto the mandrel until the end of the rivet is level with the end of the mandrel. The mandrel holder may need to be screwed further into the sleeve to enable this to be done. Then adjust the mandrel holder (8) so that it is touching the rivet head and lock in position with the lock nut (fig.4).
- 4.2.7. Place the nut rivet in the hole in the workpiece and press down so that the nut flange is held firmly against the upper face of the sample. Squeeze the riveter handles to compress the nut rivet. When the rivet has formed a retaining bulge against the rear face of the sample, unscrew the mandrel from the nut rivet by turning the knurled end of the draw bar (A) and then screw on a new nut rivet for the next operation.

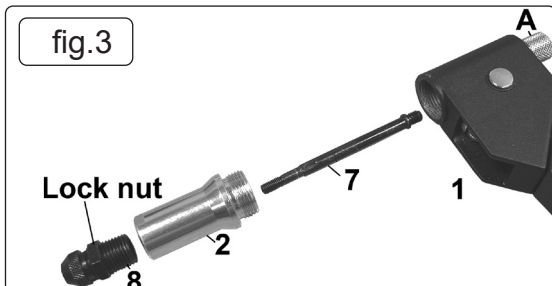

4.3. Stud Rivets (Figs 5 and 6)

- 4.3.1. Remove any previously used attachments from the riveter body.
- 4.3.2. Fit the sleeve for mandrel use (2) onto the riveter body.
- 4.3.3. Select the correct mandrel (6) for the stud rivet to be used, and screw the mandrel into the riveter (Note: left-hand thread).
- 4.3.4. Select the smallest mandrel holder (8) that the threaded end of the stud rivet to be used will slide into, and screw this into the sleeve (2).
Note: If possible it is advisable to carry out a test on a sample workpiece to ensure that you are satisfied with the results before proceeding with your workpiece.
- 4.3.5. Prepare a sample of the workpiece material with a hole slightly larger than the stud rivet diameter.
- 4.3.6. Release the handles from the clip so that they are in the open position. Screw the stud rivet into the mandrel as far as possible. The mandrel holder needs to be screwed fully down into the sleeve to enable this to be carried out. Then adjust the mandrel holder (8) if needed, so that it is touching the rivet head and lock in position with the lock nut (fig.6).
- 4.3.7. Place the stud rivet in the hole in the workpiece and press down so that the nut flange is held firmly against the upper face of the sample. Squeeze the riveter handles to compress the stud rivet. When the rivet has formed a retaining bulge against the rear face of the sample, unscrew the mandrel from the stud rivet by turning the knurled end of the draw bar (A) and then screw on a new stud rivet for the next operation.

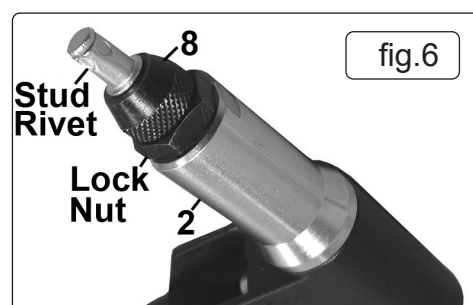
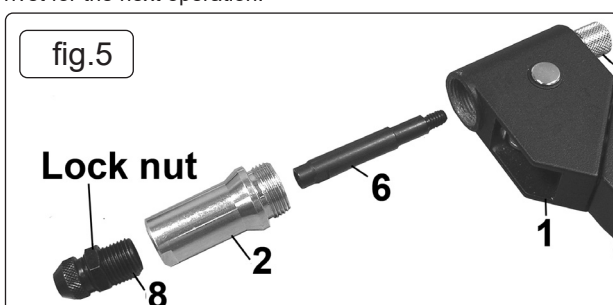

5. MAINTENANCE

- 5.3.1. Keep all pivots lightly oiled.
- 5.3.2. The jaw case assembly should be cleaned and oiled at regular intervals, depending on the frequency of use. The need for cleaning/jaw replacement will be indicated by the riveter failing to grip the rivet shaft.

Parts support is available for this product. Please log on to
www.sealey.co.uk, email sales@sealey.co.uk or telephone 01284 757500



ENVIRONMENT PROTECTION

Recycle unwanted materials instead of disposing of them as waste. All tools, accessories and packaging should be sorted, taken to a recycling centre and disposed of in a manner which is compatible with the environment. When the product becomes completely unserviceable and requires disposal, drain any fluids (if applicable) into approved containers and dispose of the product and fluids according to local regulations.

Note: It is our policy to continually improve products and as such we reserve the right to alter data, specifications and component parts without prior notice.

Important: No Liability is accepted for incorrect use of this product.

Warranty: Guarantee is 12 months from purchase date, proof of which is required for any claim.

Sealey Group, Kempson Way, Suffolk Business Park, Bury St Edmunds, Suffolk. IP32 7AR



01284 757500



01284 703534



sales@sealey.co.uk



www.sealey.co.uk