



MASKING TAPE DISPENSER STEP - UP

1 X 450MM ROLL

MODEL NO: MK64

Thank you for purchasing a Sealey product. Manufactured to a high standard, this product will, if used according to these instructions, and properly maintained, give you years of trouble free performance.

IMPORTANT: PLEASE READ THESE INSTRUCTIONS CAREFULLY. NOTE THE SAFE OPERATIONAL REQUIREMENTS, WARNINGS & CAUTIONS. USE THE PRODUCT CORRECTLY AND WITH CARE FOR THE PURPOSE FOR WHICH IT IS INTENDED. FAILURE TO DO SO MAY CAUSE DAMAGE AND/OR PERSONAL INJURY AND WILL INVALIDATE THE WARRANTY. KEEP THESE INSTRUCTIONS SAFE FOR FUTURE USE.



Refer to instruction manual

1. SAFETY

- ✓ Ensure the dispenser is on a flat, level floor before loading or using the dispenser as a step-up working platform.
- ✓ Be aware that the serrated paper cutting blade is sharp - handle with extreme care.
- ✗ **DO NOT** use the dispenser for any purpose other than that for which it was designed.

2. INTRODUCTION

Single roll dispenser accepts rolls up to 450mm. Features a step-up working platform. Automatically applies adhesive tape to edges of masking paper.

3. SPECIFICATION

Model no:MK64
Capacity: 1 x 450mm paper roll (not included)

4. CONTENTS

PART	DESCRIPTION	NO OFF
1	Top platform	1
2	End frames	2
3	Cutting bar	1
4	Paper spring	1
5	Paper mounting tube	1
6	Threaded fixing knobs	2
7	Nylon stops	2
8	Springs	2
9	Large washer (Ext.Ø44mm)	2
10	Rubber feet	4
11	Cross brace tube	1
12	Frame fixing bolts (M6 x 40mm)	8
13	Frame fixing nuts (M6)	6
14	Frame fixing washers (M6, ext.Ø12mm)	18
15	Masking tape reels	2
16	Reel fixing bolts (M6 x 80mm)	2
17	Butterfly nuts (M6)	4
18	Tubular sleeves	2
19	Sleeve washers (M6, ext.Ø14mm)	4

5. ASSEMBLY

- 5.1. Lay the Top Platform (1) onto a protected surface with the rubber pad, face downwards.
- 5.2. Place an end frame (2) upside down, at one end of the platform and align the holes in the frame with the holes in the upturned platform edge. Drop a washer (14) onto each of two M6 x 40mm bolts (12) and insert the bolts through the aligned holes from the outside of the top platform. Slide another washer (14) over the end of each bolt, followed by an M6 nut (13) and do the nut up, hand tight only at this stage.
- 5.3. Fix the second end frame (2) to the other end of the platform in the same way, ensuring that the holes in each frame for mounting the cutting bar (3) are both on the same side of the platform.

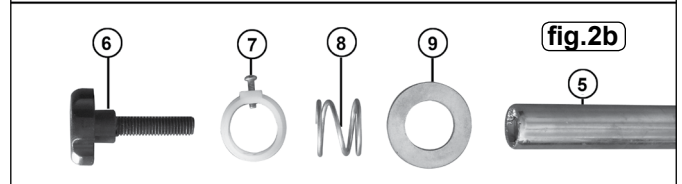
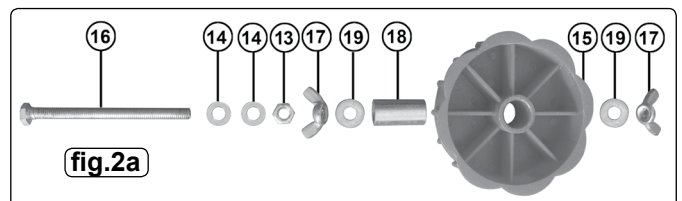
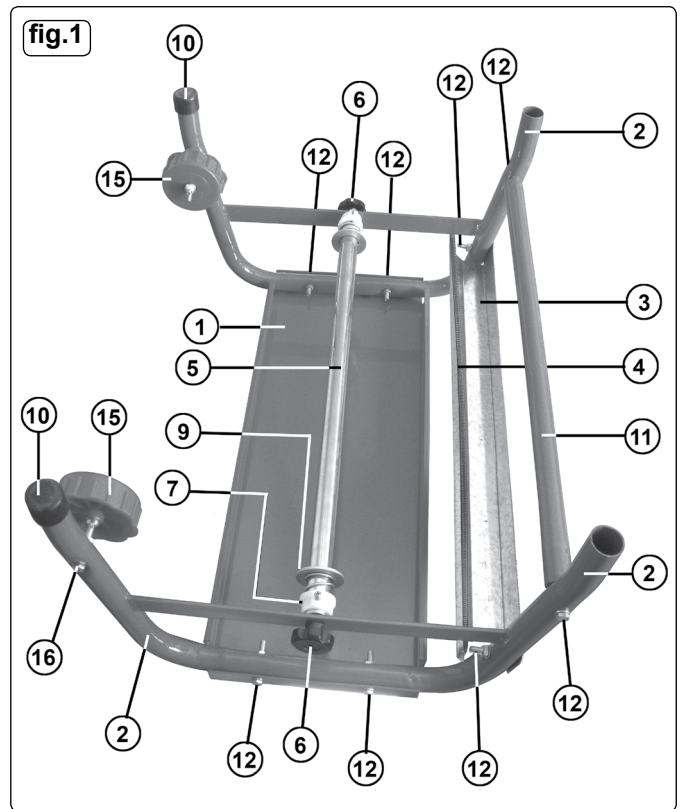

- 5.4. If not already in place, attach the paper spring (4) to the non-serrated edge of the cutting bar (3) as indicated in fig.1. Attach the cutting bar (3) to the end frames using two bolts (12), four washers (14) and two nuts (13).
- 5.5. Now attach the cross brace tube (11) to the same side of the end frames, directly above the cutting bar, as shown in fig.1. Drop a washer (14) onto each of two M6 x 40mm bolts (12) and insert the bolts through the end frames and screw them fully into the threaded inserts in the ends of the cross brace tube.
- 5.6. Now fully tighten all of the fixings so that the structure becomes rigid. Push the rubber feet (10) onto the end frames.
- 5.7. To mount the masking tape reels (see fig.2a), firstly insert the two reel fixing bolts (16) through the end frames as shown in fig.1. Use a washer (14) on either side of the frame tube and firmly fix both bolts using an M6 nut (13).
- 5.8. Screw a butterfly nut (17), the wrong way round, onto each bolt and wind it down close to the frame. Slide a washer (19) onto each bolt, followed by a tubular sleeve (18). Slide a plastic reel (15) onto each sleeve with the open side of the moulding facing outwards. Retain the assembly by using another washer (19) and a butterfly nut (17) on each side.
- 5.9. To mount a roll of paper, first insert the paper mounting tube (5) through the centre of the paper roll. Slide a large washer (9) onto each end of the tube followed by a spring (8) and a nylon stop (7). Adjust the position of these components on the tube to get the paper roll centralised and the nylon stops locked down with the springs exerting pressure on the paper roll.
- 5.10. Position the paper roll assembly into the frame and pass a threaded knob (6) through the end frame cross bar and screw it into each end of the paper tube (5), ensuring that the paper will come forwards off the top of the roll when the frame is the right way up. See fig.3.
- 5.11. Feed the end of the paper between the paper spring and the inner edge of the cutting bar as shown in fig.3. Make sure that your hands do not come into contact with the serrated cutting edge.
- 5.12. Push a reel of masking tape onto each tape reel ensuring that the tape is coming off the top of the reel towards the paper. Using the two butterfly nuts adjust the side to side position of each tape reel so that it appears to half overlap the paper roll when seen directly from behind.
- 5.13. Draw the tape from each reel in turn and stick it half on and half off the edge of the paper. Pull out the paper until its edges are fully taped.
- 5.14. If the tape is not feeding correctly onto the edge of the paper make further adjustments to the position of the tape reels using the butterfly nuts.
- 5.15. Adjust the tension on the two threaded knobs (6) so that the paper comes easily off the roll but does not overrun.
- 5.16. The Masking Paper Dispenser is now ready for use.



Parts support is available for this product. Please email sales@sealey.co.uk or telephone 01284 757500



ENVIRONMENT PROTECTION

Recycle unwanted materials instead of disposing of them as waste. All tools, accessories and packaging should be sorted, taken to a recycling centre and disposed of in a manner which is compatible with the environment. When the product becomes completely unserviceable and requires disposal, drain any fluids (if applicable) into approved containers and dispose of the product and fluids according to local regulations.

Note: It is our policy to continually improve products and as such we reserve the right to alter data, specifications and component parts without prior notice.

Important: No Liability is accepted for incorrect use of this product.

Warranty: Guarantee is 12 months from purchase date, proof of which is required for any claim.

Sealey Group, Kempson Way, Suffolk Business Park, Bury St Edmunds, Suffolk. IP32 7AR



01284 757500



01284 703534



sales@sealey.co.uk



www.sealey.co.uk