

# BODYSHOP

 [back to Section List](#)



## Air Accessory Kits

697

## Air Blow Guns

700

## Air Brush Kits

696

## Body Chassis Straightener

719

## Body Repair Kit & Accessories

715-718

## Caulking Guns

702

## Dust Free Sanding Kits

710

## Masking Paper Dispensers

703

## Metal Folders

731

## Paint Can Crusher

720

## Panel Dryers

704-705

## Panel Preparation Tools

721-723

## Panel Tools

724-730

## Panel/Bumper Stands & Racks

706-709

## Plastic Welding Kits

712

## Plunger Cans

704

## Pulling Accessories

715

## Riveters

732-736

## Sand/Shot Blasters

737-739

## Spray Gun Accessories

698-699

## Spray Guns

689-695

## Spray Gun Cleaning Tanks

695

## Vehicle Trolleys

714

## Wax Injector & Coating Guns

701

## Wheel Skates

713



**A SSG2**  
**General-Purpose Suction Feed Spray Gun - 1.5mm Set-Up**

Ideal for applying undercoat, adhesives and primers. Features adjustable paint flow and fan width controls. Supplied with aluminium screw-type suction feed pot. Suitable for use with water based paints. Alternative set-ups available separately.

Standard Set-Up:	1.5mm
Available Set-Ups:	1.2, 1.8, 2, 2.2, 2.5mm
Recommended Air Pressure:	60psi
Air Consumption:	5-11cfm
Pot Capacity:	800ml



**B SSG401**  
**General-Purpose Suction Feed Spray Gun - 1.5mm Set-Up**

Ideal for applying base coats. Features adjustable paint flow and fan width controls. Supplied with aluminium cam-action suction feed pot. Suitable for use with water based paints. Alternative set-ups available separately.

Standard Set-Up:	1.5mm
Available Set-Ups:	1.2, 1.8, 2, 2.2, 2.5mm
Recommended Air Pressure:	50psi
Air Consumption:	5-11cfm
Pot Capacity:	1000ml



**C S775**  
**General-Purpose Suction Feed Spray Gun - 1.7mm Set-Up**

Ideal for automotive refinishing. Supplied with 1.7mm set-up. Fitted with air regulator control. Suitable for use with water based paints. Supplied with cam-action suction pot. Alternative set-ups available separately.

Standard Set-Up:	1.7mm
Available Set-Ups:	1.5, 1.8, 2mm
Recommended Air Pressure:	30-70psi
Air Consumption:	12-15cfm
Pot Capacity:	900ml



**D S701**  
**Workshop Gold Series Suction Feed Spray Gun - 1.8mm Set-Up**

Spray gun with gold finish handle suitable for applying finishing coats. Supplied with cam-action suction pot. Superbly balanced gun. Suitable for use with water based paints. Alternative set-ups available separately.

Standard Set-Up:	1.8mm
Available Set-Ups:	1.5, 2mm
Recommended Air Pressure:	30-70psi
Air Consumption:	7-12cfm
Pot Capacity:	900ml



**E SSG1**  
**Workshop Series Suction Feed Spray Gun - 1.8mm Set-Up**

Superbly balanced spray gun suitable for applying finishing coats. Supplied with cam-action suction pot and fitted with air regulator control. Suitable for use with water based paints. Alternative set-up available separately.

Standard Set-Up:	1.8mm
Available Set-Up:	2mm
Recommended Air Pressure:	30-70psi
Air Consumption:	7-12cfm
Pot Capacity:	900ml



**F AR01**  
**On-Gun Air Pressure Regulator/Gauge**

On-Gun Air Pressure Regulator/Gauge. Just one of a comprehensive range of quality spray gun accessories.

Maximum Pressure:	140psi
Maximum Flow:	18cfm @ 90psi



**G SC138**  
**1L Alloy Paint Pot with Cam-Action Lid**

1L Aluminium paint pot with cam action lid. Fitted with 3/8"BSPP thread, for use with most suction feed spray guns.

Thread Size:	3/8"BSPP
Applications:	SSG401, S775, S701, SSG1, S717, HVLP740



**D ARD01**  
**On-Gun Digital Pressure Regulator/Gauge**  
 On/off button with adjustable auto-off function for extended battery life. Small and compact with composite body. Pressure can be displayed in psi, bar, kg/cm<sup>2</sup> or KPa.

<b>Maximum Pressure:</b>	160psi/11bar/11.25kg/cm <sup>2</sup> /1100kPa
<b>Maximum Flow:</b>	20cfm @ 100psi

**A-C SEE BELOW**

**General-Purpose Suction Feed Spray Guns**

Suction feed spray guns, ideal for automotive refinishing. 2-Stage trigger control. Adjustable spray width and fluid flow. Maintenance tools supplied. Available in three standard set-up sizes; 1.7, 2 and 2.5mm, each finished in a different colour for easy identification. Supplied with 1000ml aluminium cup.

	<b>A</b>	<b>B</b>	<b>C</b>
<b>Model No:</b>	S717	S720	S725
<b>Standard Set-Up:</b>	1.7mm	2mm	2.5mm
<b>Available Set-Ups:</b>	2, 2.5mm	1.7, 2.5mm	1.7, 2mm
<b>Recommended Air Pressure:</b>	57psi	57psi	57psi
<b>Air Consumption:</b>	3-4cfm	3-4cfm	3-4cfm
<b>Pot Capacity:</b>	1000ml	1000ml	1000ml

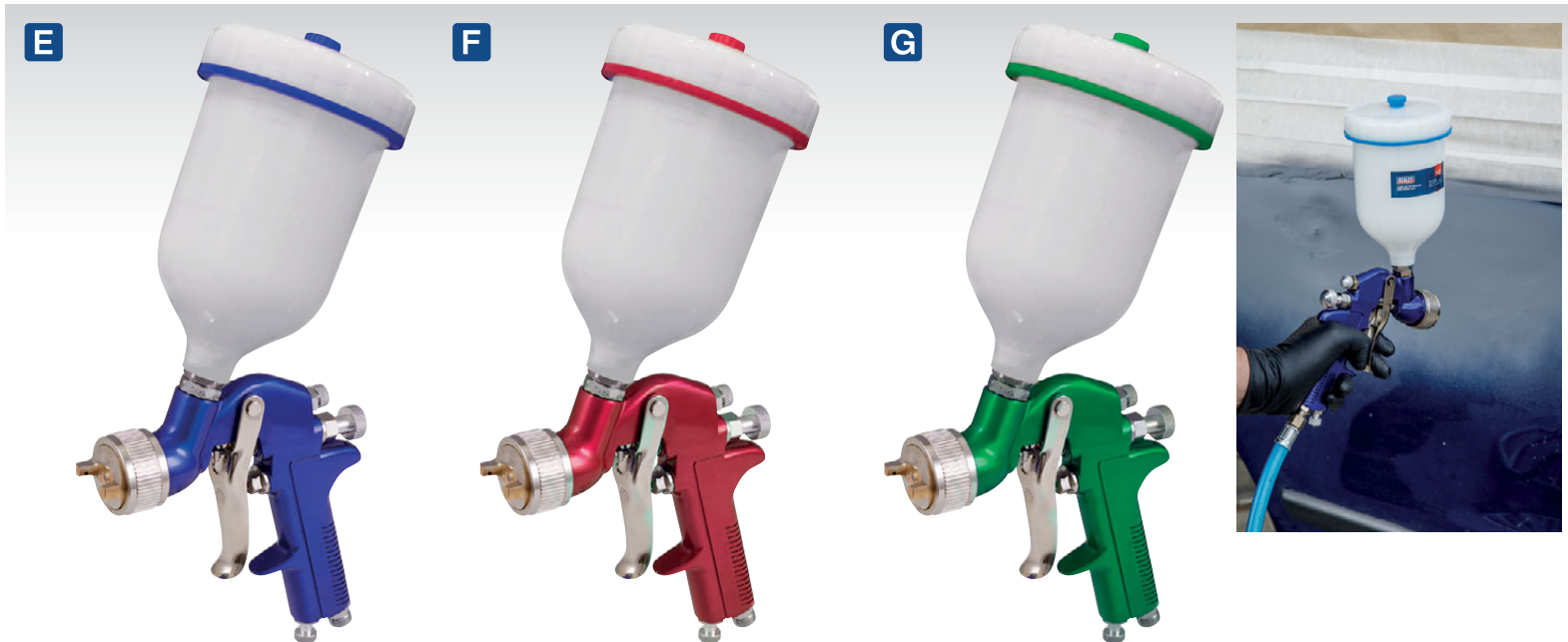

**E-G SEE BELOW**

**General-Purpose Gravity Feed Spray Guns**

Gravity feed spray guns, ideal for automotive refinishing. 2-Stage trigger control. Adjustable spray width and fluid flow. Maintenance tools supplied. Available in three standard set-up sizes; 1.3, 1.4 and 1.7mm, each finished in a different colour for easy identification.

	<b>E</b>	<b>F</b>	<b>G</b>
<b>Model No:</b>	S713G	S714G	S717G
<b>Standard Set-Up:</b>	1.3mm	1.4mm	1.7mm
<b>Available Set-Ups:</b>	1.4, 1.7mm	1.3, 1.7mm	1.3, 1.4mm
<b>Recommended Air Pressure:</b>	50psi	50psi	50psi
<b>Air Consumption:</b>	2.5-3.5cfm	2.5-3.5cfm	2.5-3.5cfm
<b>Pot Capacity:</b>	600ml	600ml	600ml





**A**

**Siegen**



**A S631**  
**General-Purpose Gravity Feed Touch-Up Spray Gun - 1mm Set-Up**

Ideal for blowing-in small areas of panel and detail refinishing where fine control of paint and air is necessary. Features air, fluid and spray pattern adjustment for full user control. Brass air cap with steel needle and nozzle. Alternative set-up available separately.

Standard Set-Up:	1mm
Available Set-Up:	0.8mm
Recommended Air Pressure:	43psi
Air Consumption:	3-5cfm
Pot Capacity:	125ml



**B**

**Siegen**



**B S641G**  
**General-Purpose Gravity Feed Spray Gun - 1.4mm Set-Up**

Standard set-up and economy price make this spray gun ideal for applying various materials including adhesives, base coats and finishing coats. Round/flat fan control allows spray pattern to be adjusted for any job. Brass air cap with steel needle and nozzle. Alternative set-ups available separately.

Standard Set-Up:	1.4mm
Available Set-Ups:	1.7, 1.8, 2mm
Recommended Air Pressure:	45psi
Air Consumption:	4cfm
Pot Capacity:	600ml



**C**

**Siegen**



**C S642G**  
**General-Purpose Gravity Feed Spray Gun - 1.8mm Set-Up**

Standard set-up and economy price make this spray gun ideal for applying various materials including adhesives, primers, base coats and finishing coats. Round/flat fan control allows spray pattern to be adjusted for any job. Brass air cap with steel needle and nozzle. Alternative set-ups available separately.

Standard Set-Up:	1.8mm
Available Set-Ups:	1.4, 1.7, 2mm
Recommended Air Pressure:	45psi
Air Consumption:	4cfm
Pot Capacity:	600ml



**D**

**Siegen**



**D S775G**  
**General-Purpose Gravity Feed Spray Gun - 1.3mm Set-Up**

Gravity feed spray gun, ideal for automotive refinishing. 2-Stage trigger control. Adjustable spray width and fluid flow. Suitable for use with water based paints. Maintenance tools supplied. Alternative set-ups available separately.

Standard Set-Up:	1.3mm
Available Set-Ups:	1.5, 1.8, 2mm
Recommended Air Pressure:	30-70psi
Air Consumption:	12-15cfm
Pot Capacity:	600ml



**E-G**



**E-G SEE BELOW**  
**General-Purpose Gravity Feed Spray Guns**

Ideal for applying undercoats, primers and adhesives. Features adjustable paint flow and fan width controls. Supplied with composite gravity feed pot. Suitable for use with water based paints. Alternative set-ups available separately.

	<b>E</b>	<b>F</b>	<b>G</b>
Model No:	SSG501	SSG502	SSG503
Standard Set-Up:	2.2mm	1.8mm	1.5mm
Available Set-Ups:	1.5, 1.8mm	1.5, 2.2mm	1.8, 2.2mm
Recommended Air Pressure:	50psi	50psi	50psi
Air Consumption:	4.5-8cfm	4.5-8cfm	4.5-8cfm
Pot Capacity:	600ml	600ml	600ml



**H**

**H ACH60**  
**1/4" BSP High Flow Air Tool Coupling Kit**

Kit comprises male threaded coupling body together with male and female threaded adaptors. Fitted with 1/4" BSP threads. Suitable for most air tool applications. Free airflow rate at 100psi(7bar): 130cfm(3681L/min).

Thread Size:	1/4" BSP
Pack Qty:	3pc Kit



**E**





A



**A SSG5**  
**Workshop Series Gravity Feed Spray Gun - 2mm Set-Up**

Ideal for applying undercoats, primers and adhesives. Features adjustable paint flow, fan width and air regulator controls. Supplied with composite gravity feed pot. Suitable for use with water based paints. Alternative set-ups available separately.

Standard Set-Up:	2mm
Available Set-Ups:	1.2, 1.4, 1.8mm
Recommended Air Pressure:	50psi
Air Consumption:	7-14cfm
Pot Capacity:	600ml



B



**B S701G**  
**Gold Series Gravity Feed Spray Gun - 1.4mm Set-Up**

Suitable for applying finishing coats. 2-Stage trigger control and 600ml plastic gravity feed pot. Adjustable spray width and fluid flow. Maintenance tools supplied. Suitable for use with water based paints. Alternative set-ups available separately.

Standard Set-Up:	1.4mm
Available Set-Ups:	1.7, 2mm
Recommended Air Pressure:	43psi
Air Consumption:	16cfm
Pot Capacity:	600ml



C

HVLP



**C HVL731**  
**Workshop Series HVLP Gravity Feed Touch-Up Spray Gun - 0.8mm Set-Up**

Ideal for blowing-in small areas of panel where fine control of paint and air is necessary. Brass air cap with stainless steel needle and nozzle make this HVLP gun suitable for water based paint. Alternative set-up available separately.

Standard Set-Up:	0.8mm
Available Set-Up:	1mm
Recommended Air Pressure:	43psi
Air Consumption:	9cfm
Pot Capacity:	100ml



D

HVLP



**D HVL741**  
**Workshop Series HVLP Gravity Feed Spray Gun - 1.3mm Set-Up**

Suitable for applying top coats. Round/flat fan control allows spray pattern to be adjusted for any job. Brass air cap with stainless steel needle and nozzle make this HVLP gun suitable for water based paint. Alternative set-ups available separately.

Standard Set-Up:	1.3mm
Available Set-Ups:	1.2, 1.4, 1.7, 2mm
Recommended Air Pressure:	43psi
Air Consumption:	15cfm
Pot Capacity:	600ml



E

HVLP



**E HVL742**  
**Workshop Series HVLP Gravity Feed Spray Gun - 2mm Set-Up**

Ideal for applying high viscosity paints such as primer or undercoat. Round/flat fan control allows spray pattern to be adjusted for any job. Aluminium air cap with stainless steel needle and nozzle make this HVLP gun suitable for water based paint. Alternative set-ups available separately.

Standard Set-Up:	2mm
Available Set-Ups:	1.4, 1.7mm
Recommended Air Pressure:	43psi
Air Consumption:	15cfm
Pot Capacity:	600ml



F

HVLP



**F HVL740**  
**Workshop Series HVLP Suction Feed Spray Gun - 1.7mm Set-Up**

Round/flat fan control allows spray pattern to be adjusted for any job. 1.7mm Set-up is ideal for applying primers, undercoats and adhesives. Brass air cap with stainless steel needle and nozzle make this HVLP gun suitable for water based paint. Alternative set-ups available separately.

Standard Set-Up:	1.7mm
Available Set-Ups:	1.2, 1.3, 1.4, 2mm
Recommended Air Pressure:	43psi
Air Consumption:	16cfm
Pot Capacity:	800ml



**A HVL736**  
**HVLP Gravity Feed Touch-Up Spray Gun - 0.8mm Set-Up**

Professional gravity feed touch-up spray gun with 0.8mm set-up, ideal for small panels. Brass air cap with stainless steel needle and nozzle suitable for water based paints. Features air and paint flow controls for fine adjustment of spray pattern. Fully polished body resists corrosion and makes for easy cleaning. Alternative set-up available separately.

Standard Set-Up:	0.8mm
Available Set-Up:	1mm
Recommended Air Pressure:	29psi
Air Consumption:	9cfm
Pot Capacity:	125ml



**B HVL746**  
**HVLP Gravity Feed Spray Gun 1.3mm Set-Up**

Professional gravity feed spray gun with 1.3mm set-up, ideal for applying top coats. Brass air cap with stainless steel needle and nozzle suitable for water based paints. Features air and paint flow controls for fine adjustment of spray pattern. Fully polished body resists corrosion and makes for easy cleaning. Alternative set-ups available separately.

Standard Set-Up:	1.3mm
Available Set-Ups:	1.7, 2mm
Recommended Air Pressure:	29psi
Air Consumption:	15cfm
Pot Capacity:	600ml



**D HVL774**  
**HVLP Top Coat/Touch-Up Gravity Feed Spray Gun Set**

Professional gravity feed spray gun set comprising of Model No's **A** HVL736 and **B** HVL746. Brass air cap with stainless steel needle and nozzle suitable for water based paints. Fully polished body resists corrosion and makes for easy cleaning. Alternative set-ups available separately. See model specification for details.



**C SGL01**  
**5W SMD LED Rechargeable Spray Gun Light**

Rechargeable 100lm spray gun light with a high Colour Rendering Index (CRI 90) suitable for accurate colour matching. Suitable for home or bodyshop use. Manufactured to fit most guns with its Ø25-45mm clamp. Ideal for low light areas such as vehicle chassis and interior where traditional booth lights do not reach adequately. Supplied with Type-C USB cable.

Battery:	3.7V 0.75Ah Li-ion
Charging Time:	2.5hr
Clamp Size:	Ø25-45mm
CRI Rating:	90
IP Rating:	IP65
LED Type:	5W SMD LED
Operating Time:	High/Low: 4/11hr



**E AH5R**  
**Extra-Heavy-Duty Air Hoses with 1/4" BSP Unions**

For more information on our Extra-Heavy-Duty Air Hose range, see page 789.



**A**

**Premier**

**HVLP**



**A HVLPO1**

**Professional HVLP Gravity Feed Spray Gun - 1.3mm Set-Up**

Gravity feed spray gun designed for applying base coats. Features air and paint flow controls for fine adjustment of spray pattern. HVLP technology and precision engineering delivers consistent and unrivalled results. Suitable for solvent and water based paints.

Standard Set-Up:	1.3mm
Available Set-Ups:	1.4, 1.7mm
Recommended Air Pressure:	30-43psi
Air Consumption:	14cfm
Pot Capacity:	600ml

**D**

**Premier**

**HVLP**



**D HVLPO4**

**Professional HVLP Gravity Feed Touch-Up Spray Gun - 1mm Set-Up**

Gravity feed spray gun with 1mm set-up, ideal for blowing-in small areas of panel where fine control of paint and air is necessary. Features air and paint flow controls for fine adjustment of spray pattern. HVLP technology and precision engineering delivers consistent and unrivalled results. Brass air cap with stainless steel needle and nozzle suitable for solvent and water based paints.

Standard Set-Up:	1mm
Available Set-Up:	0.8mm
Recommended Air Pressure:	22psi
Air Consumption:	7cfm
Pot Capacity:	100ml

**B**

**Premier**

**LVLP**



**B LVLPO1**

**Professional LVLP Gravity Feed Spray Gun - 1.4mm Set-Up**

Gravity feed spray gun designed for applying base coats. Features air and paint flow controls for fine adjustment of spray pattern. LVLP technology gives a superior finish with very low paint wastage. Suitable for solvent and water based paints.

Standard Set-Up:	1.4mm
Available Set-Ups:	1.2, 1.3, 1.7, 1.8mm
Recommended Air Pressure:	17-22psi
Air Consumption:	8.2cfm
Pot Capacity:	600ml

**E NEW**

**Premier**

**HVLP**



**E HVLPO5**

**Professional HVLP Gravity Feed Spray Gun - 1.3mm Set-Up**

Gravity feed spray gun designed for applying clear and base coats. Features air and paint flow controls for fine adjustment of spray pattern with a maximum size of 280mm. HVLP technology and precision engineering delivers consistent and unrivalled results. No rubber O-ring design features non-perishable material for solvent resistance and long-life. Stainless steel fluid passages, needle, nozzle, air cap and air valve suitable for solvent and water based paints.

Standard Set-Up:	1.3mm
Available Set-Ups:	1.2, 1.4mm
Recommended Air Pressure:	29-32psi
Air Consumption:	14.1cfm
Pot Capacity:	600ml

**C**

**Premier**

**MVMP**



**C SP01**

**Professional SP Gravity Feed Spray Gun - 1.4mm Set-Up**

Gravity feed spray gun using standard pressure which creates a flat and smooth fan pattern ideal to get the best clear finishing coats. Air cap engineered to provide 26psi of mist pressure for fast application and extended working distance. Greater efficiency than HVLP and less material wastage than conventional spray guns. MVMP technology and precision engineering delivers consistent and unrivalled results. Features air and fluid flow controls for fine adjustment of spray pattern.

Standard Set-Up:	1.4mm
Available Set-Ups:	1.2, 1.3, 1.7, 1.8mm
Recommended Air Pressure:	30-43psi
Air Consumption:	10.6cfm
Pot Capacity:	600ml

**E**

Quick release retaining ring for easy air cap changes.

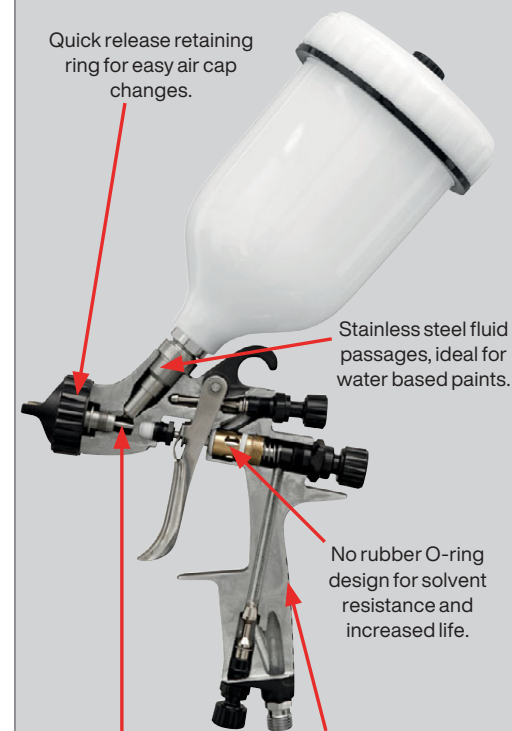

Stainless steel fluid passages, ideal for water based paints.

No rubber O-ring design for solvent resistance and increased life.

Stainless steel nozzle and needle.

Lightweight die-cast aluminium body.





**A-B SEE BELOW**

**Pressure Pot System Components**

Pressure pot components compatible with Model No. SSG1P Pressure Feed Spray Gun Kit. Supplied with 1.8mm set-up.

<b>Model No:</b>	<b>Description:</b>
<b>A</b> SSG1P/1	Spray Gun Head
<b>B</b> SSG1P/3	2L Pressure Pot



**C-D SEE BELOW**

**HVLP Pressure Pot System Components**

Individual components for use with Model No. HVLP-79/P Pressure Pot Spray Gun. Supplied with 1.7mm set-up.

<b>Model No:</b>	<b>Description:</b>
<b>C</b> HVLP-79/P1	Spray Gun Head
<b>D</b> HVLP-79/P2	1.37m Hose (x2)

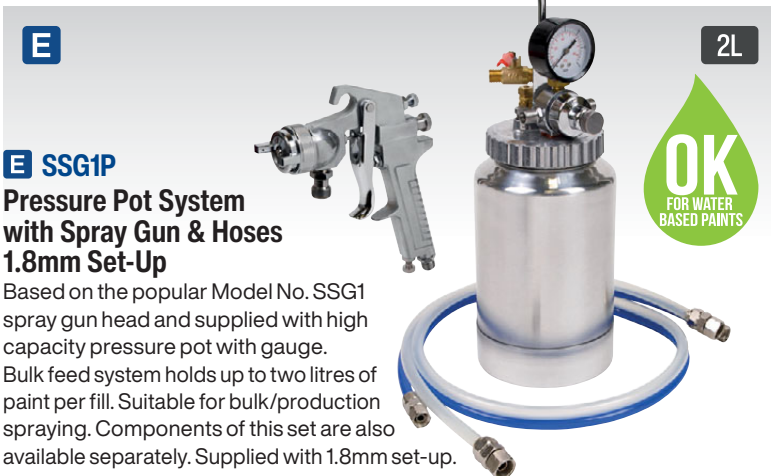

**E SSG1P Pressure Pot System with Spray Gun & Hoses 1.8mm Set-Up**

Based on the popular Model No. SSG1 spray gun head and supplied with high capacity pressure pot with gauge. Bulk feed system holds up to two litres of paint per fill. Suitable for bulk/production spraying. Components of this set are also available separately. Supplied with 1.8mm set-up.

<b>Contents:</b>	SSG1P/1, HVLP-79/P2, SSG1P/3
<b>Standard Set-Up:</b>	1.8mm
<b>Available Set-Ups:</b>	1.4, 2, 2.5mm
<b>Recommended Air Pressure:</b>	50psi
<b>Air Consumption:</b>	5-10cfm
<b>Pot Capacity:</b>	2L



**F HVLP-79/P HVLP Pressure Pot System with Spray Gun & Hoses 1.7mm Set-Up**

HVLP technology delivers consistent and unrivalled results. Bulk feed system holds up to two litres of paint per fill. This unit is perfectly suited to the commercial refinishing shop. Components of this set are also available separately. Supplied with 1.7mm set-up.

<b>Contents:</b>	HVLP-79/P1, HVLP-79/P2, SSG1P/3
<b>Standard Set-Up:</b>	1.7mm
<b>Available Set-Ups:</b>	1.2, 1.4, 1.5, 1.8, 2, 2.5mm
<b>Recommended Air Pressure:</b>	43psi
<b>Air Consumption:</b>	6-10cfm
<b>Pot Capacity:</b>	2L

**G-H SEE BELOW Spray Gun Cleaning Tanks**

Fully automatic operation - close lid to start and open lid to stop. Corrosion resistant tanks suitable for containing water and detergent necessary for cleaning water based spray guns. Powerful and reliable piston pump system.

	<b>G</b>	<b>H</b>
<b>Model No:</b>	SM24/1	SM23/2
<b>Gun/Pot Capacity:</b>	1/1	2/2
<b>Width:</b>	415mm	470mm
<b>Depth:</b>	468mm	572mm
<b>Height:</b>	1030mm	1300mm
<b>Pump:</b>	Pneumatic	Pneumatic
<b>Recommended Air Pressure:</b>	30-50psi	30-50psi
<b>Air Consumption:</b>	2-4cfm	2-4cfm

**SAFETY EQUIPMENT**

For our full range of nitrile gauntlets, spectacles and safety equipment, see pages 1277 to 1301.



A

**A AB931****Air Brush Kit**

Gravity fed air brush with composite body. Suitable for blowing-in small areas of panel. Kit includes gravity cup, propellant adaptor\*, 1.5m of small-bore hose and 1/4" reduction nipple. Supplied in storage case.

<b>Working Pressure:</b>	15-45psi
<b>Nozzle Size:</b>	0.3mm

\*Propellant not included

B

**B AB932****Air Brush Kit**

Metal body with suction bottle or thimble feed options. Paint delivery controlled on single thumb screw. Supplied with 0.35mm nozzle. Includes two 22cc glass pots, one 5cc metal cup, 1.6m small-bore hose, 1/4" reduction nipple, spanner and hanging bracket. Supplied in storage case.

<b>Working Pressure:</b>	15-50psi
<b>Nozzle Size:</b>	0.35mm

C

**C AB9321****Gravity Feed Air Brush Kit**

Metal body construction with built-in gravity feed pot. Double-action trigger providing precision control of paint flow. Supplied fitted with 0.3mm nozzle. Includes alternative 0.2 and 0.5mm set-ups, 1.8m small-bore hose, adjustment spanner and pipette. Supplied in storage case.

<b>Working Pressure:</b>	15-50psi
<b>Nozzle Sizes:</b>	0.2, 0.3, 0.5mm
<b>Cup Capacity:</b>	7cc

D



230V

Oil Free

**D AB900****Mini Air Brush Compressor**

Quiet running piston pump, powered by a 122W electric motor - suitable for most air brushes. Requires no lubrication and the air supply from the unit is oil-free. Supplied with an air filter regulator and pressure gauge.

<b>Power:</b>	122W
<b>Supply/Plug Type:</b>	230V/3-Pin
<b>Power Supply Cable Length:</b>	1.8m
<b>Free Air Delivery:</b>	0.8cfm
<b>Maximum Air Pressure:</b>	50psi
<b>Outlet Thread:</b>	1/8" BSP

E

**E AB936****10pc Mini Air Brush Kit Gravity/Suction Feed**

Comprehensive mini air brush kit, including suction and gravity feed pots. Designed for detailed application. Double-action trigger providing precision control of paint flow. Supplied in storage case.

<b>Working Pressure:</b>	15-50psi
<b>Nozzle Sizes:</b>	0.2, 0.3, 0.4, 0.5mm
<b>Cup Capacity:</b>	7, 9, 22cc





**A SA923**

**Paraffin Spray Gun - Large Inlet**

Metal tank with large diameter fluid aperture which aids filling and cleaning of tank. Suitable for applying degreasing and cleaning agents. Fitted with fluid/air control valve.

**Inlet Size:** 1/4" BSP



**B SA320K**

**19pc Air Blow Gun Kit**

Die-cast metal body with moulded handle and hanging point. Palm type gun with thumb trigger control. Supplied with jet and safety nozzle. Quick release coupling/adaptor kit and tyre pressure gauge. Ø1/4"(6mm) x 7m PE air hose with 1/4" BSP Male connectors. Maximum operating pressure 110psi.

**Inlet Size:** 1/4" BSP

**Contents:** Ø1/4"(6mm) x 7m PE Air Hose with 1/4" BSP Male Connectors, Air Blow Gun, Female 1/4" BSP Quick Coupling (x2), Blow Gun Attachment Adaptor, Blow Gun Safety Nozzle, 1/4" BSP Male/Male Adaptor, Blow Gun Nozzle, Roll of PTFE Tape, Tapered Blow Gun Nozzle, Inflating Needles (x2), 1/4" BSP Male Quick Connector (x3), 1/4" BSP Female Quick Connector (x2), 1/4" BSP Female/Female Adaptor, Tyre Pressure Gauge



**C SA33/S**

**5pc Air Accessory Kit**

Air tools and accessories suitable for all leading makes of compressor. Includes suction feed spray gun with bayonet type pot lid, tyre inflator with gauge, paraffin/detergent spray gun, air blow gun and coiled air hose. Components are fitted with 1/4" BSP threaded unions. Also available individually, see below.

Model No:	Kit Contains:
1 SA332	Tyre Inflator with Gauge
2 SA333	Paraffin Spray Gun
3 SA334	Air Blow Gun
4 SA335	PE Coiled Air Hose
5 N/A	Suction Feed Spray Gun



**D SA33G**

**5pc Air Accessory Kit**

Air tools and accessories suitable for all leading makes of compressor. Includes gravity feed spray gun, tyre inflator with gauge, paraffin/detergent spray gun, air blow gun and coiled air hose. Components are fitted with 1/4" BSP threaded unions.



**E-H SEE BELOW**

**Air Accessories with Quick Release Couplings**

Air tools and accessories suitable for all leading makes of compressor. Tyre inflator with gauge, paraffin/detergent spray gun, air blow gun and coiled air hose all fitted with quick release air line couplings. Sold individually, see below.

Model No:	Description:
E SA302	Tyre Inflator with Gauge
F SA303	Paraffin Spray Gun
G SA304	Air Blow Gun
H SA305	PE Coiled Air Hose



**I HVLP3000**

**700W HVLP Spray Gun Kit - 230V**

700W Electric motor provides continuous high volume of air for even paint coverage. Extendable handle and hose storage provides easy manoeuvrability. Suitable for interior and exterior use, applying water and oil based paints, lacquers, preservatives and stains.

<b>Power:</b>	700W
<b>Maximum Air Pressure:</b>	4.35psi
<b>Supply/Plug Type:</b>	230V/3-Pin
<b>Standard Set-Up:</b>	2.5mm
<b>Pot Capacity:</b>	800ml
<b>Hose Length:</b>	3m
<b>Power Supply Cable Length:</b>	2m
<b>Weight:</b>	3kg



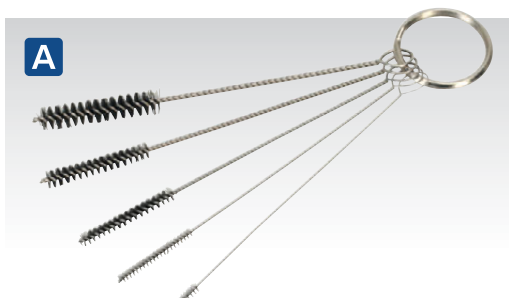

**A BSGC4**  
**5pc Mini Brush Spray Gun Cleaning Set**  
 Ideal for cleaning needles, nozzles and air caps from spray guns after use. Suitable for use with thinners and cleaning solvents.



**B BSGC/3**  
**3pc Spray Gun Cleaning Brush Set**  
 Ideal for cleaning the inside and outside of spray guns after use. Suitable for use with thinners and cleaning solvents.



**C BSGC2**  
**20pc Spray Gun Cleaning Set**  
 Various sized brushes and probes suitable for many cleaning applications.

**Contents:** Bristle Brushes; 130mm, 150mm, 210mm, 210mm (Large), Soft Brushes; 150mm (x2), 200mm, 180mm Brush with 50mm Soft-Fill, Wire Probe, Wooden Probe (x10), Needle Lubricant



**D BSGC5**  
**22pc Spray Gun Cleaning Set**  
 Comprehensive cleaning set with a range of soft, medium, hard and brass bristle brushes. Includes precision brush/probe sets and empty bottle for lubricant. Suitable for various applications. Supplied in storage case.

**Contents:** 95mm Mini Brushes (x6), Soft/Medium Brushes; 155, 210, 310mm (Angled), 155mm Brass Brush, 170mm Brush with 35mm Hard Bristles, Precision Brushes (x3) & Holder, Precision Probes (x6) & Holder, Lubricant



**E MK78**  
**Paint Dirt Removal Pen with Needle Set**  
 Aluminium pen with quick change needles. Designed to remove particles from wet paint and prevent bubbles. Supplied with needle set and a storage case.

**Consumable Parts:** BSC01 - Paint Dirt Removal Needle Set - Pack of 10

**Contents:** 1x Aluminium Pen, 1x Paint Dirt Removal Needle Set



**F AR01**  
**On-Gun Air Pressure Regulator/Gauge**

**Maximum Pressure:** 140psi  
**Maximum Flow:** 18cfm @ 90psi

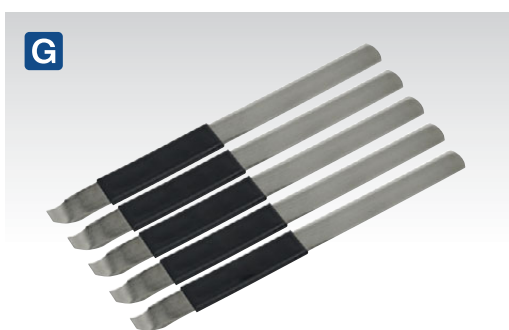

**G PA05**  
**Paint Can Opener/Stirrer - Pack of 5**  
 Carbon steel paint can opener with black plastic handle. Tool designed for the quick and easy opening of paint cans without damaging them. Easy-to-clean.



**H-J SEE BELOW**  
**Aluminium Paint Measuring Sticks**  
 Ideal tool for measuring correct ratios as well as stirring. Double-side design. Stamped hole at top for convenient storage.

Model No:	Ratio:
<b>H PA04</b>	2:1/4:1
<b>I PA07 NEW</b>	1:1/3:1
<b>J PA08 NEW</b>	5:1/5:3

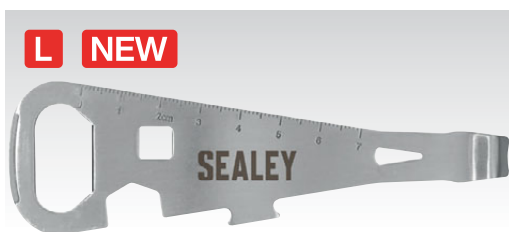

**L C071**  
**7-in-1 Paint Can Opener Multi-Tool**  
 Wide range of uses makes it perfect for decorators, builders and at home. Functions include: Can Opener, Bottle Opener, Ruler, Nail Puller, 8mm Nut Wrench, 13mm Hex Wrench, Screwdriver. High quality stainless steel won't rust or bend during normal use. Pocket sized lightweight design.



**K ARD01**  
**On-Gun Digital Pressure Regulator/Gauge**  
 On/off button with adjustable auto-off function for extended battery life. Small and compact with composite body. Pressure can be displayed in psi, bar, kg/cm<sup>2</sup> or KPa.

**Maximum Pressure:** 160psi/11bar/11.25kg/cm<sup>2</sup>/1100kPa  
**Maximum Flow:** 20cfm @ 100psi

**A**

Magnetic



**A MSH01**

**Magnetic Spray Gun Holder**

Heavy-duty magnet will adhere to any ferrous surface. 50mm Wide steel hook with protective rubber coating. Suitable for use with most gravity fed spray guns.

Magnet Capacity:	4.5kg
Hook Width:	50mm

**B**

Magnetic



**B MSH02**

**Magnetic Spray Gun Holder - 2 Gun**

Heavy-duty magnetic bracket with two large magnets, which will adhere to any ferrous surface. Composite covered magnets prevent scratching of surface. Suitable for storing up to two spray guns.

Size (W x H):	200 x 118mm
---------------	-------------

**B**



Tools not included.

**C**



**C SH03**

**Spray Gun & Filter Holder - 3 Gun**

Heavy-duty triple gun stand, constructed from steel with painted finish. 60mm Wide hooks make this suitable for use with most gravity feed spray guns. Features an adjustable filter ring to make pot filling simpler.

Size (W x H):	220 x 360mm
Hook Width:	60mm

**D**

Magnetic



**D MSH03**

**Magnetic Spray Gun Holder - 2 Gun**

Heavy-duty magnetic bracket with six large magnets which will adhere to any ferrous surface. Composite covered magnets and PVC bumper help prevent against damaging surface. Suitable for storing up to two spray guns.

Size (W x H):	200 x 120mm
---------------	-------------

**D**



Tools not included.

**E**

**F**



**E-F SEE BELOW**

**Paint Filters - Packs of 10**

In-line suction pot and gravity cup filters.

Model No:	Type:
<b>E</b> ILF/PF10	Suction Feed
<b>F</b> ILF/GF10	Gravity Feed

**G**

**G** ILF/SE

**In-Line Water Trap/Filter**

Compact unit, ideal for fitting directly onto air inlet.



**H**

**H** ILF/RG

**On-Gun Pressure Regulator/Gauge**

Maximum Pressure:	160psi
Maximum Flow:	18cfm @ 90psi

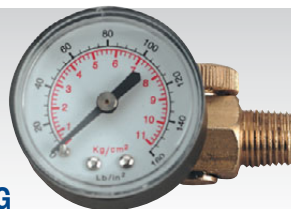

**I NEW**

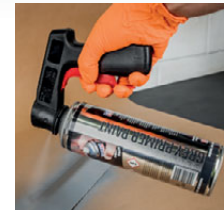

**I SCG01**

**Spray Can Trigger Handle**

Trigger handle grip design manufactured for comfort and ease of use. Universal fitment allows for use with multiple aerosol can cap types. Compact design made from a tough and durable plastic. Trigger on the handle allows for spray control.



A

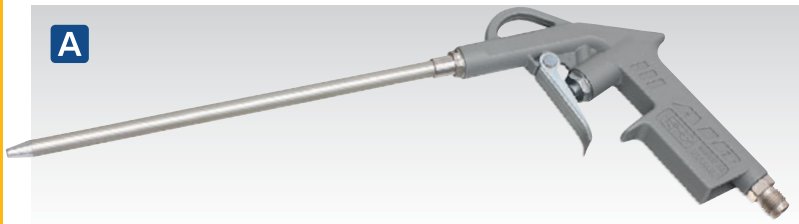

### A SA919 200mm Air Blow Gun

Die-cast metal body with moulded handle and hanging point. Maximum operating pressure 110psi.

Lance Length:	200mm
Inlet Size:	1/4" BSP

B



### B SA914 4pc Air Blow Gun

Composite valve body with interchangeable nozzles and safety tip. Includes 100 and 300mm extensions, gun body, blanking plug and safety nozzle. Maximum operating pressure 110psi.

Lance Length:	100/300mm
Inlet Size:	1/4" BSP

C



### C SA334 Air Blow Gun

Die-cast metal body with moulded handle and hanging point. Fitted with short type nozzle. Maximum operating pressure 110psi.

Inlet Size:	1/4" BSP
-------------	----------

D



### D SA304 Air Blow Gun

Die-cast metal body with moulded handle and hanging point. Fitted with short type nozzle. Supplied with quick release coupling. Maximum operating pressure 110psi.

Inlet Size:	1/4" BSP
-------------	----------

E NEW



### E SA904 Mini Air Blow Gun with Venturi Tip

Composite mini air blow gun with venturi tip for increased airflow compared to standard blow guns. Small size and detachable hook allow the blow gun to be ready to use at all times. Maximum working pressure of 90psi.

Inlet Size:	1/4" BSP
-------------	----------

F



G



Nozzle is fitted with six safety outlets.

### F-G SEE BELOW Air Blow Guns - Side Outlet

Trigger operated side outlet blow guns with extended lance. Suitable for the removal of dust and other particulates from air filters, radiators, condensers and other surfaces. Ideal for the commercial, agricultural and bodyshop environment. Lance allows projection of airflow directly to required area at a 90° angle to the body. Nozzle is fitted with six safety outlets. Maximum operating pressure 90psi.

Model No:	Lance Length:	Inlet Size:
F SA9247	715mm	1/4" BSP
G SA9248	1095mm	1/4" BSP

H NEW



I NEW



J NEW



### H-J SEE BELOW Air Blow Guns with 1/4" BSP Air Inlet

Trigger operated blow guns fitted with brass air inlet ferrule. Suitable for quick removal of chips, dust and particulate from any surface. Ideal for use in the workshop or bodyshop. Long lance allows projection of airflow directly to required area. Model No. SA9252 Air Curtain Nozzle is ideal for a larger dispersal of air. Air release valve built into the body enables the trigger/airflow to be feathered. Maximum operating pressure 140psi.

Model No:	Type:	Inlet Size:
H SA9250	110mm Lance	1/4" BSP
I SA9251	270mm Lance	1/4" BSP
J SA9252	Air Curtain Nozzle	1/4" BSP





**A SG139**  
**Air Operated Underbody Coating Gun**

Accepts most popular types of 1L coating tins.

Recommended Air Pressure:	90psi
Air Consumption:	10cfm
Air Inlet Size:	1/4" BSP



**B SG14**  
**Air Operated Underbody Coating Gun**

Accepts most popular types of 1L coating tins. Supplied with extended flexible nozzle for wax spraying cavities.

Recommended Air Pressure:	90psi
Air Consumption:	8cfm
Air Inlet Size:	1/4" BSP



**C AK42**  
**Air Operated Underbody Coating Gun**

Fitted with regulator to obtain even deposit of coating. Accepts most popular types of 1L coating tins.

Recommended Air Pressure:	90psi
Air Consumption:	5cfm
Air Inlet Size:	1/4" BSP



**D SG14D**  
**Underbody Coating/Wax Injector Kit with Disposable Heads**

Unique disposable head and pick-up tube assembly means that you never need to clean your gun again - just throw away the head and tube every time. Saves time and mess. Supplied with wax injector probe.

Recommended Air Pressure:	29-145psi
Air Consumption:	3.5-12.5cfm
Air Inlet Size:	1/4" BSPT
Replacement Head Kit:	SG14D/ACC Disposable Heads & Tubes (x6)



**E SG16**  
**Deluxe Air Operated Underbody Coating/Wax Injector Gun**

Features air control valve, making it suitable for various applications. Supplied with canister and wax injection probe.

Recommended Air Pressure:	60-115psi
Air Consumption:	10-13cfm
Air Inlet Size:	1/4" BSP

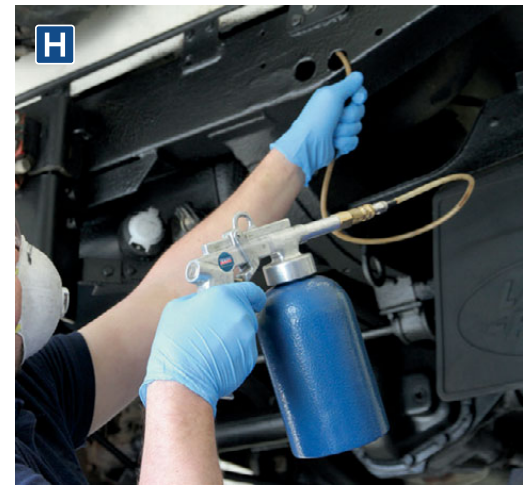

**F 9360/63**  
**Half Mask with ABEK1 P2R Filter Cartridges**  
For full details, see page 1289.



**G SG19**  
**Underseal Gun with Canister & Extension Probe**

Suitable for most brands of wax rust inhibitor. Supplied with nozzle for surface application and 910mm flexible probe for cavities.

Recommended Air Pressure:	87-145psi(6-10bar)
Air Consumption without Extension:	13.4cfm
Air Consumption with Extension:	6.4cfm
Air Inlet Size:	1/4" BSP



**H SG18**  
**Air Operated Wax Injector Kit**

Designed for the application of wax rust inhibitor. Supplied with a selection of lances to enable the wax to be sprayed into body cavities through small access points.

Recommended Air Pressure:	60-90psi
Air Consumption:	15cfm
Air Inlet Size:	1/4" BSP



**A AK39**  
**220mm Skeleton Type Manual Caulking Gun**

Suitable for 310ml cartridges up to 220mm length.

Cartridge Length:	220mm
Overall Length:	330mm



**D AK3901**  
**260mm Skeleton Type Manual Caulking Gun**

Suitable for 310-380ml cartridges up to 260mm length. Hook end suitable for attaching to user's belt.

Cartridge Length:	260mm
Overall Length:	370mm

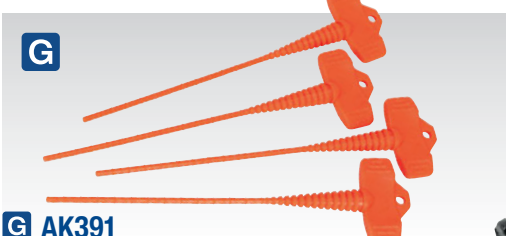

**G AK391**  
**Applicator Nozzle Stopper - Pack of 4**

Cut-to-size and insert into cartridge application nozzle. Airtight seal safeguards the sealant/adhesive from oxidization, reducing wastage.



**I AK4801**  
**220mm Heavy-Duty Caulking Gun**

Suitable for 310ml cartridges up to 220mm length. Includes tip cutter, just insert the nozzle of the cartridge and squeeze the handle. Tip piercer/cleaner for clearing sealant from dried nozzles. Hook end suitable for attaching to user's belt.

Cartridge Length:	220mm
Overall Length:	390mm



**B AK3801**  
**230mm Caulking Gun**

Die-cast body with aluminium tube. Supplied with plastic plunger and application nozzle. Suitable for 400ml sausage packs and 310ml cartridges.

Cartridge Length:	230mm
Overall Length:	340mm



**E AK3803**  
**330mm Caulking Gun**

Die-cast body with aluminium tube. Supplied with plastic plunger and application nozzles. Suitable for sausage packs and cartridges.

Cartridge Length:	330mm
Overall Length:	485mm



**H AK4803**  
**280mm Heavy-Duty Caulking Gun**

Suitable for 310ml and 380ml cartridges up to 280mm length. Includes tip cutter, just insert the nozzle of the cartridge and squeeze the handle. Tip piercer/cleaner for clearing sealant from dried nozzles. Hook end suitable for attaching to user's belt.

Cartridge Length:	280mm
Overall Length:	435mm



**J NEW**

**SV20**  
**SERIES**



**C AK41**  
**230mm Air Caulking Gun**

Accepts standard 310ml cartridges. Fitted with trigger control for smooth application of caulking.

Recommended Air Pressure:	36-43.5psi
Air Consumption:	3.5cfm
Air Inlet Size:	1/4" BSP
Cartridge Length:	230mm



**F AK4804**  
**220mm One-Hand Caulking Gun**

Suitable for 310ml cartridges up to 220mm in length. Able to handle higher viscosity materials. Trigger handle eliminates wrist strain when operating for extended periods of time. Single hand design allows the user to maintain three points of contact when using a ladder. Hook end suitable for attaching to user's belt.

Cartridge Length:	220mm
Overall Length:	330mm

**J-L SEE BELOW**  
**20V 310ml Cordless Caulking Gun**

Cordless 20V caulking gun with cartridge holder. 6-Speed variable setting optimises the flow rate aiding precision. Suitable for 310ml cartridges. Cordless operation allows the gun to be used anywhere in workshops and homes. Composite housing with soft grip for added comfort. Requires compatible 20V battery and mains charger, sold separately. For more information, see page 856.

Model No:	Contents:
<b>J</b> CP20VCG	Body Only
<b>K</b> CP20VCGKIT1	CP20VCG - Caulking Gun CP20VBP2 - 2Ah Battery CP20VMC - Battery Charger CP1200CB - Canvas Storage Bag
<b>L</b> CP20VCGKIT	CP20VCG - Caulking Gun CP20VBP2 - 2Ah Battery CP20VBP4 - 4Ah Battery CP20VMC - Battery Charger CP1200CB - Canvas Storage Bag





**A MK65**  
**Masking Paper Dispenser - 1 x 450mm Roll**  
 Single roll dispenser accepts rolls up to 450mm and can be used floor standing or wall mounted. Automatically applies adhesive tape to edges of masking paper.  
**Capacity:** 1 x 450mm Paper Roll  
**Note:** Papers and tapes not included with any dispenser/trolley



**B MK66**  
**Masking Paper Dispenser Trolley - 2 x 450mm Rolls**  
 Two roll dispenser accepts rolls up to 450mm. Features a side tray and larger storage tray underneath dispenser unit. Automatically applies adhesive tape to edges of masking paper.  
**Capacity:** 2 x 450mm Paper Rolls  
**Note:** Papers and tapes not included with any dispenser/trolley



**C MK67**  
**Masking Paper Dispenser Trolley - 2 x 900mm**  
 Two roll dispenser accepts rolls up to 900mm and features storage tray underneath dispenser unit. Automatically applies adhesive tape to edges of masking paper.  
**Capacity:** 2 x 900mm Paper Rolls  
**Note:** Papers and tapes not included with any dispenser/trolley



**D MK64**  
**Masking Paper Dispenser Step-Up - 1 x 450mm Roll**  
 Single roll dispenser accepts rolls up to 450mm. Features a step-up working platform. Automatically applies adhesive tape to edges of masking paper.  
**Capacity:** 1 x 450mm Paper Roll  
**Note:** Papers and tapes not included with any dispenser/trolley



**E MK77**  
**Polymask/Masking Paper Dispenser - 1 x 900mm Roll**  
 Single roll dispenser accepts 900mm rolls and can be used either horizontally or vertically. Durable lightweight design with wheels for easy manoeuvrability.  
**Capacity:** 1 x 900mm Roll  
**Note:** Papers and tapes not included with any dispenser/trolley



**F-G SEE BELOW**  
**General-Purpose Masking Tape**  
 Suitable for use up to 60°C.  

Model No:	Width:	Length:
<b>F</b> MTG24P	24mm	50m
<b>G</b> MTG48P	48mm	50m



**A-C SEE BELOW**

**Plunger Cans**

Easy one-handed operation, these plunger cans are convenient and safe for dispensing flammable solvents. Spring mounted dasher delivers a controlled amount of liquid to swab/cloth. Perforated metal flash arrestor protects against ignition and escape of flammable vapours.

Model No:	Capacity:
<b>A</b> PC1	1L
<b>B</b> PC19	1.9L
<b>C</b> PC38	3.8L

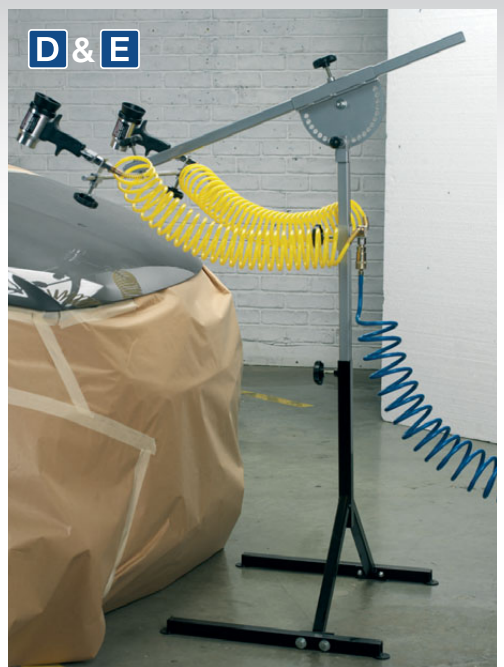

**D SDAST**

**Double Stand for Air Operated Panel Dryers**

Stand will support one or two air panel dryers (Model No's SDA01 or SDA03), allowing operator more time for other tasks. Fully adjustable for height and dryer angle. Supplied with coiled air hoses and fittings.

Minimum Height:	Ground Level
Maximum Height:	2300mm



**E SDA01**

**Air Operated Panel Dryer**

Designed for drying water based paints. Panel dryer operates on workshop air supply. Filter prevents airborne particles contaminating paint surface. Adjustable airflow to regulate as required. Ideal for localised or spot repair. May be handheld or mounted on optional Double Support Stand - Model No. SDAST **D**.

Air Inlet Size:	1/4"BSPT
Maximum Working Pressure:	90psi
Air Consumption:	10cfm @ 15psi, 18cfm @ 90psi



**F SDA03**

**Air Operated Panel Dryer with Adjustable Airflow**

Designed for drying water based paints. Lightweight, composite panel dryer operates on workshop air supply. Filter prevents airborne particles contaminating paint surface. Adjustable airflow to regulate as required. Ideal for localised or spot repair. May be handheld or mounted on optional Double Support Stand - Model No. SDAST **D** (requires Model No. SA1/1414 - 1/4"BSPT Male to Male Adaptor [x2], see page 793).

Air Inlet Size:	1/4"BSPT
Maximum Working Pressure:	90psi
Air Consumption:	7cfm @ 40psi, 15cfm @ 90psi



**G BS101**

**Upholstery/Body Cleaning Gun**

Designed for the car dealer and professional valet, this essential tool cleans hard-to-reach areas such as seat runners, door trims, dashboards, upholstery and bodywork. Tornado action lifts dirt out of upholstery.

Air Inlet Size:	1/4"BSPT
Air Pressure:	101-116psi(7-8bar)
Air Consumption:	6.35cfm

**A**



Electronic Control Panel.



**3000W**  
**SHORT WAVE**  
**230V**

**B**



**B MK78**

**Paint Dirt Removal Pen with Needle Set**

For full details, see page 698.



**A IR3000**

**3000W Infrared Panel Dryer - Short Wave**

Three 1000W high output short wave lamps in three individually switched cassettes. Lamps emit short wave infrared heat ideal for optimising drying of water based paints. This flexible system allows each cassette to be adjusted and locked in position around the contours of the vehicle, ensuring maximum area coverage. Height adjustment is made using the locking gas strut, offering near weightless movement of the cassette support arm. Supplied with 5m power cable.

Number of Elements:	Element Power:	Reflector Size:	Supply:	Plug Type:	Power Supply Cable Length:
3	1000W	490 x 140mm	230V	Bare Wire	5m

**C NEW**

**Premier**

**HVLP**



**C HVLP05**

**Professional HVLP Gravity Feed Spray Gun 1.3mm Set-Up**

Gravity feed spray gun designed for applying clear and base coats. Features air and paint flow controls for fine adjustment of spray pattern with a maximum size of 280mm. HVLP technology and precision engineering delivers consistent and unrivalled results. No rubber O-ring design for solvent resistance and increased life. Stainless steel fluid passages, needle, nozzle, air cap and air valve suitable for solvent and water based paints.

<b>Standard Set-Up:</b>	1.3mm
<b>Available Set-Ups:</b>	1.2, 1.4mm
<b>Recommended Air Pressure:</b>	29-32psi
<b>Air Consumption:</b>	14.12cfm
<b>Pot Capacity:</b>	600ml

**D NEW**

**1000W**

**230V**



**D IR1000S**

**1000W Infrared Panel Dryer - Short Wave**

Designed and developed to assist with any number of small drying processes. Ideal for spot repairs, engine drying, adhesive stripe removal, drying filler, drying primer or just preheating prior to spraying. Supplied with a sturdy 2100mm plated steel stand and a 3m power cable and 3-pin plug.

<b>Reflector Size:</b>	300 x 110mm
<b>Supply:</b>	230V
<b>Plug Type:</b>	3-Pin
<b>Power Supply Cable Length:</b>	3m

**E**



**E AP95**

**Airbag Cabinet**

Mandatory safe storage for airbag and seat belt pre-tensioner charges. This cabinet is made from 2mm thick sheet steel and is fitted with a quality slam type lock. Keeps charges safe from theft or tampering. Can be wall mounted.

<b>Size (H x W x D):</b>	614 x 457 x 307mm
--------------------------	-------------------



**A** Extendable**A** VS0140**1.2m Telescopic Bonnet/Tailgate Support**

Three tier telescopic aluminium tailgate/bonnet support with tough rubber pads at each end. Lock in any position with a simple twist. Also suitable for holding open doors, depressing clutch, brake or accelerator pedals.

**Length:** 242-1200mm

**B** NEW**B** MK80**1.95m Adjustable Paint Hanger**

Adjustable height from 1.3m to 1.95m. Six hooks with a combined capacity of 75kg for hanging small parts. Suitable for hanging bumpers, bonnets, doors, wings and spoilers. Fitted with four castors, two with brakes for maximum manoeuvrability and safe positioning.

<b>Maximum Capacity:</b>	75kg
<b>Minimum Height:</b>	1300mm
<b>Maximum Height:</b>	1950mm

**C****C** RE55**4-Level Bumper Rack**

Double-sided rack for safe and tidy workshop storage of most vehicle bumpers. Heavy-duty construction ideal for use in bodyshops. Four pairs of height-adjustable support arms for maximum capacity and flexibility. Fitted with four castors, two with brake, for manoeuvrability and safe positioning.

<b>Width:</b>	1170mm
<b>Height:</b>	2180mm
<b>Arm Length:</b>	520mm
<b>Safe Working Load:</b>	160kg

**D****D** MK56**Wall Mounting Folding Bumper Rack**

Suitable for holding up to three bumpers of various lengths for tidy workshop storage. Arms mountable in nine positions fold safely away when not in use, so saving space.

<b>Support Height:</b>	750mm
<b>Arm Length:</b>	640mm
<b>Safe Working Load:</b>	80kg

**F****F** MK61**Spray Booth Stand**

Ideal for holding small vehicle body parts such as grilles, spoilers, wings and mirror housings during preparation and spraying.

<b>Height:</b>	1105mm
<b>Width:</b>	850mm

**E****E** MK50**Folding Panel Stand**

Versatile stand suitable for a wide variety of workshop and bodyshop applications. Work height is fully adjustable by lengthening chains. Foam-cushioned supports help prevent marking of panel.

<b>Width:</b>	1000mm
---------------	--------

**G****G** MK54**Folding Bumper/Panel Stand**

Ideal for storage of bumpers prior to preparation and spraying. Adjustable stand width with extendable arms makes this unit suitable for holding various types and styles of bumpers. Folds away for easy storage.

<b>Width Arms Closed:</b>	700mm
<b>Width Arms Fully Extended:</b>	2000mm
<b>Folded Height:</b>	1130mm

**A MK76**  
**Mobile Panel Storage Rack Holds 5 Panels**

Suitable for windscreens, sheet metals, bonnets and doors as well as other large items. Store up to five panels with a maximum capacity of 150kg. Rack includes 12 foam-cushioned support arms to protect the items held within it. Fitted with four castors, two with brakes, for maximum manoeuvrability and safe positioning.

Arm Length:	630mm
Width:	700mm
Height:	635mm
Maximum Capacity:	150kg



**100kg Capacity**

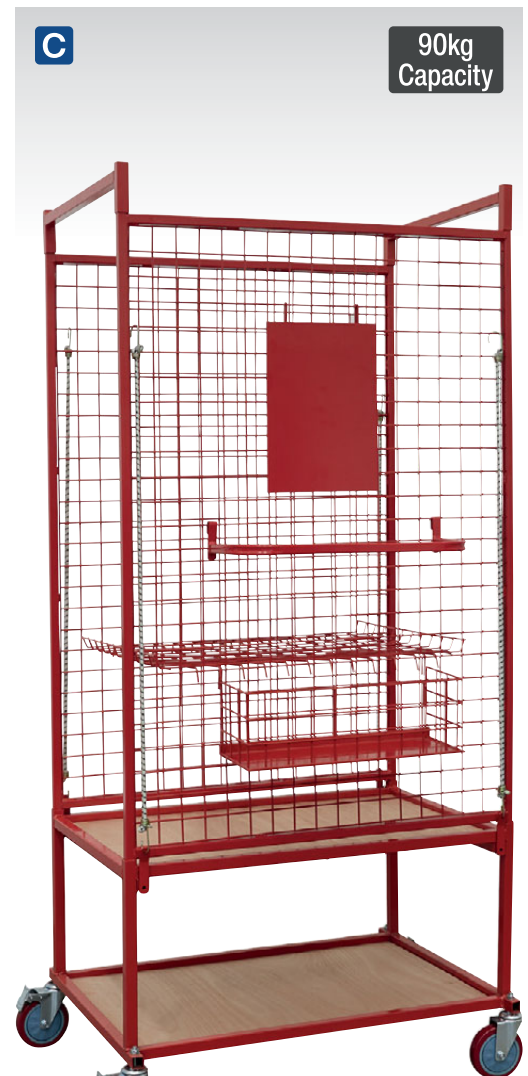
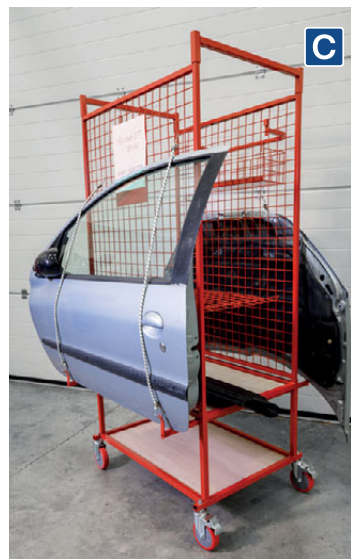
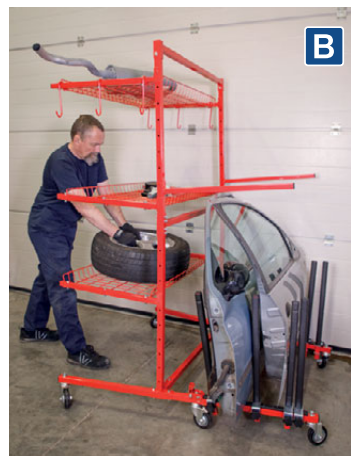

**90kg Capacity**

**B MK75**  
**Parts Cart with Panel Train**

Suitable for use with windscreens, sheet metal, bonnets and doors as well as other large items. Panel train includes eight foam-cushioned support arms to protect the items held within it. Fitted with four castors, two with brakes, for maximum manoeuvrability and safe positioning. Also includes Shelves (x3), 600mm Arms (x2), S-Shaped Hooks (x6).

Shelf Dimensions (W x D):	940 x 550mm
Overall Dimensions (W x D x H):	1400 x 800 x 1870mm
Maximum Capacity:	100kg

**D PST01**  
**2pc Panel Gap Setting Tool**

Panel gap setting tool with 10 plastic gauges and a suction cup for damage-free mounting and use. Each gauge is 1mm thick with alternating shades for easy selection. Ideal for use on panels gaps and windscreen mounting to ensure even gaps. Range of 1-10mm.



**D NEW**

**C MK70**  
**Car Parts Trolley**

Heavy-duty parts trolley for organized storage of car parts during repair. Equipped with hanging rack for bumpers and exhaust pipes. Also includes a parts shelf, writing board, small parts basket and elastic straps for securing larger items. Fully manoeuvrable on four castor wheels, two with brakes.

Size (W x D x H):	890 x 590 x 1700mm
Maximum Capacity:	90kg





50kg  
Capacity

### A MK72 Alloy Wheel Painting/Repair Stand Single Wheel Capacity

Fully adjustable supporting bars and cones for optimum height. Cone is angled for ease of use. Holds wheel up to 22". Supplied with 100mm PU wheels for moving the stand around the workshop or spray booth. Rotates the wheels on the cones so that each wheel can be painted completely.

Size (W x D x H): 800 x 800 x 1000mm  
Maximum Capacity: 50kg



### C MK71 Alloy Wheel Painting/Repair Stand 4 Wheel Capacity

Fully adjustable supporting bars and cones for optimum height. Cones are angled for ease of use. Holds four wheels. Supplied with 100mm PU wheels for moving the stand around the workshop or spray booth. Suitable for use on spray booth floors. Rotates the wheels on the cones so that each wheel can be painted completely.

Size (W x D x H): 1200 x 1200 x 1000mm  
Maximum Capacity: 80kg



### B MK74 Alloy Wheel Repair/Painting Stand 4 Wheel Capacity

Will take four alloy wheels and enable the user to rotate the wheels on cones so the wheels can be repaired or painted without the need to lift and reposition them. Both supporting bars and cones have adjustable heights in order to provide the most comfortable position for the user. Fitted with four castors, two with brakes for maximum manoeuvrability and safe positioning.

Overall Length: 1285mm  
Maximum Capacity: 100kg



60kg  
Capacity

### D MK73 Universal Mobile Rotating Panel Stand

Ideal for doors, bonnets, bumpers, wings and spoilers. Adjustable and rotating bars make this stand suitable for almost all panel types. Portable for easy manoeuvring of application from preparation to spray booth. Includes S-hooks (x2), spray gun holder, vertical supports with fixed hooks (x4), supports with holes (x2).

Overall Length: 1240mm  
Short Adjustable Bar Length: 400mm  
Long Adjustable Bar Length: 700mm  
Height Without Bars: 950mm  
Maximum Capacity: 60kg



90kg  
Capacity

### E MK62 Rotating Universal Panel Stand

Suitable for supporting multiple panels and trims including wings, bumpers and spoilers. Eight adjustable bars and 360° rotation make this stand suitable for almost any panel types. Portable for easy manoeuvring of application from preparation to spray booth.

Overall Length: 1600mm  
Short Adjustable Bar (x4): 450mm  
Long Adjustable Bar (x4): 750mm  
Height (Without Bars): 1070mm  
Maximum Capacity: 90kg



**40kg Capacity**

**A MK79**  
**Rotating Panel Repair Stand**

Compact design but handles the larger bonnets, tailgates etc. Ideal for doors, bonnets, bumpers, wings and spoilers. Fully adjustable, rotates full 180°. Adjustable and rotating bars make this stand suitable for almost all panel types. Portable for easy manoeuvring of application from preparation to spray booth.

Overall Arm Width:	1550mm
Base Dimensions (W x D):	900 x 710mm
Maximum Capacity:	40kg



**40kg Capacity**

**B MK51**  
**Panel Stand - Door, Wing, Bonnet & Bumper**

Features fully adjustable arms to fit many styles of bonnets, wings, doors and bumpers. Main frame can adjust through 180° to give required angle. Fitted with two fixed Ø180mm wheels and two braked Ø100mm castors for manoeuvrability.

Overall Arm Width:	890mm
Base Dimensions (W x D):	980 x 700mm
Maximum Capacity:	40kg



**C**

**HEAVY DUTY**

**C MK59**  
**Heavy-Duty Panel Stand - Door, Wing, Bonnet & Bumper**

Suitable for supporting large panels from cars or commercial vehicles. Features fully adjustable arms to fit many styles of bonnets, wings, doors, bumpers and tailgates. Each level can rotate 360° to suit. Fitted with two fixed Ø180mm wheels and two braked castors for manoeuvrability.

Maximum Arm Length:	1430mm
Maximum Height:	1600mm
Base Dimensions (W x D):	1150 x 700mm



**D**

**D WK4**  
**Folding Windscreen Stand**

Lightweight tubular steel design with variable height facility. Large rubber suckers prevent screen from moving during preparation. Folding frame makes this ideal for both workshop and mobile screen preparation.

Width:	1000mm
Folded Height:	1200mm



### A **Generation**



SA50 without Needle Scaler.  
To use as a standard air hammer order Spring Retainer (SA11R/17).

#### A SA50

##### Air Needle Scaler - Pistol Type

Generation series pistol type scaler suitable for cleaning heavy paint and rust scale from metal surfaces. Removable needle head allows use as a standard air hammer but requires additional chisel set and spring retainer (not included). Features variable speed trigger control. Spring retainer, needle and chisel sets available separately.

Stroke:	43mm
No-Load Speed:	4500bpm
Air Consumption:	4cfm
Operating Pressure:	90psi
Inlet Size:	1/4"BSP
Weight:	1.98kg
Noise Power/Pressure:	111/100dB(A)
Vibration/Uncertainty:	13/5.2m/s <sup>2</sup>
Replacement Needle Set (19pc):	SA50.02
Optional Spring Retainer:	SA11R/17

### D



Dust-Free  
Ø150mm

#### D SA09

##### Ø150mm Dust-Free Air Palm Orbital Sander

Polycarbonate outer housing with soft rubber handgrip reduces chill and vibration. Fitted with dual bearings in eccentric assembly to maximize working life. Exhaust muffler helps reduce noise emission. Dust-free outlet for use with centralised dust extraction systems. Supplied with Ø150mm hook-and-loop pad.

Pad Size:	Ø150mm
No-Load Speed:	10000rpm
Orbit Size:	Ø5mm
Air Consumption:	13cfm
Operating Pressure:	90psi
Inlet Size:	1/4"BSP
Vacuum Outlet:	Ø28mm
Weight:	1kg
Noise Power/Pressure:	92/81dB(A)
Vibration/Uncertainty:	5.7/0.54m/s <sup>2</sup>

### B



Polisher

Ø75mm

**Generation**

#### B GSA722

##### Ø75mm Air Polisher

Textured grip and lightweight aluminium alloy housing provide comfort and control. Powerful air motor provides smooth operation under load. Supplied with Ø75mm hook-and-loop pad and spanner. Use with Ø79mm buffing and polishing heads.

Pad Size:	Ø75mm
Thread Size:	M6 x 1mm
No-Load Speed:	2500rpm
Air Consumption:	4cfm
Operating Pressure:	90psi
Inlet Size:	1/4"BSP
Weight:	0.7kg
Noise Power/Pressure:	94/83dB(A)
Vibration/Uncertainty:	4.13/0.90m/s <sup>2</sup>

### E

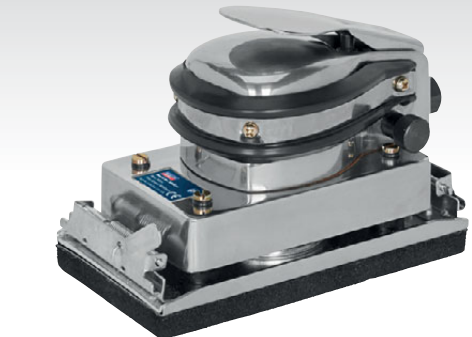

165 x 90mm

#### E SA22

##### Air Operated Flat Bed Sander

Orbital flat bed sander with counter-balanced drive shaft for smooth operation. Palm type trigger with rubber head ring allows comfortable, one-handed operation. Suitable for sanding body panels, wood, metals and plastics, this tool is suitable for 115mm roll papers and uses strong spring clips to attach them to the base plate.

Pad Size:	165 x 90mm
Orbit Size:	Ø5mm
No-Load Speed:	8000rpm
Air Consumption:	13cfm
Operating Pressure:	90psi
Inlet Size:	1/4"BSP
Weight:	1.88kg
Noise Power/Pressure:	93/82dB(A)
Vibration/Uncertainty:	16.5/6.6m/s <sup>2</sup>

### C



35L

Dust-Free

Wet & Dry

**Generation**



#### C DFSK01

##### Dust-Free Sanding Kit

Refer to individual Model No's for full specification.

##### Package Includes:

**DFS35M** - 35L Dust-Free Wet & Dry Industrial Vacuum Cleaner Plastic Drum M-Class Filtration Self-Clean

**GSA05** - Ø150mm Dust-Free Air Palm Random Orbital Sander

**RE4011** - 70 x 120mm Dust-Free Sanding Block

**RE4012** - 70 x 198mm Dust-Free Sanding Block

### F

**NEW**

Dust-Free

Wet & Dry



#### F DFSK02

##### Dust-Free Sanding Kit

Refer to individual Model No's for full specification.

##### Package Includes:

**PC35230V** - 35L Wet & Dry Industrial Vacuum Cleaner Plastic Drum M-Class Filtration Self-Clean & Auto-Start

**DAS150PS** - Ø150mm Variable Speed Brushless Electric Palm Sander 350W/230V

**RE4011** - 70 x 120mm Dust-Free Sanding Block

**RE4012** - 70 x 198mm Dust-Free Sanding Block



**A OS400**

**Ø150mm Random Orbital Electric Sander 400W**

Ø5mm Orbit designed specifically for use on car body repairs. 6-Stage variable speed control from 4000-10000rpm. Ergonomic rubberised gear head casing for added comfort and grip during use. Fitted with 5m mains cable. Supplied with Ø150mm hook-and-loop backing pad, spare brushes and hex key.

Motor Power:	400W
Supply:	230V
No-Load Speed:	4000-10000rpm
Thread Size:	M8
Orbit Size:	Ø5mm
Pad Size:	Ø150mm



**B OS600**

**Ø150mm Random Orbital Electric Sander 600W**

Ø9mm Orbit designed specifically for use on car body repairs. 6-Stage variable speed control from 3200-7200rpm. Ergonomic rubberised gear head casing for added comfort and grip during use. Fitted with 5m mains cable. Supplied with Ø150mm hook-and-loop backing pad, side handle, spare brushes and hex key.

Motor Power:	600W
Supply:	230V
No-Load Speed:	3200-7200rpm
Thread Size:	M8
Orbit Size:	Ø9mm
Pad Size:	Ø150mm



**C OP750**

**Ø150mm Orbital Polisher 750W**

Ø21mm Orbit specifically designed for use in the bodyshop. 6-Stage variable speed control ranging from 2000-4500rpm. Vibration reducing motor and rubberised gear head cover allow for greater comfort and reduce user fatigue. Soft start for greater control. Speed stabilizer to ensure constant speed output. Fitted with 5m mains cable. Supplied with Ø150mm backing pad, two Ø180mm foam polishing pads, side handle, wrench and spare brushes.

Motor Power:	750W
Supply:	230V
No-Load Speed:	2000-4500rpm
Thread Size:	M8
Orbit Size:	Ø21mm
Pad Size:	Ø150mm



**D RP1500**

**Ø150mm Rotary Polisher 1050W**

Powerful 1050W motor enclosed in a heavy-duty composite housing. 6-Stage variable speed control from 700-2500rpm. Soft start for greater control. Vibration reducing motor to allow for longer working times with reduced fatigue. Spindle lock for fast and easy pad changes. Double-torque gearing system. Fitted with 5m mains cable. Supplied with Ø150mm backing pad, side handle, wrench and spare brushes.

Motor Power:	1050W
Supply:	230V
No-Load Speed:	700-2500rpm
Thread Size:	M14
Pad Size:	Ø150mm



**E SPK600**

**Spot Polisher Kit 600W**

Rotary spot polisher kit with ergonomic slim body design. 6-Stage variable speed control from 700-2500rpm. Spindle lock for easy pad and shaft changes. Soft start for greater control. Fitted with 5m mains cable. Supplied with a selection of polishing pads, side handle and spare brushes.

Motor Power:	600W
Supply:	230V
No-Load Speed:	700-2500rpm
Thread Size:	M14
Pad Size:	Ø25-75mm
Cable Length:	5m
Weight:	2.58kg



A

30W



Premier

B SDL14.M

Stainless Steel Wire Mesh  
Pack of 2

Suitable for plastic repair.

B



C SEE BELOW

Plastic Welding Rods  
Packs of 5

Suitable for Model No. SDL14 Plastic Welder.

Model No:	Description:
SDL14.ABS	ABS Plastic Welding Rods
SDL14.PP	PP Plastic Welding Rods
SDL14.PPF	PP Flat Plastic Welding Rods
SDL14.PE	PE Plastic Welding Rods
SDL14.PS	PS Plastic Welding Rods

C



A SDL14

## 30W Lithium-ion Rechargeable Plastic Welding Repair Kit

Cordless and lightweight welding iron. Inbuilt LED to illuminate welding area in low light areas such as engine bays. Kit includes plastic welding tip, plastic welding with pipe guide tip, hot staple tip, plastic welding rods in ABS/PP/PE/PS, reinforcing mesh (x3), 0.8mm flat staples (x50), 0.6mm flat staples (x50), USB charging lead and safety stand. Heats up to a maximum temperature of 500°C.

Battery:	3.7V 2.4Ah Lithium-ion
Charging Time:	3.5hr
Maximum Temperature:	500°C
Operating Time:	40min
Power:	30W

D

NEW

230V

75W

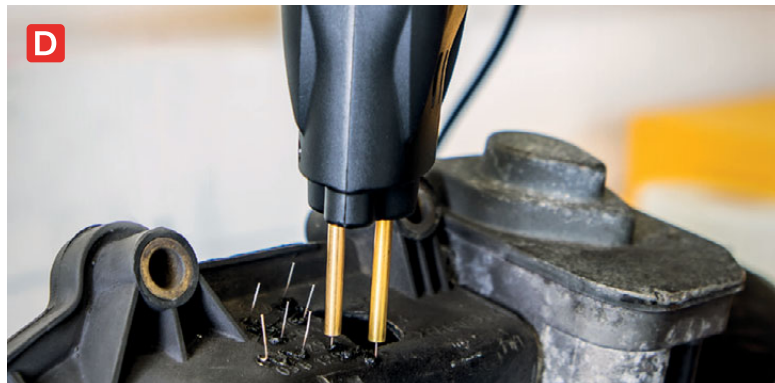

D SDL15

## 75W Plastic Welding Repair Kit

Heat gun body is lightweight and easy to operate with maximum control and accuracy provided by pistol grip design. Repairs cracked plastic parts such as car bumpers. Three different heat modes, high/medium/low. Overheating/overload protection. High brightness LED light to illuminate work area. Kit comprises of staples; 0.6mm outside corner (x50), 0.8mm inside corner (x50), 0.6mm flat (x50), 0.8mm flat (x50), 0.6mm wave (x50), 0.8mm wave (x50), soldering iron tip (x1), heat gun (x1).

Supply:	230V ~ 50Hz
Plug Type:	3-Pin
Power Supply Cable Length:	2m
Power:	75W
Maximum Temperature:	700°C
Cable Length:	1.93m
Staple Size:	0.6mm & 0.8mm
Duty Cycle:	15s on/10s off
Weight:	0.80kg

E

F

G

NEW

H

NEW

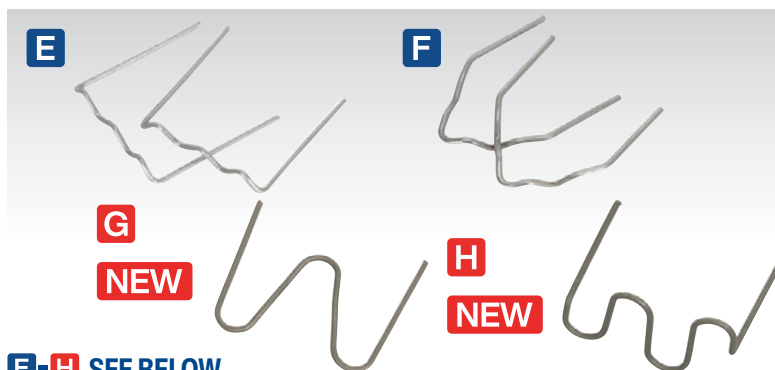

E-H SEE BELOW

## Replacement Staples for SDL14 &amp; SDL15

Staples for Model No's SDL14 and SDL15.

Model No:	Type:	Size:	Quantity:
E RE06	Flat	0.6mm	100
F RE06V	Inside Corner	0.6mm	100
G RE06C	Outside Corner	0.6mm	100
H RE06W	Wave	0.6mm	100
E RE08	Flat	0.8mm	100
F RE08V	Inside Corner	0.8mm	100
H RE08W	Wave	0.8mm	100

I NEW

I SDL15.01

## Soldering Iron Tip For SDL15

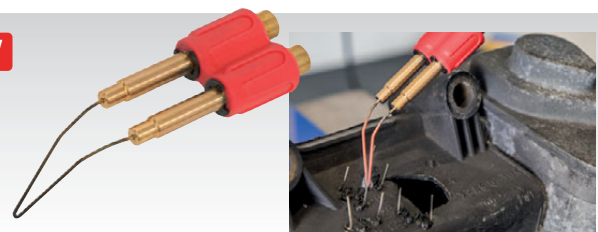



**A 3015CXD**

**3 Tonne Trolley Jack with Super Rocket Lift**

Single-piece hydraulic unit with heavy base design and large jacking saddle. Twin piston Super Rocket Lift feature brings lifting arm straight into contact with the jacking point in 1-2 strokes. Universal joint release mechanism allows safer, more controlled lowering of the jack. Fitted with safety overload valve and pump-through valve to prevent handle locking at maximum ram extension. For full specification, see page 279.

**D WS570**

**570kg Wheel Skate**

Steel chassis with pedal operated mechanical lifting action. Skate sits on easy-rolling Ø100mm nylon castor wheels. Composite rollers cradle vehicle's tyre and are capable of handling up to 240mm profiles. Suitable for bodyshops, garages, showrooms or anywhere an immobile vehicle needs moving on an even surface.

Note: Skates sold as singles, but must be used in pairs.

Capacity:	570kg
Maximum Opening:	620mm
Maximum Tyre Profile:	240mm
Castor Diameter:	Ø100mm
Weight:	17.5kg



**E WS650**

**650kg Hydraulic Wheel Skate**

Steel chassis with PVC rollers and four Ø100mm nylon castors. Pedal operated hydraulic lifting action with safety locking pin when under load. Rollers cradle vehicle's tyre and are capable of handling up to 270mm profiles. Suitable for bodyshops, garages, showrooms or anywhere an immobile vehicle needs moving on an even surface. Note: Skates sold as singles, but must be used in pairs.

Capacity:	650kg
Maximum Opening:	550mm
Maximum Tyre Profile:	270mm
Castor Diameter:	Ø100mm
Weight:	17kg



**B WS454**

**454kg Wheel Dolly Set**

Pressed steel wheel dolly with four Ø90mm metal castors. Can handle up to 355mm profiles. Suitable for use in bodyshops and workshops.

Capacity Each:	454kg
Maximum Tyre Profile:	355mm
Castor Diameter:	Ø90mm
Weight Each:	9kg



**F WS680**

**680kg Hydraulic Wheel Skate**

Steel tube chassis with four Ø100mm nylon castors. Pedal operated hydraulic lifting action with safety locking pin when under load. Aluminium rollers cradle vehicle's tyre and are capable of handling up to 240mm profiles. Suitable for bodyshops, garages, showrooms or anywhere an immobile vehicle needs moving on an even surface. Note: Skates sold as singles, but must be used in pairs.

Capacity:	680kg
Maximum Opening:	540mm
Maximum Tyre Profile:	240mm
Castor Diameter:	Ø100mm
Weight:	17kg



**C WS681**

**680kg Wheel Dolly Set**

Heavy-duty steel-plate with rust resistant finish. Fitted with four Ø75mm metal castors, two lockable. Each dolly features a side handle for easy carrying. Can handle up to 250mm profiles. Suitable for use in bodyshops and workshops.

Capacity Each:	680kg
Maximum Tyre Profile:	250mm
Castor Diameter:	Ø75mm
Weight Each:	7.6kg



**G VS858**

**Folding Mechanic's Work Mat**

Flexible work mat with two handles for portability. Durable composite cover that resists stains and fluids. High-density padding for added comfort. Ideal for working on cold garage floors and for roadside repairs.

Folded (L x W x D):	610 x 444 x 76mm
Unfolded (L x W x D):	1220 x 444 x 38mm





2 Tonne

**A RE901****2 Tonne Adjustable Transportacar Trolley**

Heavy-duty steel frame suitable for supporting partly dismantled or badly damaged vehicles. Enables easy movement around bodyshop. The supports are interchangeable between V-crutches and sill clamps. Supports and clamps adjustable for height and overall width. Fitted with four Ø125mm nylon castors, two of which lock.

<b>Using with Crutches:</b>	
Minimum Height:	250mm
Maximum Height:	310mm
<b>Using with Sill Clamps:</b>	
Minimum Height:	330mm
Maximum Height:	390mm
Minimum Width*:	1035mm
Maximum Width*:	1430mm
Capacity:	2 Tonne
Closed Length:	600mm

\*Widths measured between centres of jacking points

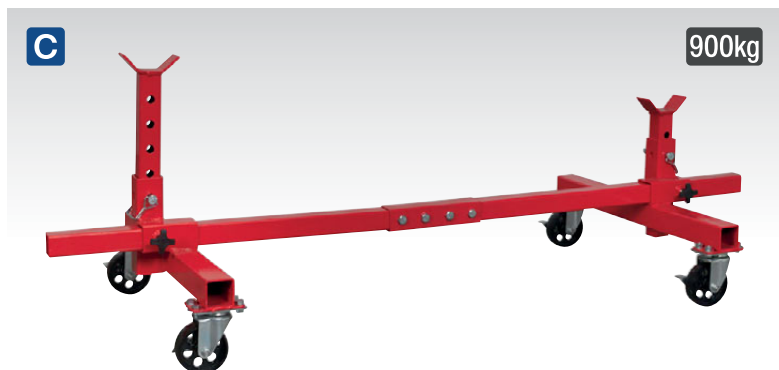

900kg

**C VMD001****900kg Adjustable 2-Post Vehicle Moving Dolly**

Heavy-duty steel frame suitable for supporting partly dismantled or badly damaged vehicles. Enables easy movement around workshop or bodyshop. Crutch supports adjustable for height and overall width. Fitted with four Ø90mm locking metal castors.

Minimum/Maximum Height:	315/495mm
Increments:	4 x 45mm
Minimum Support Width:	350mm
Maximum Support Width:	1450mm
Width:	1500mm
Capacity:	900kg

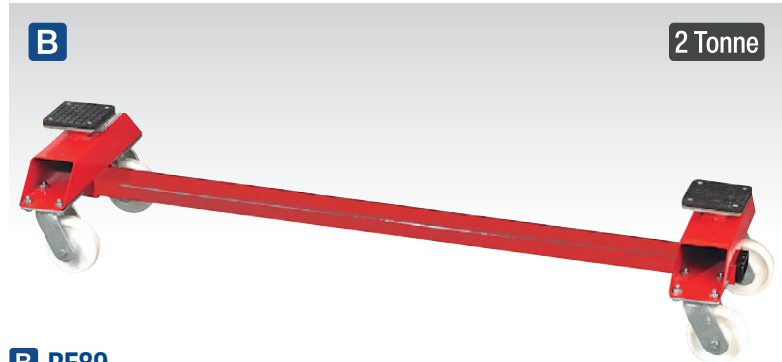

2 Tonne

**B RE89****2 Tonne Adjustable Transportacar Trolley - Economy Model**

Steel frame designed for supporting and moving partly dismantled or badly damaged vehicles around the workshop or bodyshop. Sliding castor brackets adjust for width and rubber-faced support pads adjust for height.

Minimum/Maximum Height:	300/390mm
Maximum Width:	1485mm
Capacity:	2 Tonne
Castor Diameter:	Ø150mm



D

900kg

**D VMD002****900kg Adjustable 4-Post Vehicle Moving Dolly**

Heavy-duty steel frame suitable for supporting partly dismantled or badly damaged vehicles. Enables easy movement around workshop or bodyshop. Adjustable frame allows you to change the length and width as required. Three types of height-adjustable and interchangeable supports, rubber support pads, shallow and deep crutches. Fitted with four Ø200mm nylon locking castors.

Minimum Height:	400mm
Maximum Height:	520mm
Minimum Width:	680mm
Maximum Width:	1280mm
Minimum Length:	1150mm
Maximum Length:	1750mm
Capacity:	900kg



**A RE92/11**  
**Large Hook Pull Kit**  
 Suitable for reaching over wide obstructions. Ideal for inside boot recesses. Reduces marking due to chains. Supplied with two sizes of feet and adaptor for SuperSnap® screw-on accessories and heads.  
**Capacity:** 6 Tonne



**B RE92/12**  
**90° Dual Pull Clamp**  
 Suitable for use with bodyshop repair kits and chassis straighteners.  
**Capacity:** 4 Tonne



**C RE91/5/CK**  
**Chain Kit 2 x 2m Chains - 2 Clamps**  
 Use in conjunction with Model No. RE91/05 Pull Ram. The kit contains 2 x 2m chains each with one hook and two heavy-duty pull clamps.



**D SAR01**  
**Wheel Arch Reshaping Tool**  
 Reshaping tool designed for repairing wheel arch collision damage or for increasing tyre-to-wing clearance by flaring wheel arches. Fully adjustable telescopic arm that allows 180° wheel swivel. Elongated holes on the hub adaptor plate suitable for vehicles with various four and five stud/bolt patterns. Bolts directly to the hub assembly. Attached hitch pin allows for change in angle.  
**Min./Max. Arm Length:** 440/560mm

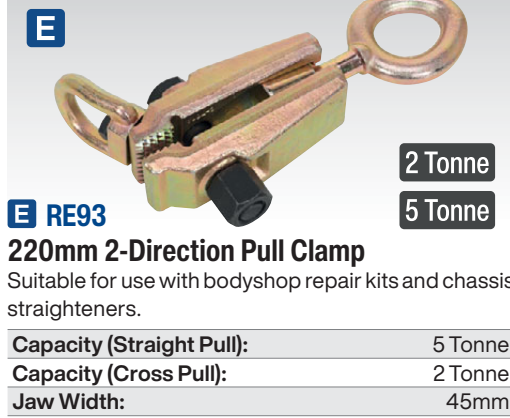

**E RE93**  
**220mm 2-Direction Pull Clamp**  
 Suitable for use with bodyshop repair kits and chassis straighteners.  
**Capacity (Straight Pull):** 5 Tonne  
**Capacity (Cross Pull):** 2 Tonne  
**Jaw Width:** 45mm

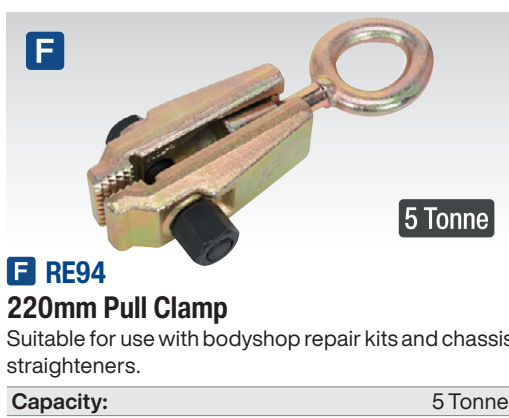

**F RE94**  
**220mm Pull Clamp**  
 Suitable for use with bodyshop repair kits and chassis straighteners.  
**Capacity:** 5 Tonne  
**Jaw Width:** 45mm

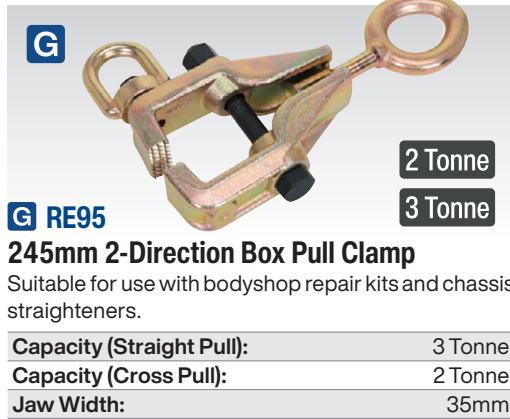

**G RE95**  
**245mm 2-Direction Box Pull Clamp**  
 Suitable for use with bodyshop repair kits and chassis straighteners.  
**Capacity (Straight Pull):** 3 Tonne  
**Capacity (Cross Pull):** 2 Tonne  
**Jaw Width:** 35mm

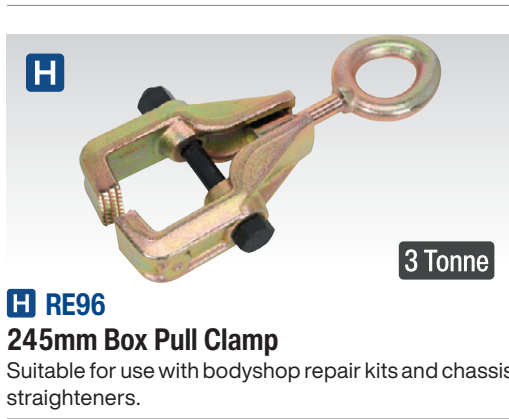

**H RE96**  
**245mm Box Pull Clamp**  
 Suitable for use with bodyshop repair kits and chassis straighteners.  
**Capacity:** 3 Tonne  
**Jaw Width:** 35mm



**I DR66**  
**Door Restraining Bars - Pack of 2**  
 Manufactured with steel tube and heavy jaw assemblies. Designed to triangulate and strengthen door apertures whilst performing pulling operations. Supplied with tommy bar.  
**Minimum Length:** 830mm  
**Maximum Length:** 1160mm  
**Jaw Width:** 90mm



**J RE99/10**  
**1.5 Tonne Wheel Arch Puller Short Pattern**  
 Suitable for wheel arches and other small/lightweight pulls including those around light clusters.  
**Capacity:** 1.5 Tonne  
**Length:** 160mm





**A-B SEE BELOW**

**Pull Rams**

Spring-return pull rams, suitable for use with manual or air powered hydraulic pumps. Supplied with two chain hooks.

	<b>A</b>	<b>B</b>
Model No:	RE91/05	RE91/10
Capacity:	5 Tonne	10 Tonne
Closed/Open Height:	530/660mm	350/500mm
Return Spring:	✓	✓



**C-D SEE BELOW**

**Pull Rams**

Suitable for many applications including workshop, agricultural, industrial, and construction where pulling, positioning, bending and holding of heavy loads may be required. Use in conjunction with manual or air powered hydraulic pumps.

	<b>C</b>	<b>D</b>
Model No:	RE97XM02	RE97XM05
Capacity:	2 Tonne	5 Tonne
Closed/Open Height:	422/550mm	520/650mm
Return Spring:	✓	✓



**E 2 Tonne**

**E RE97XM02.H-F**

**Hook (Female Thread) for RE97XM02**

2 Tonne hook (Female Thread) for Model No. RE97XM02.



**F**

**F RE97.10-A13**

**Wedge Ram**

500kg Capacity wedge ram for prying damaged body panels apart from one another. Use in conjunction with manual or air powered hydraulic pumps.



**G-K SEE BELOW**

**Push Rams**

Suitable for many applications including workshop, agricultural, industrial, and construction where lifting, pushing, positioning, bending and holding of heavy loads may be required. Use in conjunction with manual or air powered hydraulic pumps.

	<b>G</b>	<b>H</b>	<b>I</b>	<b>J</b>	<b>K</b>
Model No:	RE97XC02	RE97XC10	RE97XM04	RE97XM10	610/41
Capacity:	2 Tonne	10 Tonne	4 Tonne	10 Tonne	10 Tonne
Closed/Open Height:	139/240mm	132/189mm	275/405mm	350/500mm	305/465mm
Return Spring:	✗	✓	✓	✓	✓



**L SEE BELOW**

**SuperSnap® Tube Extensions & Adaptors**

Extension tubes and adaptors for Model No. RE97/10 (see page 718) and other hydraulic body repair kits.

Model No:	Type:	Size:
610/A2	Extension	560mm
610/A3	Extension	480mm
610/A4	Extension	280mm
610/A5	Tube Adaptor	125mm
610/A6	Tube Adaptor	75mm



**M RE97.10-COMBO**

**10 Tonne Snap Push Ram with Pump & Hose Assembly**

Package Includes:	Description:
Model No:	
RE97.10-02	10 Tonne Ram Assembly
RE97.10-01	10 Tonne Pump & Hose Assembly



**N 610/45**

**10 Tonne SuperSnap® Push Ram with Pump & Hose Assembly**

Package Includes:	Description:
Model No:	
RE97.10-03	Hose Assembly
610/41	10 Tonne Push Ram
610/40	10 Tonne Hydraulic Pump



**A-E SEE BELOW**  
**Short Push Rams**

Extremely short closed height makes these rams suitable for use where there is almost no clearance at the lift point. Suitable for use with Sealey Hydraulic Repair Kits and other brands.

	<b>A</b>	<b>B</b>	<b>C</b>	<b>D</b>	<b>E</b>
<b>Model No:</b>	RE97XC04	RE97XS05	RE97XS10	RE97XS20	RE97XS30
<b>Type:</b>	Push Ram	Push Ram	Push Ram	Push Ram	Push Ram
<b>Capacity:</b>	4 Tonne	5 Tonne	10 Tonne	20 Tonne	30 Tonne
<b>Closed/Open Height:</b>	42/58mm	33/39mm	43/54mm	52/63mm	59/71mm



**F-G SEE BELOW**  
**10 Tonne Pump & Hose Assemblies**

Suitable for use with most leading brand hydraulic ram repair kits.

	<b>F</b>	<b>G</b>
<b>Model No:</b>	610/40	RE97.10-01
<b>Capacity:</b>	10 Tonne	10 Tonne
<b>Outlet Thread:</b>	1/4" BSP	1/4" BSP



**H RE97.10-03**  
**Hose Assembly**

Hose assembly for use with Sealey Body Repair Kits and Model No. TC966 Hydraulic Bead Breaker.

<b>Inlet Thread:</b>	1/4" BSPT
<b>Length:</b>	1540mm



**Hydraulic**

**I RE97XCKIT**  
**Specialist Push & Pull Ram Set**

Comprehensive set of mini, midi and maxi sized push and pull rams. Suitable for many applications including workshop, agricultural, industrial and construction where lifting, pushing, positioning, bending and holding of heavy loads may be required. Supplied in steel storage case.

**Set features:**

- ✓ High flow quick connecting couplers with dust caps on all components.
- ✓ Unique ram and cylinder bearings absorb eccentric load stresses in order to protect the cylinder against abrasion, over-extension and jamming.
- ✓ Chromed rams with polyurethane seals and wipers provide longer service life.
- ✓ Selected rams fitted with heavy-duty return spring.

**Contents:**

Ram Model No:	Capacity/Type:	Closed Open/Height:	Return Spring:
RE97XC02	2 Tonne/ Push Ram	139/240mm	✗
RE97XC04	4 Tonne/ Push Ram	42/58mm	✗
RE97XM04	4 Tonne/ Push Ram	275/405mm	✓
RE97XC10	10 Tonne/ Push Ram	132/189mm	✓
RE97XM10	10 Tonne/ Push Ram	350/500mm	✓
RE97XM02	2 Tonne/Pull Ram	422/550mm	✓
RE97XM05	5 Tonne/Pull Ram	520/650mm	✓

Hooks Model No:	Type:	Application:
RE97XM02.H-F	Female	RE97XM02
RE97XM02.H-M	Male	RE97XM02
RE97XM05.H-F	Female	RE97XM05
RE97XM05.H-M	Male	RE97XM05



**A RE97/4****4 Tonne Snap Hydraulic Body Repair Kit**

Heavy gauge snap-together pipework and cast snap-together attachments compatible with most leading makes of snap-together equipment. Supplied with hand operated pump, hose, hydraulic ram and storage case.

**B RE83/4****4 Tonne SuperSnap® Hydraulic Body Repair Kit**

SuperSnap® kits feature snap-together pipework for speed, and threaded attachments for strength. Connecting parts are zinc or cad plated for long, rust-free life. Components are manufactured from high quality steel and finished with red supergloss paint. All attachments interchange with other popular makes so you can use your existing equipment with the SuperSnap® range. Supplied in composite storage case.

**C RE97/10****10 Tonne Snap Hydraulic Body Repair Kit**

Heavy gauge snap-together pipework and cast snap-together attachments compatible with most leading makes of snap-together equipment. Supplied with 10 Tonne hand operated pump, hose, hydraulic ram and storage case.

**D RE83/10****10 Tonne SuperSnap® Hydraulic Body Repair Kit**

SuperSnap® kits feature snap-together pipework for speed, and threaded attachments for strength. Connecting parts are zinc or cad plated for long, rust-free life. Components are manufactured from high quality steel and finished with red supergloss paint. All attachments interchange with other popular makes so you can use your existing equipment with the SuperSnap® range. Supplied in composite storage case.

**E RE9720****20 Tonne Snap Body Repair Kit**

Heavy gauge snap-together pipework and snap-together attachments compatible with most leading makes of snap-together equipment. Supplied with 20 Tonne hand operated pump, hose, hydraulic ram and metal storage case.

**F****AIR Hydraulic****F SEE BELOW****10 Tonne Air Hydraulic Pumps**

Suitable for use with SuperSnap® hydraulic ram as supplied with Model No. DZRE21 Body Straightener and all body repair kits. Supplied with or without air hose.

Model No:	Specification:
RE83/840	Air Pump Only
RE83/840/CWH	Air Pump with Hose
Maximum Air Input:	90-120psi
Oil Capacity:	450cc
Oil Pressure:	10000psi

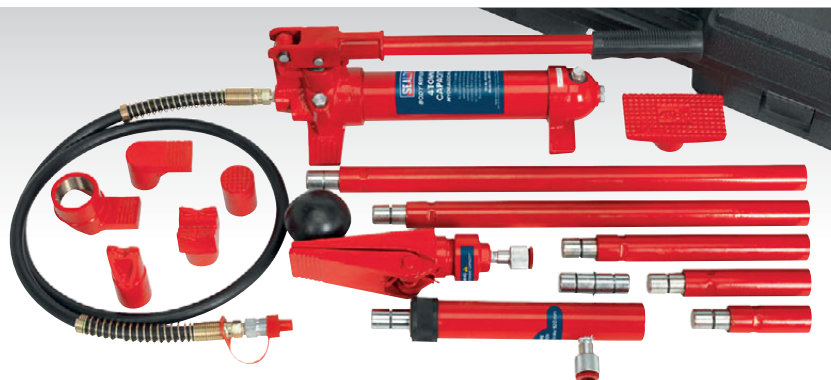
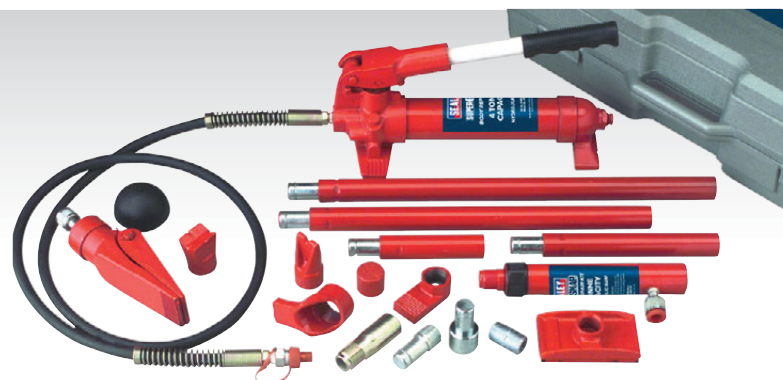
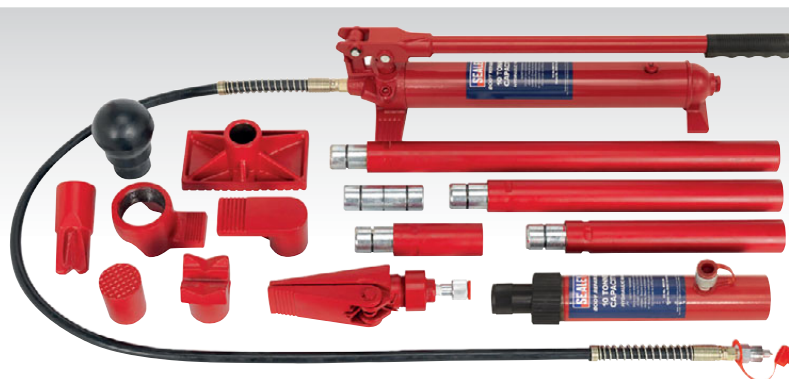
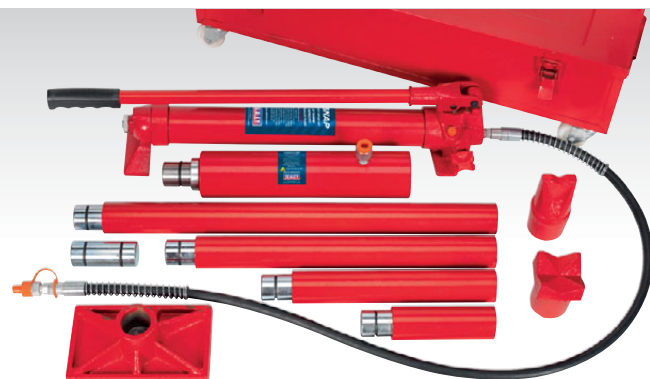
**A****4 Tonne****Snap****Hydraulic****B****4 Tonne****SUPER SNAP®****Hydraulic****C****10 Tonne****Snap****Hydraulic****D****10 Tonne****SUPER SNAP®****Hydraulic****E****20 Tonne****Snap****Hydraulic**



**A**

**Premier**

**HVL P**



**A HVL P01 Professional HVL P Gravity Feed Spray Gun 1.3mm Set-Up**

For full details, see page 694.



**B**

**B TA090 Paint Thickness Gauge**

For the professional bodyshop or valeting bay to accurately verify the thickness of paint and check for accident damage. Uses magnetic induction to provide accurate and consistent readings to 0.1µm. Suitable for steel and aluminium panels. Easy to calibrate with test plates and precision standards. USB Interface for downloading data to PC. Powered by 2 x 1.5V batteries (supplied).



**C**

**C TA091 Paint Thickness Gauge**

Ideal for the showroom, bodyshop and valeting bay to accurately verify the thickness of paint and check for accident damage. Uses magnetic induction to provide accurate and consistent readings to 0.1mm. Suitable for iron, steel and aluminium with non-magnetic coatings including paint, enamel, plastic and epoxy. Displays measurement in mm. Powered by CR2032 3V battery (supplied).

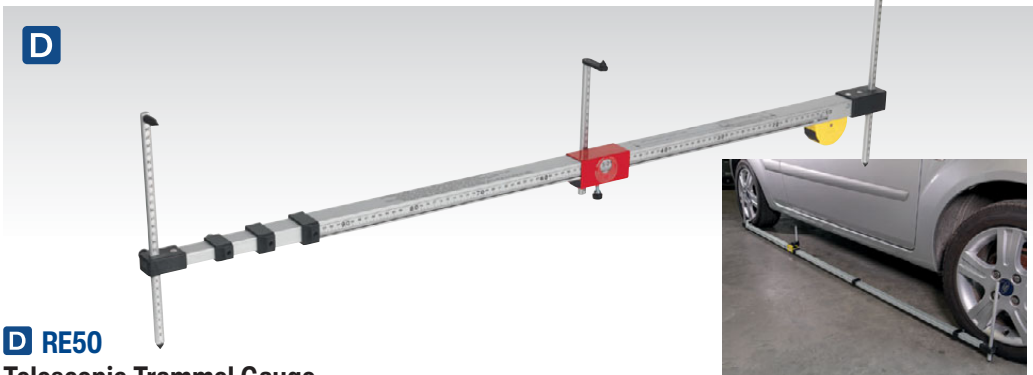

**D**

**D RE50 Telescopic Trammel Gauge**

Aluminium measuring device constructed in 4-sections. Suitable for obtaining precise dimensional data for chassis alignment purposes. Integral measuring tape provides fast metric read-out between end probes. Mid probe read-out obtained by markings on exterior of pole. Includes three fully adjustable probes.

Minimum Distance - End Probes:	1050mm
Maximum Distance - End Probes:	3000mm
Minimum Distance - Mid/End Probes:	170mm
Maximum Distance - Mid/End Probes:	730mm



**D**



**E**

- 10 Tonne
- Variable Tilt
- Hydraulic
- Super Pull
- 75+ KG
- HEAVY ITEM

**E DZRE21 Straightener Kit with Variable Upright**

Heavy-duty repair kit for straightening bent chassis and body damage. Variable position upright allows six preset angles of pull plus a seventh upright position. Supplied as standard with manual hydraulic pump and ram.

**Contains:** Chassis Frame, SuperSnap® Hydraulic Pump & Ram, Pull Clamp (x2), Sill Clamp (x2), Chain (x2), Chain Hook (x2), Carriage Anchorage Tube, Tube Stand (x2)



A-B

1 Shelf



(Model No. FSC04 &amp; FSC04ST illustrated).

C-D

A-B SEE BELOW

**Hazardous Substance Cabinets**

Sturdy metal construction with yellow powder coat. Supplied with a pack of appropriate warning labels. Single door, fitted with 2-point key lock and supplied with two keys. Features an adjustable, lipped shelf and liquid-tight base to retain spills. Smaller compact design for limited space.

<b>A Model No:</b>	<b>FSC06</b>
<b>Overall Size (W x D x H):</b>	350 x 300 x 705mm
<b>Shelves:</b>	1
<b>B Model No:</b>	<b>FSC04</b>
<b>Overall Size (W x D x H):</b>	460 x 460 x 900mm
<b>Shelves:</b>	1

C-D SEE BELOW

**Floor Stands for FSC06 & FSC04**

Sturdy metal stands to support Model No. FSC06 & FSC04.

<b>C Model No:</b>	<b>FSC06ST</b>
<b>Overall Size (W x D x H):</b>	350 x 300 x 580mm
<b>D Model No:</b>	<b>FSC04ST</b>
<b>Overall Size (W x D x H):</b>	460 x 460 x 580mm

Hazardous Substance Cabinets  
For our full range, see pages  
1002 to 1004.



H HCC08

**2.2 Tonne Pneumatic Paint Can Crusher**

Reduce your waste disposal costs\* - crushing paint cans minimizes the volume of your hazardous waste. Air operated paint can press with safety lock-out device which prevents the door being opened during operation. Bench mounting unit with outlet for waste paint collection.

\* For 'pay by volume' customers.

<b>Internal Size (W x D x H):</b>	280 x 230 x 250mm
<b>External Size (W x D x H):</b>	390 x 250 x 750mm
<b>Air Supply:</b>	100-130psi
<b>Air Inlet Size:</b>	1/4" BSP
<b>Weight:</b>	44kg

E

1 Shelf



F



E FSC05

**Hazardous Substance Cabinet**

Sturdy metal construction with yellow powder coat. Supplied with a pack of appropriate warning labels. Two door, fitted with 2-point key lock and supplied with two keys. Features an adjustable, lipped shelf and liquid-tight base to retain spills. Illustrated with optional floor stand, Model No. FSC05ST.

<b>Overall Size (W x D x H):</b>	900 x 460 x 900mm
<b>Shelves:</b>	1

F FSC05ST

**Floor Stand for FSC05**

Sturdy metal stand to support Model No. FSC05.

<b>Overall Size (W x D x H):</b>	900 x 460 x 445mm
----------------------------------	-------------------

G

3 Shelves



G FSC03

**Hazardous Substance Cabinet**

Sturdy metal construction with yellow powder coat. Supplied with a pack of appropriate warning labels. Two door, fitted with 2-point key lock and supplied with two keys. Features three adjustable, lipped shelves and liquid-tight base to retain spills. 155mm Raised, leak-proof door sill.

<b>Overall Size (W x D x H):</b>	900 x 460 x 1800mm
<b>Shelves:</b>	3
<b>Weight:</b>	59.74kg

H

2.2 Tonne

AIR Operated





**A-C SEE BELOW**

**150 x 230mm Abrasive Finishing Pads  
Packs of 10**

Versatile, long lasting hand pads. Flexible for contoured work surfaces to provide an even finish. Waterproof and solvent resistant. Can be cut-to-size. Supplied in packs of 10.

Model No:	Colour/Grade:	Applications:
<b>A</b> HP1523F	Green/Fine	General-Purpose
<b>B</b> HP1523M	Maroon/Medium	Prior to Primer
<b>C</b> HP1523UF	Grey/Ultra-Fine	Prior to Clear Coat



**F SB66**

**70 x 130mm Sanding Block**

Accepts 100mm wide abrasive strips. Comfortable contoured grip. Interlocking grip and base separate completely for very simple and fast abrasive changes.

Size:	70 x 130mm
-------	------------



**I-L SEE BELOW**

**Rigid Scrapers**

Chrome plated, highly polished steel blade with composite handle and hanging hole.

Model No:	Blade Width:	Length:
<b>I</b> AK5220	40mm	195mm
<b>J</b> AK5221	50mm	195mm
<b>K</b> AK5222	75mm	195mm
<b>L</b> AK5223	100mm	195mm



**D SPG01**

**Contour Gauge with Lock**

Profile gauge for use when comparing a damaged panel to the original or for duplication of profile when preparing bodywork. Features lock to secure pins when comparing panel shape. Pins made from non-scratch PS plastic. Suitable for use on various flooring, tiling and metalwork.

Maximum Profile Depth:	30mm
Maximum Profile Length:	250mm



**G SB65**

**65 x 120mm Sanding Block**

Accepts 100mm wide abrasive strips. Comfortable contoured grip. Abrasive firmly retained by integral pins.

Size:	65 x 120mm
Type:	Pinned Fixings



**M AK5225**

**3pc Body Filler Applicator Set**

Manufactured from composite material. Suitable for the application of body filler.

Blade Widths:	100, 125, 150mm
---------------	-----------------

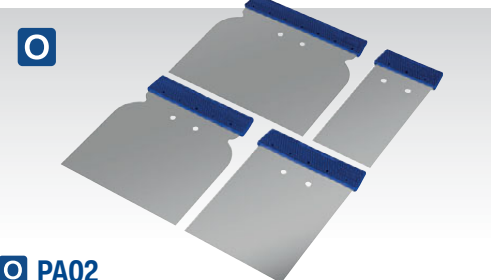

**O PA02**

**4pc Body Filler Applicator Set**

Manufactured from stainless steel. Suitable for the application of body filler.

Blade Widths:	50, 80, 100, 120mm
Length:	100mm



**E RE4011**

**70 x 120mm Dust-Free Sanding Block**

Hook-and-loop fitting on foam backing plate. Durable plastic body with soft grip incorporating a Ø20mm outlet for connection to an extraction system. Suitable for use with popular dust-free sanding sheets.

Outlet Diameter:	Ø20mm
Size:	70 x 120mm



**H RE4012**

**70 x 198mm Dust-Free Sanding Block**

Hook-and-loop fitting on foam backing plate. Durable plastic body with soft grip incorporating a Ø20mm outlet for connection to an extraction system. Suitable for use with popular dust-free sanding sheets.

Outlet Diameter:	Ø20mm
Size:	70 x 198mm



**N PA03**

**Plastic Filler Spreader  
Pack of 25**

Manufactured from composite material. Suitable for the application of body filler.

Blade Width:	105mm
Length:	70mm



**P PA06**

**Plastic Filler Spreader - Pack of 100**

Manufactured from composite material. Suitable for the application of body fillers, fibreglass filler, putty or caulking agents.

Blade Width:	105mm
Length:	70mm

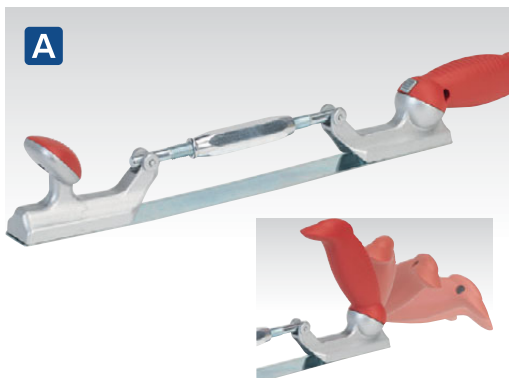

**A RE5001****Professional Adjustable Hand File Holder**

Simple screw adjustment flexes file either concave or convex to suit the job in hand. Features a 2-position swivel lock handle. Suitable for use in professional bodyshops. N.B. File not included - Order Model No's RE5001.9TPI or RE5001.12TPI.

**Optional Accessories:** RE5001.9TPI - 9tpi  
RE5001.12TPI - 12tpi

**B-C SEE BELOW****Hook-and-Loop Sanding Blocks**

Resilient sanding blocks for both small and large work areas. Both models have a hook-and-loop surface for attaching abrasive.

Model No:	Type:	Size:
<b>B RE4001</b>	Curved Hook-and-Loop	Ø150mm
<b>C RE4002</b>	2-Handed Hook-and-Loop	75 x 440mm

**D RE4019****90 x 135mm Sanding Block Flexible Tear Drop**

Flexible tear drop shaped sanding block. Designed for sanding various shapes, smaller surfaces and tight angles.

**Size:** 90 x 135mm

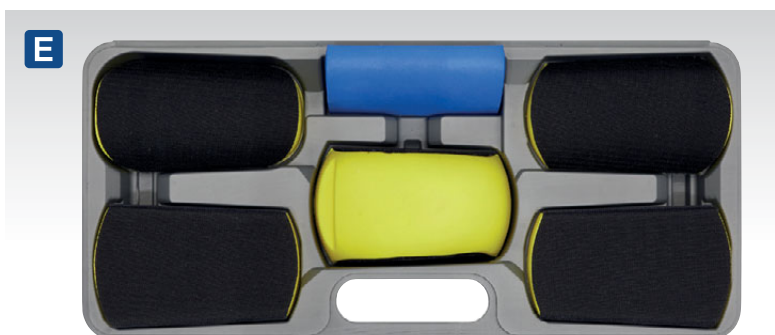
**E RE40KIT****6pc Hook-and-Loop Sanding Block Kit**

Comprehensive kit of resilient, rectangle style concave and convex sanding blocks with hook-and-loop surfaces and a flexible tear drop sanding block.

**Sizes:** Sanding Blocks; **RE4015** - Concave 90 x 155mm, **RE4016** - Convex 85 x 155mm, **RE4017** - Convex 90 x 160mm, **RE4019** - Flexible Tear Drop 90 x 135mm, **RE4020** - Concave 90 x 155mm, **RE4022** - Convex 90 x 150mm

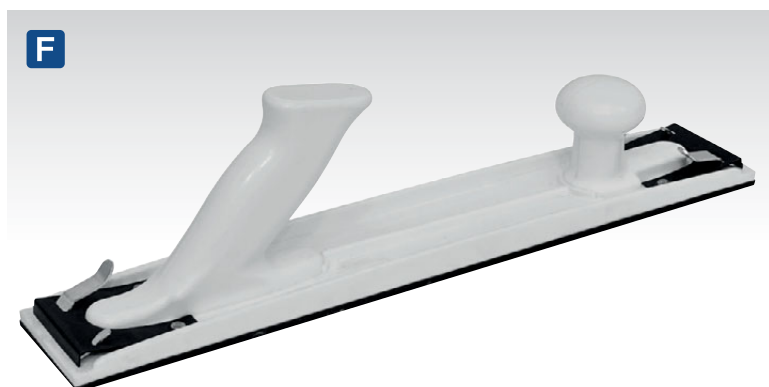
**F RE4021****70 x 407mm Long Board Hook-and-Loop Sanding Block**

Resilient, long board sanding block with 70 x 407mm hook-and-loop surface. Designed for larger areas such as bonnets and flat panels. Can also be used with clip-on sanding sheets.

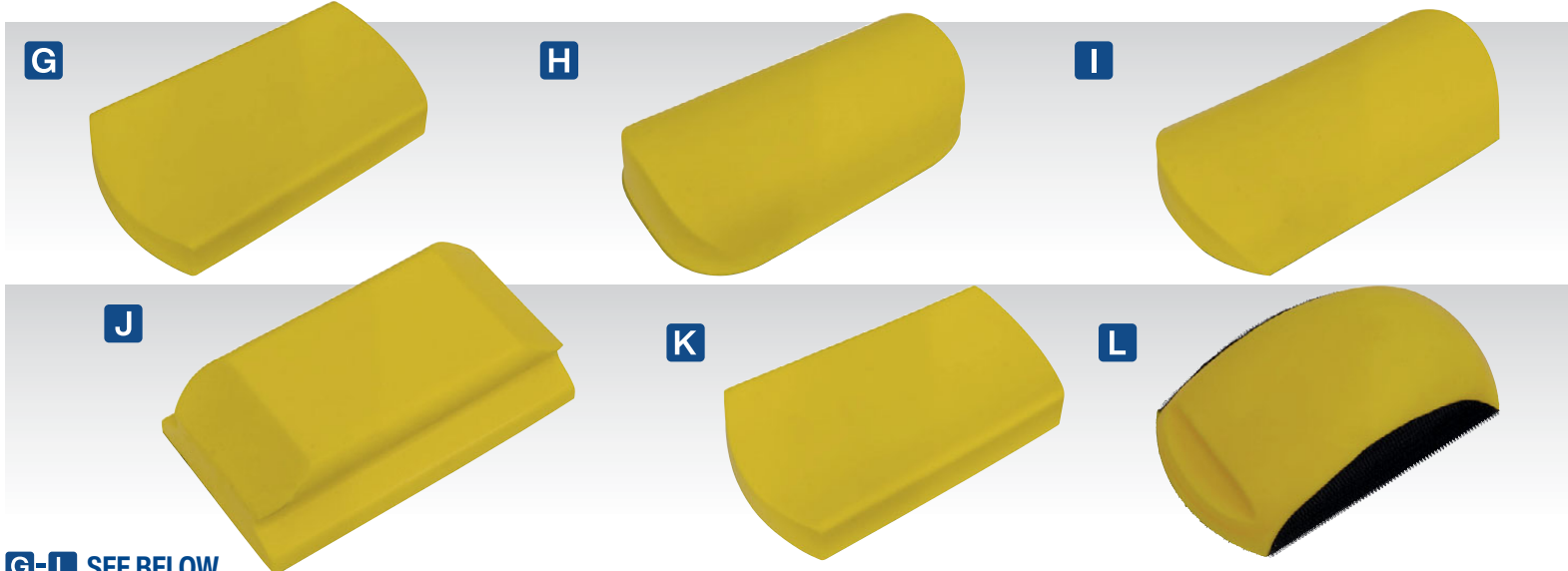
**G-L SEE BELOW****Hook-and-Loop Shaped Sanding Blocks**

Range of resilient, shaped sanding blocks for both small and large work areas. All models have a hook-and-loop surface for attaching abrasive.

Model No:	<b>G</b>	<b>H</b>	<b>I</b>	<b>J</b>	<b>K</b>	<b>L</b>
<b>RE4015</b>	<b>RE4015</b>	<b>RE4016</b>	<b>RE4017</b>	<b>RE4018</b>	<b>RE4020</b>	<b>RE4022</b>
<b>Size:</b>	90 x 155mm	85 x 155mm	90 x 160mm	125 x 70mm	90 x 155mm	90 x 150mm

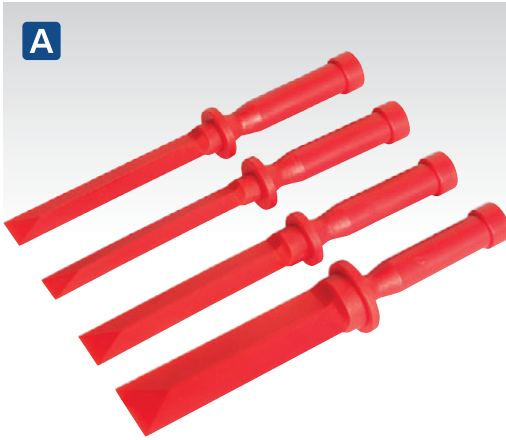

**A AK5251**  
**4pc Composite Scraper Set**

Ideal for removing trim, badges and decals from bodywork. Also suitable for removing residue from alloy wheels. Polypropylene edges will not scratch/mark paint or panel work and can be resharpened with a file when required.

Length:	265mm
Blade Widths:	19, 22, 25, 37mm



**D AK5960**  
**Underbody Inspection Mirror**

Adjustable handle and mirror head provides effortless functionality. Ideal for inspection of vehicle's underside.

Mirror Diameter:	Ø200mm
Minimum/Maximum Length:	660/1090mm

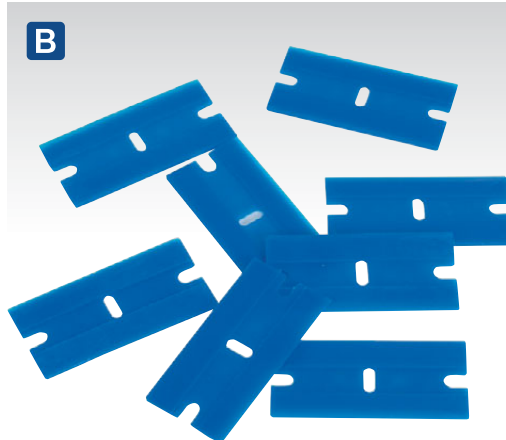

**B AK5228**  
**Composite Razor Blade - Pack of 100**

Pack of 100 composite razor blades. Suitable for use with Blade Holder, Model No. AK5227 **C**.

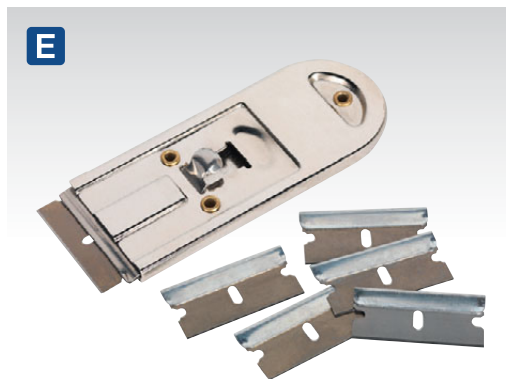

**E AK867**  
**Retracting Razor Scraper with Blades**

Chrome plated steel construction with retracting blade carrier for extra safety. Supplied with five spare blades.

Length:	100mm
Replacement Razor Blades:	AK867/1 (Pack of 5)



**G S0948**  
**52 x 83mm Telescopic Inspection Mirror with 2 LED Lights**

5-Section stainless steel inspection tool. 52 x 83mm Mirror with built-in LEDs mounted on twin ball joints for maximum articulation. Ideal for use in low light areas. Contoured and textured comfort grip handle. Supplied with batteries.

Lengths:	285-876mm
Battery:	2 x CR2032 (Supplied)



**C AK5227**  
**Composite Razor Blade Holder - Pack of 5**

Manufactured from composite material. Suitable for holding plastic or metal razor blades. Supplied in pack of five. Ideal for use with Sealey Composite Razor Blades, Model No. AK5228 **B**.

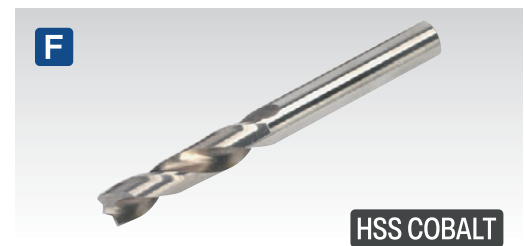

**F AK4734**  
**Ø8mm HSS Cobalt Spot Weld Drill Bit**

Suitable for drilling out spot welds on most common vehicle panels including galvanized and high stress steels. Made from HSS with 5% Cobalt for longer life.

Size:	Ø8mm
Length:	80mm



**H TA090**  
**Paint Thickness Gauge**

For the professional bodyshop or valeting bay to accurately verify the thickness of paint and check for accident damage. Uses magnetic induction to provide accurate and consistent readings to 0.1µm. Suitable for steel and aluminium panels. Easy to calibrate with test plates and precision standards. USB Interface for downloading data to PC. Powered by 2 x 1.5V batteries (supplied).







230V



### A SR2000 Stud Welding Kit

Professional quality stud welder for fast, efficient body repairs. Removes dents quickly, without holes or the need to remove interior trim. No burn through means that removal of studs and washers is easy and preparation work before repainting is minimized. Suitable for use on steel or aluminium and can weld studs, washers and tabs. Patented quick puller attachment allows removal of smaller dents without the need for studs or washers. Supplied in heavy-duty storage case.

<b>Contents:</b>	Welding Gun, Power Unit, Quick Puller, Electrodes for Welding, Washers; Round (x10), Triangle (x10), 55 x 22mm Tabs (x10), M4 x 15 Studs (x10), M4 Puller Washer, Earth Bars; 70mm (x2), 155mm
<b>Supply:</b>	230V
<b>Plug Type:</b>	3-Pin
<b>Power Supply Cable Length:</b>	2.6m
<b>Mains Fuse:</b>	13A
<b>Maximum Short Circuit Current:</b>	5000A
<b>Voltage Range:</b>	18V AC Output 24V DC, 32V AC Output 44V DC, 18V AC Output 24V DC
<b>Weight of Gun:</b>	2.25kg

### K SR20 Stud Welder with Slide Hammer

A welder of exceptionally quality for fast, efficient body repairs. Removes dents quickly, without holes or the need to remove interior trim. Amazing pulling power - even on heavier gauge panels. Welds on washers and nails. Supplied in heavy-duty storage case.

<b>Contents:</b>	Welding Gun, Slide Hammer, Electrodes for Welding, Nails; 2mm (x200), 2.5mm (x200), Washers; Ø16mm (x50), Washer Hook & Washer Extension Electrode, Heavy-Duty Case
<b>Supply:</b>	230V
<b>Plug Type:</b>	Bare Wire
<b>Power Supply Cable Length:</b>	2.6m
<b>Mains Fuse:</b>	16A
<b>Power @ 50%:</b>	0.8kW
<b>Maximum Welding Power:</b>	6kW
<b>Maximum Short Circuit Current:</b>	2500A
<b>Weight:</b>	4.9kg



230V

16A



Supplied with accessories

B

### B SR2000P Stud Welding Puller

Stud Welding Puller for use with tabs and washers. Adjustable legs have four profiles on the base for different size and shapes of dents. Threaded centre can also be pulled through for use on larger dent removal.

<b>Size/Spread:</b>	190mm
<b>Reach:</b>	80mm



C

### C SR2000TS Tab Shooter for SR2000

Tab Shooter for use with Model No. SR2000. Holds multiple tabs (Model No. SR2000.T) and loads them semi-automatically for fast and efficient use. Guide on side provides quick and easy alignment for next tab.



### D-J NOT ILLUSTRATED Electrode Kit, Studs, Washers and Tabs for SR2000

Model No:	Description:	Pack Qty:
D SR2000.E	Electrode Kit	1
E SR2000.AM	Al-Mg Studs	10
F SR2000.AMS	Al-Mg-Si Studs	10
G SR2000.PW	Pull Washers	10
H SR2000.SW	Star Washers	10
I SR2000.T	Tabs	10
J SR2000.TW	Triangle Washers	10

L

NEW

Packs of 100/200  
2.5mm

M

NEW

Packs of 100/200  
2mm

N



Pack of 50

### L-N SEE BELOW Stud Welding Nails & Washers

Model No:	Description:	Pack Qty:
L PS/0002	Stud Welding Nail 2.5 x 50mm	100
L PS/000250/200	Stud Welding Nail 2.5 x 50mm	200
M PS/0003	Stud Welding Nail 2 x 50mm	100
M PS/000350/200	Stud Welding Nail 2 x 50mm	200
N PS/000450	Stud Welding Washer Ø8 x Ø16 x 1.5mm	50

O

### O RE100/WS Wavy-Wire Strip for Panel Pulling System

Pack of 50. Suitable for panel pulling systems.

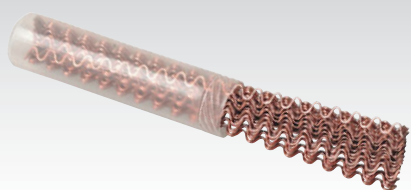

**A**

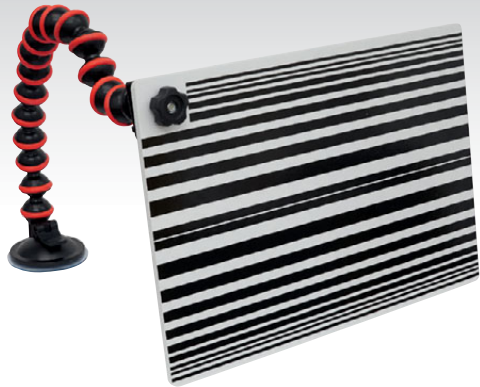

**A RE025  
PDR Line Board**

To be used alongside other dent repair tools for added accuracy. Suction cup and flexible neck provides precise positioning. Reflected lines distort when aligned over damaged area, providing visual aid when dressing the panel.

Board Size:	300 x 210mm
Stand Length:	410mm
Type:	Reflective

**B**



12V  
**LED**

**B RE025LED  
12V LED PDR Line Board**

To be used alongside other dent repair tools for additional accuracy. Suction cup and flexible neck provides precise positioning. Light box creates bold lines even in dark areas that distort when aligned over damaged area, providing visual aid when dressing the panel. Supplied with universal vehicle accessory socket plug.

Board Size:	270 x 155mm
Stand Length:	260mm
Type:	12V - LED

**C**



**C RT013  
PDR Knockdown Tool**

Features four interchangeable heads. The body has an optional extension to take length (including head) from 100mm to 130mm, allowing use in harder to reach areas. Ideal PDR tool for high spots and small dents. Heads include; parallel flat, tapered flat and two sized pointed. Knurled finish on tool for precision handling.

Minimum Length (inc. Head)	100mm
Maximum Length (inc. Head)	130mm

**D**

**NEW**



**D PST01  
2pc Panel Gap Setting Tool**

Panel gap setting tool with 10 plastic gauges and a suction cup for damage-free mounting and use. Each gauge is 1mm thick with alternating shades for easy selection. Ideal for use on panels gaps and windscreen mounting to ensure even gaps. Range of 1-10mm.

**E**

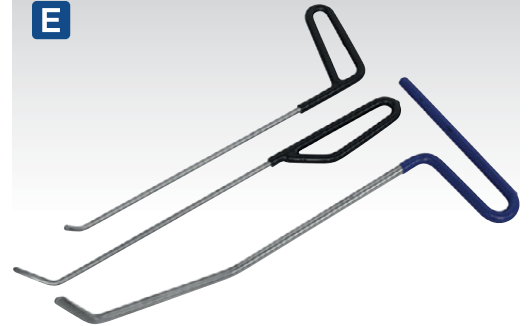

**E RE104  
3pc Paintless Dent Repair Kit**

Time-saving kit. Heavyweight, heat treated, high quality steel components are carefully shaped and finished to allow the technician (with practice) to coax out all manner of dents and creases from behind the body panel, without the need to respray/refinish the painted surface.

Contents:	8", 9", 12" Hooks
-----------	-------------------

**F**



**F RE102  
33pc Paintless Dent Repair Kit**

A comprehensive set of starter tools for the professional bodyshop technician. Heavyweight, heat treated, high quality steel components are carefully shaped and finished to allow the technician (with practice) to coax out all manner of dents and creases from behind the body panel, without the need to respray/refinish the painted surface. Time-saving kit of tools supplied in storage bag

Contents:	Lever Hooks, 45°-90° Flat Nose Bars, Flat Bar, 45° Flat Bar, Panel Bag, Window Wedge, Plastic Punch, Screw-on Plastic Rounded Tips, Door Jam, Curved Rounded Nose Hook Bar
-----------	--

**G**



**G RE103  
8pc Paintless Dent Repair Kit**

Heavyweight, heat treated, high quality steel components are carefully shaped and finished to allow the technician (with practice) to coax out all manner of dents and creases from behind the body panel, without the need to respray/refinish the painted surface. Time-saving kit supplied in storage bag.

Contents:	Flare Tip; 6", 7", 12", Serrated Flare Tip; 38", 90° Hook; 22", 45° Hook Tip Extension; 16", Angled Tip Extension; 20", 37"
-----------	---



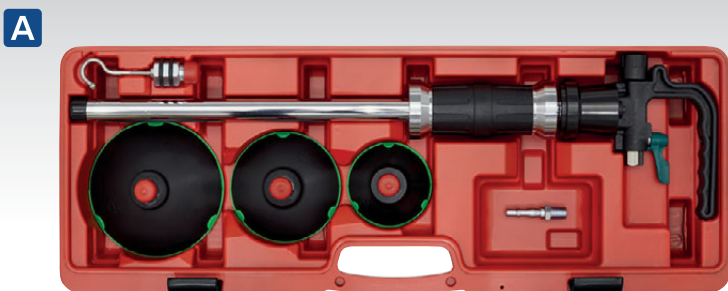

**AIR Operated**



**A RE101**  
**Air Suction Dent Puller**

Air activated suction pad keeps firm hold of panel while slide hammer is used to ease out dents and depressions without damage to the paint surface. Ideal for initial panel reshaping. Supplied with suction pads and hook.

Suction Pads:	Ø75, 100, 125mm
Hook Length:	90mm
Overall Length:	590mm



**AIR Operated**

**B RE012**  
**Plunger Type Air Suction Dent Puller**

Versatile suction dent puller fitted with integral vacuum generator/indicator. Retains a firm hold of the panel while the slide hammer is used to ease out dents and depressions - without damage to the painted finish. Ideal for initial panel reshaping. Supplied with suction pads and hook.

Suction Pads:	Ø75, 100, 125mm
Hook Length:	90mm
Overall Length:	730mm



**C-E SEE BELOW**  
**Professional Dent Pullers**

Specialist device for pulling dents from panels and bodywork. Contoured aluminium handle and suction release trigger give the technician close control.

	<b>C</b>	<b>D</b>	<b>E</b>
Model No:	AK100	AK101	AK102
Size:	Ø75mm	Ø100mm	Ø125mm
Maximum Pull Capacity:	10kg	15kg	20kg



**F AK98**  
**Ø150mm Suction Dent Puller**

Strong suction will pull-out panel dents, move glass panels and aid handling. Suction releases simply by lifting the edge.

Size:	Ø150mm
Maximum Pull Capacity:	20kg



**G RE006**  
**6pc Suction Clamp Set**

A great time-saving tool set. Secures panel trims, decals, badges, window trims, rain and light sensors to set. Non-marking, composite construction with adjustable reach and clamp.

Clamp Length:	180mm
---------------	-------

**H RE105**  
**Hot Glue Paintless Dent Repair Kit**

High quality kit for the removal of small dents without the need for respraying/refinishing the painted surface. Pulling tool for use on flat surface includes large rubber feet to avoid damage to the paintwork and rotates 360° to allow use in more restricted areas. Slide hammer is included for use on bigger dents and dents on corners or curves. 12 Plastic tabs of varying sizes and shapes are included to cover a wide range of dents. Kit includes plastic scraper and glue removal spray to avoid damage to surface.

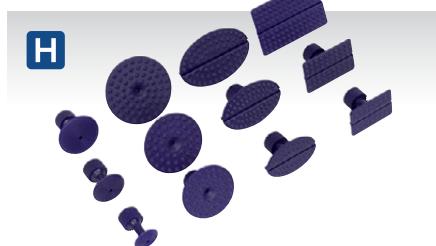

Contents:	360° Puller Tool, 60W/230V Glue Gun, Slide Hammer, Glue Removal Spray, Plastic Scraper, Dent Repair Glue Sticks (x8), Plastic Tabs (x12)
Model No:	RE105/1
Consumable Parts:	PDR Dent Repair Tabs - Pack of 12
	RE105/2
	PDR Glue Stick - Pack of 25





**A AK579**

**3pc Panel Seam Splitter Set**

Ideal for separating spot-welded panels during repairs. Chrome Molybdenum hammer-thru shafts. Soft grip handles for comfort and control. Includes straight, 30° offset and 90° angle splitters.

**Contents:** Straight, 30° Offset, 90° Angle



**B AK570**

**Flat Spot Weld Splitting Tool**

Chrome Vanadium steel flat splitting tool suitable for the manual cutting of spot welds.

**Length:** 240mm

**LIFETIME  
GUARANTEE\***



**C SA34**

**Reciprocating Air Saw**

For full details, see page 820.

**2 YEAR  
GUARANTEE\***

**Premier**



**D DP945**

**9pc 2.1kg Slide Hammer Kit**

Steel shaft hammer with comfortable plastic grip. 2.1kg Sliding weight. Supplied with various attachments.

**Sliding Weight:** 2.1kg(4.5lb)

**Attachments:** Small & Large Flat Hooks, Small & Large Round Hooks, Screw Holder, Adaptor, Self Tapping Screw, Taper Screw



**E DP935B**

**9pc 1.25kg Slide Hammer Kit**

Slide hammer kit with 1.25kg sliding weight. Comfortable rubber grip handle for added control. Supplied in storage case with attachments.

**Sliding Weight:** 1.25kg(2.75lb)

**Attachments:** Small & Large Flat Hooks, Small & Large Round Hooks, Screw Holder, Adaptor, Self Tapping Screw, Taper Screw

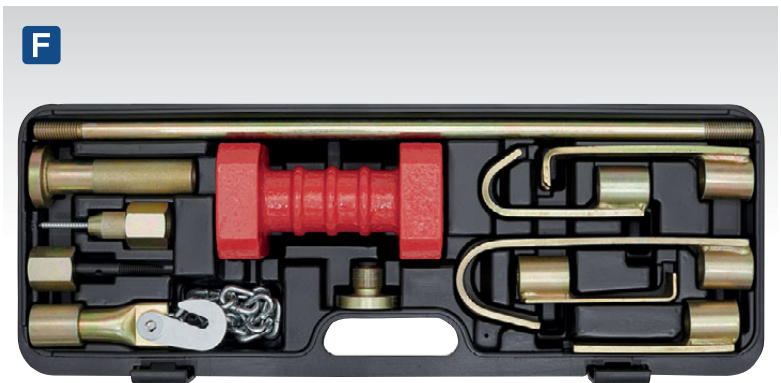

**F DP90**

**10pc 4.4kg Heavy-Duty Slide Hammer Set**

Heavy-duty slide hammer with 4.4kg sliding weight. For use on body panels and vehicle chassis. Supplied with various attachments in a tough storage case.

**Sliding Weight:** 4.4kg(10lb)

**Attachments:** Small & Large Flat Hooks, Small & Large Right Angle Hooks, Straight Bar, Hook with Chain, Self Tapping Screw, Taper Screw, Adaptor

**HEAVY  
DUTY**



**G DP9/5B**

**9pc 2kg Slide Hammer Kit**

Slide hammer kit with 2.04kg sliding weight. Comfortable rubber grip handle for added control. Supplied in storage case with attachments.

**Sliding Weight:** 2.04kg(4.5lb)

**Attachments:** Small & Large Flat Hooks, Small & Large Round Hooks, Screw Holder, Adaptor, Self Tapping Screw, Taper Screw

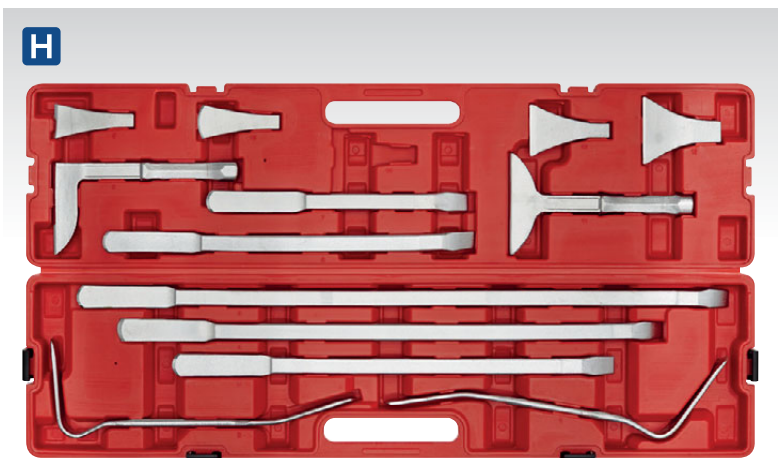

**H CB50**

**13pc Body Panel Levering/Separating Tool Set**

Assortment of body repair tools, designed for levering, separating and reforming of panels. Supplied in storage case.

**Maximum Bar Length:** 900mm





A



B

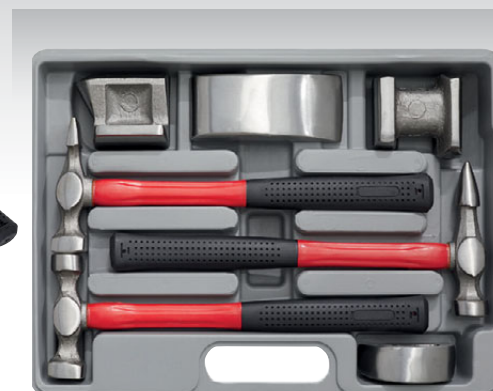

A

### B CB707 7pc Drop-Forged Panel Beating Set with Fibreglass Shafts

Polished, drop-forged steel dollies. Hammers with fibreglass handle and rubber grips. Supplied in storage case.

**Contents:** Hammers; Bumping, Pick, Straight, Dollies; Universal, Heel, Curved, Mushroom

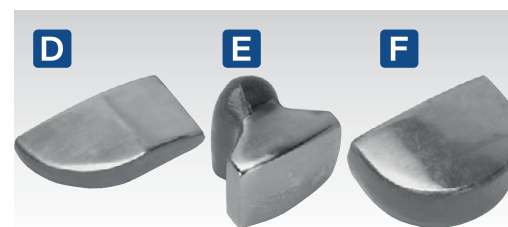

D

E

F

### A CB507 7pc Drop-Forged Panel Beating Set with Hickory Shafts

Polished, drop-forged steel dollies. Professional hickory handled hammers. Supplied in storage case.

**Contents:** Hammers; Bumping, Pick, Straight, Dollies; Universal, Heel, Curved, Mushroom



C



G

H



I

J



K

L



M NEW



### M SPG01 Contour Gauge with Lock

For full details, see page 721.

### C D-L SEE BELOW Panel Beating Tools



C

### C CB58 9pc Panel Beating Set

Drop-forged steel dollies and spoons. Professional hickory handled hammers. Supplied in storage case.

**Contents:** Hammers; Bumping, Skinning, Pein/Finish, Pick/Finish, Dollies; Toe, Universal, Heel, Spoons; Dinging, Surfacing

<b>D</b> Model No:	CB58.01
Description:	Toe Dolly
<b>E</b> Model No:	CB58.02
Description:	Universal Dolly
<b>F</b> Model No:	CB58.03
Description:	Heel Dolly
<b>G</b> Model No:	CB58.04
Description:	Dinging Spoon
<b>H</b> Model No:	CB58.05
Description:	Surfacing Spoon
<b>I</b> Model No:	CB58.06
Description:	Standard Bumping Hammer
<b>J</b> Model No:	CB58.07
Description:	Door Skinning Hammer
<b>K</b> Model No:	CB58.08
Description:	Pein & Finish Hammer
<b>L</b> Model No:	CB58.09
Description:	Pick & Finish Hammer



**A AK327**  
**Hand Nibbler Shears**

Suitable for cutting metal and plastics without panel distortion. Interchangeable Chrome Molybdenum steel cutting jaws with safety lock. Contour grip, non-slip handles for extra comfort and safety. Blades are consumable items and are not covered by the lifetime guarantee.

Maximum Thickness:	1.2mm Steel
Maximum Hardness:	85 HRC
Centre Blade Replacement:	AK327/B



**D AK6915**  
**280mm Offset Tin Snips**

Offset head for easier cutting. Drop-forged Chrome Molybdenum steel blades for greater strength and durability. Electrodeposition finish to prevent the onset of rust and composite handles for added comfort. Cuts up to 1mm cold rolled steel or 0.6mm stainless steel.

Cutting Capacity:	1mm
Length:	280mm

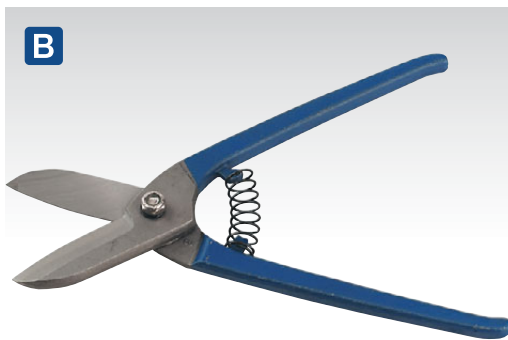

**B AK6910**  
**250mm Spring Loaded Tin Snips/Shears**

One-piece, drop-forged blades with spring loaded handles. Suitable for cutting thin gauge ferrous and non-ferrous metal sheet.

Cutting Capacity:	0.8mm
Length:	250mm



**E AK6907**  
**3pc Aviation Tin Snip Set**

Drop-forged, Chrome Vanadium, tempered steel blades with serrated jaws. Self-opening, spring action handles with composite, contoured, colour-coded grips with safety catch.

Contents:	Left, Right, Straight Cut
Cutting Capacity:	1mm
Length:	250mm



**C AK6829**  
**200mm Sheet Metal Clamp**

Heat treated Chrome Molybdenum and Chrome Vanadium steel construction with a nickel-plated smooth satin finish. Spring loaded locking mechanism prevents nipping fingertips when releasing. Heavily knurled adjustment screw for extra grip with greasy fingers.

Jaw Capacity:	30mm
Length:	200mm



**F-H SEE BELOW**  
**Aviation Tin Snips**

Drop-forged, Chrome Vanadium, tempered steel blades with serrated jaws. Self-opening, spring action handles with composite, contoured, colour-coded grips with safety catch.

Model No:	AK6904	AK6905	AK6906
Type:	Straight Cut	Left Cut	Right Cut
Cutting Capacity:	1mm	1mm	1mm
Length:	250mm	250mm	250mm



**I AK69073**  
**3pc High Leverage Aviation Tin Snip Set**

Drop-forged, Chrome Molybdenum, tempered steel blades with serrated jaws. Self-opening, spring action handles with composite, contoured, colour-coded grips with safety catch.

Contents:	Left, Right, Straight Cut
Cutting Capacity:	1mm
Length:	275mm



**J AK69072**  
**2pc High Leverage Offset Aviation Tin Snip Set**

Drop-forged, Chrome Molybdenum, tempered steel blades with serrated jaws and offset head for easier cutting. Self-opening, spring action handles with composite, contoured, colour-coded grips with safety catch.

Contents:	Left, Right Cut
Cutting Capacity:	1mm
Length:	265mm





Premier

LIFETIME GUARANTEE\*

**A AK68403**  
6pc Axial Locking Grip Set  
For full details, see page 225.

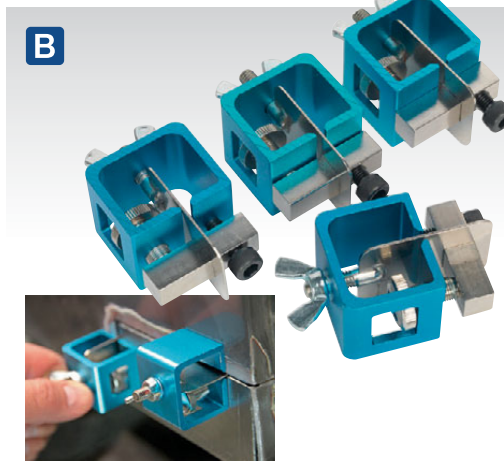

**B AK6805**  
4pc Butt Welding Clamp Set  
An effective method for creating an evenly spaced butt weld joint. Built-in level adjustment of 0-3mm either side allows different thickness materials to be accurately aligned.



**C AK6804**  
4pc Micro Welding Clamp Set  
Small and compact with exceptional clamping force. Ideal for automotive applications when positioning body panels prior to welding. Micro clamp enables areas to be secured where other tools struggle to fit, such as door columns and window edges.

Jaw Capacity: 7mm



**D RE92/30**  
Jogger/Flanging Tool  
All steel construction with spring loaded handles. Precision jaws make 10mm flange on 18-20 gauge mild steel or aluminium sheet and provide smooth, flush joint between panels. Fitted with non-slip PVC grips.

Length: 280mm

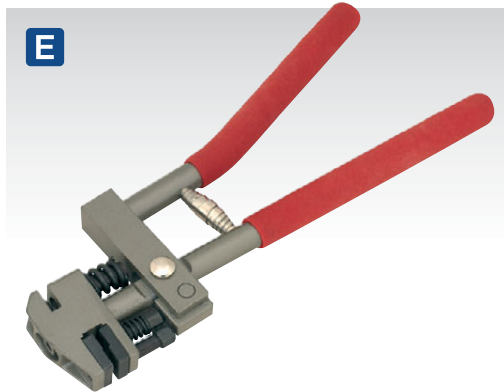

**E RE92/31**  
Jogger/Flanging & Punch Tool  
All steel construction with swivel head. Jogger tool produces a 10mm flange on 18-20 gauge mild steel or aluminium sheet. Push and turn head to produce Ø6mm holes. Ideal for spot/MIG welding car panels. Fitted with non-slip PVC grips.

Length: 290mm

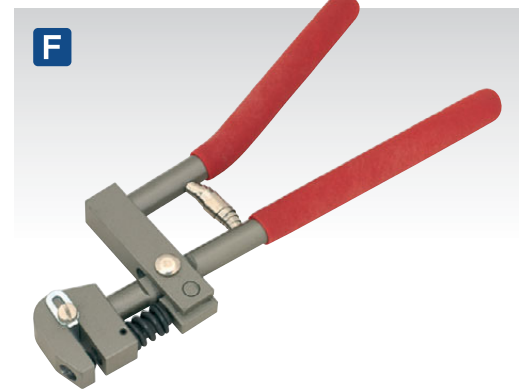

**F RE92/35**  
Ø5mm Punch Tool  
All steel construction with spring loaded handles. Ø5mm Holes are suitable for preparing panels for MIG/spot welding. Fitted with non-slip PVC grips.

Throat Depth: 15mm  
Maximum Material Thickness: 1mm  
Length: 290mm



**G RE92/33**  
Door Skin Folding Tool  
Suitable for preforming and finishing door skins onto door frames. Also suitable for joining sheet material. Fitted with nylon pad to prevent panel deformation.

Length: 320mm



**H AK9821**  
14pc Metal Punch Set  
Heavy-duty drop-forged and heat treated steel punch body with compound lever action. Suitable for precision punching of holes in steel, aluminium, brass, copper and plastic. Fitted with gauge for depth adjustment up to 50mm. Suitable for materials up to 14 gauge. Punches and dies hardened to 55-60 HRC. Supplied in storage case.

Contents: Punch & Die Sizes; 3/32", 1/8", 5/32", 3/16", 7/32", 1/4", 9/32"

HEAVY DUTY



**A AK9752**  
**154mm Carbide Tipped Scriber**  
 Fitted with pocket-clip. Suitable for use on glass, metals and ceramics. Ideal for machinists, welders, tinsmiths and hobbyists.

**Length:** 154mm

**B AK9751**  
**190mm Double End Engineer's Scriber**  
 Precision manufactured tool with hardened steel tips. Features straight and 90° tips with knurled body.

**Length:** 190mm

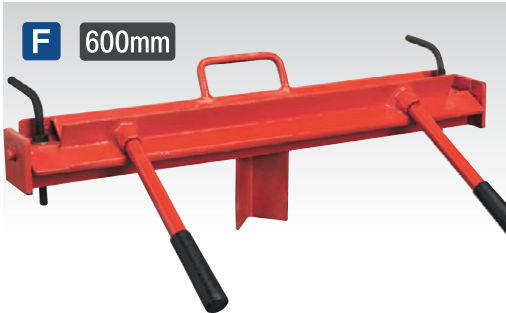

**F DF600**  
**600mm Vice Mounting Metal Folder**  
 Suitable for use in a sturdy bench mounted vice and capable of bending up to 22 gauge steel sheet. Ideal for small garage or restoration operation.

**Capacity:** 600mm x 22 Gauge Sheet, Ø2mm Rod

**G TS01**  
**700mm Vice/Bench Mounting Sheet Metal Folder**  
 Bench and vice mounting sheet metal folder, fitted with mounting plates. Capable of bending up to and beyond a 90° angle. The unique patented endless design and removable folding plate allows the user to fold, channel and offset any length of sheet metal up to 20 gauge thick, by simply moving the sheet as required after each fold. With adjustable fold plate to help achieve the cleanest fold possible. Ideal for the small garage or restoration operation.

**Capacity:** 700mm x 20 Gauge Sheet, Ø1mm Rod

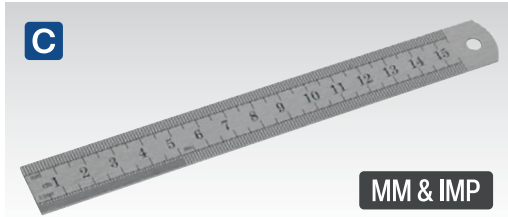

**C SEE BELOW**  
**Steel Rules**  
 High quality steel rules permanently marked in Metric and Imperial graduations. All rules include hanging hole.

Model No:	Length:
AK9640	150mm/6"
AK9641	300mm/12"
AK9642	600mm/24"
AK9643	1000mm/40"



**E DF760**  
**760mm Bench Mounting Metal Folder**  
 Bench mounting sheet metal folder, fitted with mounting plates. Capable of bending up to 17 gauge steel sheet. Ideal for the small garage or restoration operation. Suitable clamps (not included) are required to secure the pressing plate for operation.

**Capacity:** 760mm x 17 Gauge Sheet, Ø2mm Rod

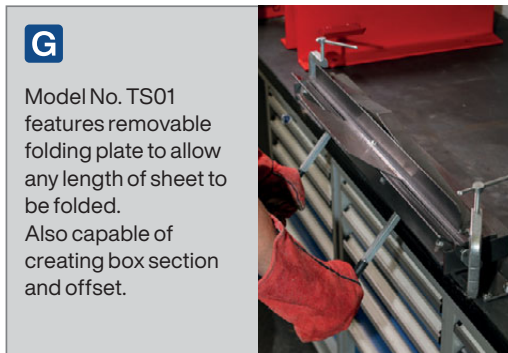

**700mm**  
**Removable Folding Plate**

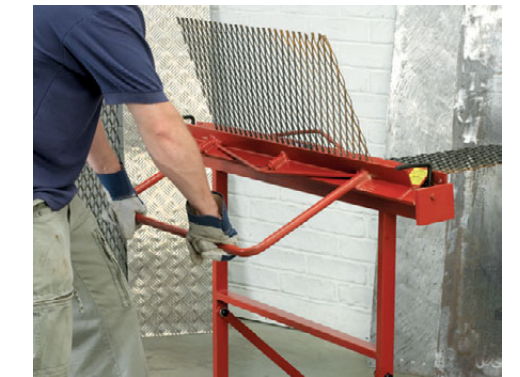

**D DF910**  
**910mm Floor Standing Metal Folder**  
 Floor standing metal folder with 910mm capacity. Manually operated and suitable for folding up to 22 gauge sheet.

**Capacity:** 910mm x 22 Gauge Sheet, Ø2mm Rod







**A S0469**  
**Hand Riveter**

Drop-forged aluminium body with heavy-duty SCM4 grade jaws, carbon steel jaw case and pin. PVC Handle grips. Four nozzles to accept 2.4mm(3/32"), 3.2mm(1/8"), 4mm(5/32") and 4.8mm(3/16") rivets. Supplied with nozzle spanner.

Length:	255mm
Rivet Types:	
Aluminium:	✓
Steel:	✗
Stainless Steel:	✗
Structural:	✗



**D AK3991**  
**Swivel Head Riveting Kit**

Pressed steel body with cast swivel head and Chrome Molybdenum steel jaws. Curve design provides integral strength and rubber grip handle for added comfort. Supplied with four rivet nozzles to accept 2.4mm(3/32"), 3.2mm(1/8"), 4mm(5/32") and 4.8mm(3/16") rivets. Suitable for aluminium (2.4mm, 3.2mm, 4.0mm, 4.8mm) steel and stainless steel rivets (2.4mm, 3.2mm, 4.0mm). Includes a selection of approximately 80 rivets.

Length:	275mm
Rivet Types:	
Aluminium:	✓
Steel:	✓
Stainless Steel:	✓
Structural:	✗



**F AK393**  
**Threaded Nut Riveting Kit**

Strong body design and rubber handle grips provide effortless functionality suitable for aluminium nut rivets. Includes 40 assorted nut rivets.

Length:	255mm
Includes:	M3 x 0.5, M4 x 0.7, M5 x 0.8, M6 x 1mm
Rivet Types:	
Aluminium:	✓
Steel:	✗
Stainless Steel:	✗
Structural:	✗



**B AK99**  
**Riveting Kit**

High grade aluminium die-cast body with composite covered handles for added grip. Heat treated chrome steel jaws and jaw case. Four nozzles to accept 2.4mm(3/32"), 3.2mm(1/8"), 4mm(5/32") and 4.8mm(3/16") rivets. Supplied with nozzle spanner. Includes a selection of aluminium rivets.

Length:	250mm
Rivet Types:	
Aluminium:	✓
Steel:	✗
Stainless Steel:	✗
Structural:	✗



**E AK397**  
**2-Way Riveting Kit**

2-Position head allows jaws to work either at 90° or 180° to the workpiece. Chrome Molybdenum jaws in steel jaw case. Supplied with four nozzles to accept 2.4mm(3/32"), 3.2mm(1/8"), 4mm(5/32") and 4.8mm(3/16") rivets. Suitable for aluminium and steel rivets. Supplied in storage case with nozzle spanner and a selection of approximately 60 assorted rivets.

Length:	280mm
Rivet Types:	
Aluminium:	✓
Steel:	✓
Stainless Steel:	✗
Structural:	✗



**G RT001**  
**Plastic Riveting Kit**

Suitable for applying plastic rivets found mainly in automotive applications. Designed for one-handed operation and one-stroke setting. Allows access in hard-to-reach areas not accessible by conventional lever type tools. Universal nose piece suitable for all sizes of plastic rivets. Supplied with four packs of plastic rivets.

Rivets:	Ø5 x 15.8, Ø5 x 17.2, Ø6.3 x 25.2, Ø6.6 x 17.2mm (10 of each)
---------	---



**C AK992**  
**Heavy-Duty Riveter**

High grade aluminium die-cast body with heat treated carbon steel handle. Heat treated chrome steel 3-piece jaws and jaw case. Composite handgrips with spanner storage. Four nozzles to accept 2.4mm(3/32"), 3.2mm(1/8"), 4mm(5/32") and 4.8mm(3/16") rivets. Supplied with nozzle spanner.

Length:	250mm
Rivet Types:	
Aluminium:	✓
Steel:	✓
Stainless Steel:	✓
Structural:	✗

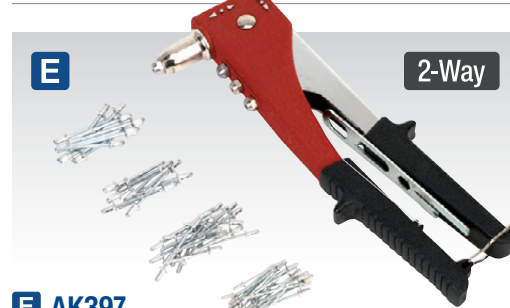

**H AK499**  
**Plastic Riveting Kit**

Designed for the installation of plastic rivets where accessibility is restricted due to angle or reach. Universal nose piece suitable for all sizes of plastic rivets. Supplied with four packs of plastic rivets.

Length:	220mm
Rivets:	Ø5 x 15.8, Ø5 x 17.2, Ø6.3 x 25.2, Ø6.6 x 17.2mm (10 of each)

**A**

**HEAVY DUTY**



**A AK3982**  
**Heavy-Duty Compact Riveter with Collection Bowl**

Industrial grade tool for use in garages, agriculture and general workshops. Short-arm design providing effortless functionality and access to restricted space to set rivets up to 6.4mm. Supplied with five interchangeable colour-coded nozzles for all popular rivet sizes. Accepts aluminium, steel and stainless steel rivets in the following sizes: Metric; 2.4, 3.2, 4, 4.8, 6.4mm, Imperial; 3/32", 1/8", 5/32", 3/16", 1/4". Features special profile nozzle for structural rivets and a built-in mandrel collector.

<b>Length:</b>	325mm
<b>Includes:</b>	Nozzles; 2.4(3/32"), 3.2(1/8"), 4(5/32"), 4.8(3/16"), 6.4mm(1/4")
<b>Rivet Types:</b>	
<b>Aluminium:</b>	✓
<b>Steel:</b>	✓
<b>Stainless Steel:</b>	✓
<b>Structural:</b>	✓

**B**



**B AK3983**  
**Medium-Arm Riveter with Collection Bowl**

Chrome Molybdenum jaws and steel handles for extra leverage, provide effortless functionality. Suitable for aluminium, steel, stainless steel and structural rivets up to 6.4mm(1/4").

<b>Length:</b>	390mm
<b>Includes:</b>	Nozzles; 2.4(3/32"), 3.2(1/8"), 4(5/32"), 4.8(3/16"), 6.4mm(1/4")
<b>Rivet Types:</b>	
<b>Aluminium:</b>	✓
<b>Steel:</b>	✓
<b>Stainless Steel:</b>	✓
<b>Structural:</b>	✓



**C**

**C AK3987**  
**Riveter**

Curved design provides integral strength and rubber grip handle gives added comfort. Suitable for aluminium, steel and stainless steel rivets.

<b>Length:</b>	210mm
<b>Includes:</b>	2.4(3/32"), 3.2(1/8"), 4(5/32"), 4.8mm(3/16")
<b>Rivet Types:</b>	
<b>Aluminium:</b>	✓
<b>Steel:</b>	✓
<b>Stainless Steel:</b>	✓
<b>Structural:</b>	✗



**D**

**D AK3986**  
**Threaded Nut Riveter**

Curve design provides integral strength. Rubber grip handle for added comfort. Suitable for aluminium, steel and stainless steel nuts.

<b>Length:</b>	210mm
<b>Includes:</b>	M3 x 0.5, M4 x 0.7, M5 x 0.8, M6 x 1mm
<b>Rivet Types:</b>	
<b>Aluminium:</b>	✓
<b>Steel:</b>	✓
<b>Stainless Steel:</b>	✓
<b>Structural:</b>	✗



**E**

**HEAVY DUTY**



**E AK3981**  
**Heavy-Duty Long-Arm Riveter with Collection Bowl**

Precision made, high grade alloy steel jaws with strong aluminium body. Forged alloy steel pins and bolts with double handle bearings for long-life and durability. Suitable for blind rivets. Includes Chrome Molybdenum special profile nozzles for structural rivets up to 6.4mm(1/4").

<b>Length:</b>	540mm
<b>Includes:</b>	Nozzles; 4.8mm(3/16"), 6.4mm(1/4"), Structural Steel Nozzles; 4.8mm(3/16"), 6mm, 6.4mm(1/4"), Spanner
<b>Rivet Types:</b>	
<b>Aluminium:</b>	✓
<b>Steel:</b>	✓
<b>Stainless Steel:</b>	✓
<b>Structural:</b>	✓

**F**



**F AK3984**  
**Short-Arm Threaded Nut Riveter**

Suitable for rivet nuts in aluminium, steel and stainless steel. Short-arms provide effortless functionality and access to restricted spaces.

<b>Length:</b>	285mm
<b>Includes:</b>	M3 x 0.5, M4 x 0.7, M5 x 0.8, M6 x 1, M8 x 1.25mm
<b>Rivet Types:</b>	
<b>Aluminium:</b>	✓
<b>Steel:</b>	✓
<b>Stainless Steel:</b>	✓
<b>Structural:</b>	✗

**G**



**G AK3985**  
**Long-Arm Threaded Nut Riveter**

Suitable for rivet nuts in aluminium, steel and stainless steel. Long-arms provide effortless functionality with adjustable stroke scale for improved accuracy.

<b>Length:</b>	410mm
<b>Includes:</b>	M3 x 0.5, M4 x 0.7, M5 x 0.8, M6 x 1, M8 x 1.25, M10 x 1.5, M12 x 1.75mm
<b>Rivet Types:</b>	
<b>Aluminium:</b>	✓
<b>Steel:</b>	✓
<b>Stainless Steel:</b>	✓
<b>Structural:</b>	✗

**H**



**H AK3988**  
**Medium-Arm Quick Release Threaded Nut Riveter**

Suitable for rivet nuts in aluminium, steel and stainless steel. Medium arms provide effortless functionality and pull through quick release mechanism.

<b>Length:</b>	345mm
<b>Includes:</b>	M3 x 0.5, M4 x 0.7, M5 x 0.8, M6 x 1, M8 x 1.25, M10 x 1.5, M12 x 1.75mm
<b>Rivet Types:</b>	
<b>Aluminium:</b>	✓
<b>Steel:</b>	✓
<b>Stainless Steel:</b>	✓
<b>Structural:</b>	✗



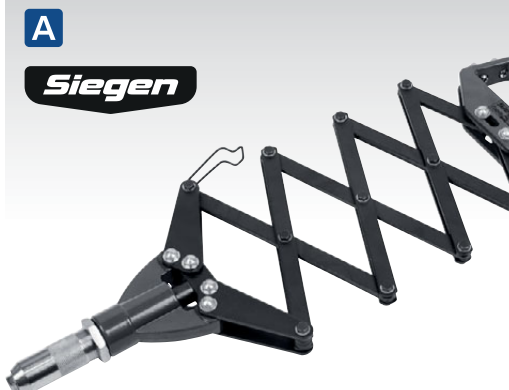

**A S0492**  
**Lazy Tongs Riveter**

Die-cast head with steel jaw case and Chrome Molybdenum jaws for aluminium, steel and stainless steel rivets. Suitable for repetitive riveting tasks. Supplied with five nozzles.

<b>Length:</b>	820mm
<b>Includes:</b>	Nozzles; 3.2mm(1/8"), 4mm(5/32"), 4.8mm(3/16"), 6mm, 6.4mm(1/4")
<b>Rivet Types:</b>	
<b>Aluminium:</b>	✓
<b>Steel:</b>	✓
<b>Stainless Steel:</b>	✓
<b>Structural:</b>	✗

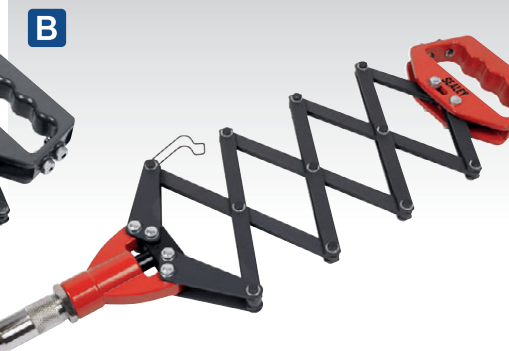

**B AK39902**  
**Lazy Tongs Riveter**

Aluminium head with steel jaw case and Chrome Molybdenum jaws for aluminium, steel and stainless steel rivets. Suitable for repetitive riveting tasks. Supplied with five nozzles.

<b>Length:</b>	880mm
<b>Nozzles:</b>	3.2mm(1/8"), 4mm(5/32"), 4.8mm(3/16"), 6mm, 6.4mm(1/4")
<b>Rivet Types:</b>	
<b>Aluminium:</b>	✓
<b>Steel:</b>	✓
<b>Stainless Steel:</b>	✓
<b>Structural:</b>	✗



**C AK399**  
**Lazy Tongs Riveter**

Aluminium head with steel jaw case and 3-piece jaws for blind aluminium, steel and stainless steel rivets. Suitable for repetitive riveting tasks. Knurled nozzles for quick changing. Supplied with five nozzles.

<b>Length:</b>	790mm
<b>Includes:</b>	Nozzles; 2.4mm(3/32"), 3.2mm(1/8"), 4mm(5/32"), 4.8mm(3/16"), 6.4mm(1/4")
<b>Rivet Types:</b>	
<b>Aluminium:</b>	✓
<b>Steel:</b>	✓
<b>Stainless Steel:</b>	✓
<b>Structural:</b>	✗



**D AK3990**  
**Quick Action Riveter**

Aluminium head with steel 3-piece jaws for aluminium, steel and stainless steel rivets. Patented design allows one-handed fast operation. Suitable for repetitive riveting tasks. Supplied with four nozzles.

<b>Length:</b>	270mm
<b>Includes:</b>	Nozzles; 2.4mm(3/32"), 3.2mm(1/8"), 4mm(5/32"), 4.8mm(3/16")
<b>Rivet Types:</b>	
<b>Aluminium:</b>	✓
<b>Steel:</b>	✓
<b>Stainless Steel:</b>	✓
<b>Structural:</b>	✗



**E AB074BR**  
**200pc Black Anodised Rivet Assortment**

<b>Contents (Approximate Quantity):</b>	Standard Flange; 3.2 x 8 (x25), 4.0 x 10 (x25), 4.8 x 14mm (x25); Large Flange; 3.2 x 10 (x25), 4 x 10 (x25), 4 x 14 (x25), 4.8 x 14 (x25), 4.8 x 18mm (x25)
---	--



**G DRA01**  
**Drill Powered Riveter Adaptor**

Suitable for use with electric drills with torque in excess of 11Nm. Fitted with 1/4" shank for easy fitting in to the drill chuck. Supplied with 2.4, 3.2, 4 and 4.8mm rivet nozzles. Suitable for use with aluminium, steel and stainless steel pop rivets.

<b>Rivet Type:</b>	Aluminium, Steel, Stainless Steel
<b>Maximum RPM:</b>	1000rpm
<b>Minimum Torque Required:</b>	11Nm
<b>Nozzle Sizes:</b>	2.4, 3.2, 4, 4.8mm



**F CP314**  
**20V 2Ah Cordless Riveter**

Suitable for aluminium, steel and stainless steel rivets from 2.4 to 4.8mm. Powered by a 20V 2Ah Li-ion battery with a pulling force of up to 9000N. Four selectable power settings help preserve battery by only supplying the force required. LED battery level indicator. Four riveting nozzles, 2.4mm, 3.2mm, 4mm and 4.8mm. Supplied in durable plastic storage case with mains charger and 2Ah battery.

<b>Nozzle Sizes:</b>	2.4, 3.2, 4, 4.8mm
<b>Maximum Pulling Force:</b>	9000N
<b>Battery:</b>	20V 2Ah Lithium-ion
<b>Weight:</b>	1.4kg
<b>Rivet Types:</b>	
<b>Aluminium:</b>	✓
<b>Steel:</b>	✓
<b>Stainless Steel:</b>	✓

**A NEW**



Swivel Head



**A AK3992**

**Swivel Head 2-in-1 Riveter**

360° Swivel head gives greatly improved accessibility. Four nozzles for standard rivets and four mandrels for rivet nuts. Pressed steel body with cast swivel head and Chrome Molybdenum steel jaws. Rubber grip handle for added comfort. Supplied with nozzle spanner.

<b>Length:</b>	275mm
<b>Blind Rivet Nozzle Sizes:</b>	2.4(3/32"), 3.2(1/8"), 4(5/32"), 4.8mm(3/16")
<b>Rivet Nut Sizes:</b>	M3 x 0.5, M4 x 0.7, M5 x 0.8, M6 x 1mm
<b>Rivet Materials:</b>	Aluminium, Steel, Stainless Steel

**B Swivel Head**



**B AK396**

**Swivel Head 3-in-1 Riveter**

Suitable for blind rivets, rivet nuts and rivet studs in aluminium, steel and stainless steel. 360° Swivel head gives greatly improved accessibility. Four nozzles for standard rivets, four mandrels for rivet nuts and three mandrels for rivet studs. Supplied with spanners and a selection of steel rivet nuts.

<b>Blind Rivet Nozzle Sizes:</b>	2.4(3/32"), 3.2(1/8"), 4(5/32"), 4.8mm(3/16")
<b>Rivet Nut Sizes:</b>	M3 x 0.5, M4 x 0.7, M5 x 0.8, M6 x 1mm
<b>Rivet Stud Sizes:</b>	M4 x 0.7, M5 x 0.8, M6 x 1mm
<b>Rivet Materials:</b>	Aluminium, Steel, Stainless Steel
<b>Rivets Nuts Supplied:</b>	M3 x 0.5, M4 x 0.7, M5 x 0.8, M6 x 1mm (10pc each)

**C NEW**

**HEAVY DUTY**



**C AK3989**

**Heavy-Duty 2-in-1 Compact Riveter**

Comfortable ergonomic grips. Heavy-duty head suitable for fixing blind rivets and threaded nut rivets to thin sheet aluminium, steel and stainless steel. Short arms provide effortless functionality and access to restricted spaces. Supplied with nozzle spanner.

<b>Length:</b>	255mm
<b>Blind Rivet Sizes:</b>	2.4mm(3/32"), 3.2mm(1/8"), 4mm(5/32"), 4.8mm(3/16"), 6.4mm(1/4")
<b>Rivet Nut Sizes:</b>	M3 x 0.5, M4 x 0.7, M5 x 0.8, M6 x 1, M8 x 1.25, M10 x 1.5mm
<b>Rivet Materials:</b>	
<b>Aluminium:</b>	✓
<b>Steel:</b>	✓
<b>Stainless Steel:</b>	✓
<b>Structural:</b>	✓

**D**



**D AK39602**

**Rivet & Threaded Nut Rivet Kit**

Drop-forged frame with patented folding mechanism for compact storage. Comfortable cushion grips. Heavy-duty head suitable for fixing blind rivets and threaded nut rivets to thin sheet material.

<b>Blind Rivet Sizes:</b>	3.2mm(1/8"), 4mm(5/32"), 4.8mm(3/16"), 6mm(1/4"), 6.4mm(1/4")
<b>Rivet Nut Sizes:</b>	M4 x 0.7, M5 x 0.8, M6 x 1, M8 x 1.25, M10 x 1.5mm
<b>Folded Length:</b>	300mm
<b>Unfolded length:</b>	520mm
<b>Rivet Materials:</b>	Aluminium, Steel, Stainless Steel





**A SA31**  
**Air/Hydraulic Riveter**  
Powerful tool suitable for both aluminium and blind steel rivets up to 3/16". Supplied with four riveting nozzles and two spanners. Trigger operated riveter with hardened steel jaw assembly and rivet shaft safety cap.

**B SA312**  
**Air/Hydraulic Riveter**  
Suitable for aluminium, steel and stainless steel rivets up to 3/16". Supplied with four riveting nozzles and two spanners. Trigger operated riveter with hardened steel jaw assembly and rivet shaft safety cap. Will handle heavy assembly work.

**C GSA312**  
**Air/Hydraulic Riveter**  
Suitable for aluminium, steel and stainless steel rivets up to 3/16". Supplied with four riveting nozzles and two spanners. Trigger operated riveter with hardened steel jaw assembly and rivet shaft safety cap. Will handle heavy assembly work. Composite handle insulates user from chill and vibration.

**D SA314**  
**Heavy-Duty Air/Hydraulic Riveter**  
Heavy-duty model suitable for aluminium, steel and stainless steel rivets up to 1/4". Supplied with five riveting nozzles and two spanners. Trigger operated riveter with hardened steel jaw assembly and rivet shaft safety cap. Ideal for heavy assembly work.



**E GSA314**  
**Heavy-Duty Air/Hydraulic Riveter**  
Heavy-duty model suitable for aluminium, steel and stainless steel rivets up to 1/4". Supplied with five riveting nozzles and two spanners. Trigger operated riveter with hardened steel jaw assembly and rivet shaft safety cap. Ideal for heavy assembly work. Composite handle insulates user from chill and vibration.

**F SA316**  
**Air/Hydraulic Riveter Vacuum System**  
Powerful tool suitable for aluminium, steel, stainless steel and structural blind rivets up to 1/4". Trigger operated riveter with hardened steel jaw assembly and air-actuated vacuum rivet shaft collector. Grip for added comfort and hanging loop for use with balancer. Supplied with three riveting nozzles, two spanners and oil can.



	A	B	C	D	E	F
<b>Model No:</b>	SA31	SA312	GSA312	SA314	GSA314	SA316
<b>Nozzle Sizes:</b>	3/32"(2.4mm) 1/8"(3.2mm) 5/32"(4mm) 3/16"(4.8mm)	3/32"(2.4mm) 1/8"(3.2mm) 5/32"(4mm) 3/16"(4.8mm)	3/32"(2.4mm) 1/8"(3.2mm) 5/32"(4mm) 3/16"(4.8mm)	3/32"(2.4mm) 1/8"(3.2mm) 5/32"(4mm) 3/16"(4.8mm) 1/4"(6.4mm)	3/32"(2.4mm) 1/8"(3.2mm) 5/32"(4mm) 3/16"(4.8mm) 1/4"(6.4mm)	3/16"(4.8mm) 7/32"(5.6mm) 1/4"(6.4mm)
<b>Air Consumption:</b>	4cfm	4cfm	4cfm	4cfm	4cfm	4cfm
<b>Operating Pressure:</b>	90psi	90psi	90psi	90psi	90psi	90psi
<b>Inlet Size:</b>	1/4"BSP	1/4"BSP	1/4"BSP	1/4"BSP	1/4"BSP	1/4"BSP
<b>Blind Rivet Type:</b>						
<b>Aluminium:</b>	✓	✓	✓	✓	✓	✓
<b>Steel:</b>	✓	✓	✓	✓	✓	✓
<b>Stainless Steel:</b>	✗	✓	✓	✓	✓	✓
<b>Structural:</b>	✗	✗	✗	✗	✗	✓
<b>Noise Power/Pressure:</b>	80/72dB(A)	80/72dB(A)	80/73dB(A)	80/72dB(A)	80/73dB(A)	82/71dB(A)
<b>Weight:</b>	1.3kg	1.3kg	1.3kg	1.6kg	1.6kg	1.9kg

**G SA317**  
**Air/Hydraulic Nut Riveter Vacuum System**  
Heavy-duty, suitable for all types of nut rivets. Supplied with seven mandrels, two spanners and oil syringe. Trigger operated with automatic wind release for fast application. Will handle heavy assembly work.

**Mandrel Sizes:** M3, M4, M5, M6, M8, M10, M12  
**Air Consumption:** 4.5cfm  
**Operating Pressure:** 100psi  
**Inlet Size:** 1/4"BSP  
**Stroke Range:** 1-8mm  
**Noise Power/Pressure:** 89/78dB(A)  
**Weight:** 2.6kg

**A**

**Recirculating**

Supplied with 700g bottle of shot blasting grit.



**A SG10E**

**Air Recirculating Sandblasting Kit**

Suitable for use in the bodyshop. The feathering action makes this blaster ideal for treating stone chips. Supplied with a set of four rubber nozzles for sealing the gun head to the panel and a 700g bottle of blasting grit. Replacement nozzles are available.

<b>Operating Pressure:</b>	60-120psi
<b>Air Consumption:</b>	5-10cfm
<b>Replacement Nozzles:</b>	SG10/ACC

**D**



**D SSG8**

**Sandblasting Gun with 6mm Nozzle**

Suitable for cleaning small areas such as wheels or chassis members. This gun will accept a variety of abrasives including sand, chilled iron grit and other proprietary types of beading.

<b>Nozzle Diameter:</b>	Ø6mm
<b>Operating Pressure:</b>	90-120psi
<b>Air Consumption:</b>	14-18cfm

**B**

**25kg**



**B SEE BELOW**

**25kg Shot Blasting Grit**

Suitable for both hand held and recirculating shot blasters. Complies with COSHH SI-1657-1988. Not suitable for use in shot blasting cabinets.

Model No:	Size:	Container:
B/25KG	200-700microns	Bag
BGT25KG	200-700microns	Tub

**E**



**E SSG9**

**Bulk Feed Sandblasting Gun with Ø6mm Nozzle**

Suitable for cleaning large areas, this gun will accept a variety of abrasives including sand, chilled iron grit and other proprietary types of beading.

<b>Nozzle Diameter:</b>	Ø6mm
<b>Operating Pressure:</b>	30-70psi
<b>Air Consumption:</b>	6cfm
<b>Hose Length:</b>	1m

**G SG10/SAND6**

**Shot Blasting Sand - Pack of 6**

Suitable for Sealey and other recirculating shot blasters. Complies with COSHH SI-1657-1988. Not suitable for use in shot blasting cabinets.

<b>Weight:</b>	6 x 700g
<b>Container:</b>	Bottle

**C**

**25kg**



**C SEE BELOW**

**25kg Blasting Soda**

Soda will not etch glass and will not warp or remove metalwork. Leaves a rust inhibitor behind for up to six weeks.

Model No:	Size:	Container:
SBG25KG	285microns	Bag
BSBG25KG	285microns	Tub

**F**

**22kg**



**F SB993**

**Portable Shot Blasting Kit**

Compact and portable shot blasting kit. Large capacity hopper with convenient carry handle and wraparound hose storage. Supplied with 4.5m grit hose and fitted with a heavy-duty shot blasting gun.

<b>Maximum Fill Weight:</b>	22kg
<b>Operating Pressure:</b>	50-120psi
<b>Air Consumption:</b>	3.5cfm @ 50psi
<b>Inlet Size:</b>	1/4" BSP
<b>Weight:</b>	2.4kg

**G**







### A-B SEE BELOW Shot Blasting Kits

Compact and portable shot blasting kits. Large capacity hopper with handle and heavy-duty rubber wheels for easy manoeuvrability. Supplied with 3m grit hose, fitted with a heavy-duty shot blasting gun and four ceramic nozzles.

	A	B
Model No:	SB994	SB995
Maximum Fill Weight:	22.6kg	40kg
Operating Pressure:	60-125psi	60-125psi
Air Consumption:	10-16cfm	10-16cfm
Inlet Size:	1/4"BSP	1/4"BSP
Nozzle Sizes:	4, 5, 6, 7mm	4, 5, 6, 7mm
Overall Dimensions (W x D x H):	330 x 370 x 685mm	432 x 458 x 940mm
Weight:	4.81kg	7.73kg



### C-D SEE BELOW

#### Shot Blasters with Water Trap & Wheels

Pressurised tanks for maximum power. Supplied with 2.4m rubber hose, five ceramic nozzles and in-line water trap for moisture-free grit blasting. Also includes bayonet air line coupling and airflow regulator. Both accept a variety of grits up to 700microns and are suitable for stripping rust and paint from wheels, chassis, panels and other corroded/painted surfaces.

	C	D
Model No:	SB997	SB998
Maximum Fill Weight:	46kg	92kg
Operating Pressure:	60-125psi	60-125psi
Air Consumption:	6-25cfm	6-25cfm
Inlet Size:	1/4"BSP	1/4"BSP
Nozzle Sizes:	2, 2.5, 3, 3.5, 5mm	2, 2.5, 3, 3.5, 5mm
Grit Size:	700microns	700microns
Maximum Grit Consumption:	180kg/hr	180kg/hr
Weight:	17.68kg	23.60kg



### E SBKITA Shot & Soda Blasting Kit

For full specification refer to the individual Model No's.

Contents:	SB997, SB99.KIT, SSP141, SBG25KG, B/25KG
-----------	--



### F PSB05 Portable Soda Blasting Gun

Suitable for controlled removal of paint, mould, carbon, grease and rust. When adjusted correctly, is particularly useful in areas where less aggressive cleaning is required, such as around windows (without etching the glass) and even for stripping paint from wooden furniture. Suitable for use on food industry machinery, as soda-blasting is an A1 rated cleaning agent. Also inhibits rust on untreated surfaces for up to six weeks. Made of strong composite resin. Just add dry blasting soda into the container and connect to source of compressed air to use. Adjustable nozzle allows control from narrow to wider stream.

Nozzle Diameter:	Ø5mm
Operating Pressure:	75-115psi
Air Consumption:	8.5cfm @ 90psi

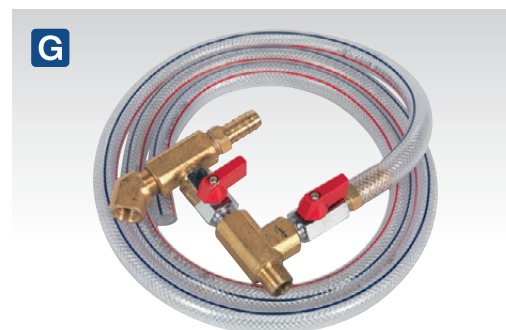

### G SB99.KIT Soda Blasting Conversion Kit for SB997 & SB998

Soda blasting accessory for use in conjunction with Model No's SB997 and SB998 Shot Blasters. Quick and simple to fit and use. Soda blasting is especially suitable in the classic car market as soda will not etch glass and will not warp or remove metalwork. Surface will be left smooth. Soda also leaves a rust inhibitor behind for up to six weeks.





**A SB951**  
**Shot Blasting Cabinet with Gun**

Steel cabinet with replaceable viewing screen and internal illumination. Fitted with shot blasting gun and suitable for proprietary brands of glass beads, silicon carbide, aluminium oxide and silica sand only. Excellent for a wide variety of workshop and bodyshop cleaning applications. Requires a standard, dry workshop air supply. Supplied assembled and ready for use.

Operating Pressure:	90psi
Air Consumption:	12cfm
Inlet Size:	1/4" BSP
Overall Dimensions (W x D x H):	640 x 490 x 490mm
Doors:	1
Door Size:	530 x 440mm
Viewing Area:	490 x 395mm



**B SB970**  
**Shot Blasting Cabinet with Gun Double Access**

Heavy-duty steel cabinet with toughened glass viewing screen and integral low voltage illumination. Two large side doors provide easy-access for bulkier items. Includes Ø34mm dust extraction port for a clear view. Heavy gauntlets provide hand protection and cabinet is supplied with sand blasting gun with three spare ceramic nozzles. Suitable for glass beads, silica sand, aluminium oxide and other proprietary brands of blasting media. Includes pack of 10 screen covers.

Operating Pressure:	60-85psi
Air Consumption:	10cfm
Inlet Size:	1/4" BSP
Overall Dimensions (W x D x H):	695 x 580 x 625mm
Doors:	2
Door Size (W x H (Min./Max.)):	525 x 240/430mm
Viewing Area:	485 x 275mm



**C SB972**  
**Shot Blasting Cabinet**

Steel cabinet with replaceable viewing screen and internal illumination. Fitted with shot blasting gun and suitable for proprietary brands of glass beads, silicon carbide, aluminium oxide and silica sand only. Excellent for a wide variety of workshop and bodyshop cleaning applications. May either be bench mounted or floor mounted on the optional stand Model No. SB972/ST. Requires a standard, dry workshop air supply. Supplied assembled and ready for use.

Operating Pressure:	80psi
Air Consumption:	13cfm
Inlet Size:	1/4" BSP
Overall Dimensions (W x D x H):	760 x 510 x 715mm
Doors:	1
Door Size:	710 x 350mm
Viewing Area:	570 x 270mm
Optional Accessories:	SB972/ST



**D-E SEE BELOW**  
**Shot Blasting Cabinets**

Heavy-duty steel cabinets with toughened glass viewing screen and integral low voltage illumination. Double side doors on Model No. SB974 provide easy-access for bulkier items. Includes dust extraction port. Heavy gauntlets provide hand protection and each cabinet is supplied with sand blasting gun, four ceramic nozzles and a pack of screen covers. Suitable for glass beads, silicon carbide, aluminium oxide and shot blasting grit only.

	<b>D</b>	<b>E</b>
Model No:	SB973	SB974
Operating Pressure:	90psi	60-120psi
Air Consumption:	15cfm	15cfm
Inlet Size:	1/4" BSP	1/4" BSP
Overall Dimensions (W x D x H):	890 x 570 x 1380mm	960 x 720 x 1500mm
Doors:	1	2
Door Size (W x H (Min./Max.)):	480 x 245/410mm	580 x 320/495mm
Extraction Port Diameter:	Ø60mm	Ø64mm
Viewing Area:	570 x 270mm	580 x 270mm



**F SB972/ST**  
**Stand for SB972**

Floor stand for use with Model No. SB972 Shot Blasting Cabinet.

Weight:	10.75kg
---------	---------



All models feature integral low voltage lighting and are supplied with either a shot or sand blasting gun. Model No's SB970 and SB974 are equipped with two doors to give easier access for bulkier items.