

# JANITORIAL, MATERIAL HANDLING & LEISURE

[back to  
Section List](#)



**Auger**  
1344

**Cleaning Accessories**  
1312-1313

**Janitorial Trolley**  
1328

**Bicycle Racks & Stands**  
1383

**Dust Suppression Water Tanks**  
1339

**Ladders**  
1348-1352

**Broadcast Sprayers**  
1341

**Flexi-Tubs**  
1339

**Levelling Ramps**  
1380

**Brushes & Brooms**  
1324-1325

**Floor Sweepers**  
1324

**Loft Ladder**  
1350

**Bungee Cords**  
1375-1376

**Geared Winches**  
1363

**Log Splitters**  
1344-1345

**Car Covers**  
1384

**Grit/Salt Boxes**  
1343

**Mops & Buckets**  
1327-1328

**Car Port Shelters**  
1385-1387

**Heated Jackets**  
1388

**Pallet Trucks**  
1368

**Cigarette Bins**  
1332

**Hydraulic Platform Trucks**  
1374

**Platform Trucks**  
1373

## Platforms & Steps

1352-1353

## Scaffold Towers

1355

## Transport Dollies

1369

## Pond Pumps

1338

## Shovels

1342-1343

## Vacuum Cleaners

1316-1323

## Post Driver

1344

## Sprayers

1347

## Valeting Machines

1323

## Pressure Washers

1304-1311

## Spreaders

1340-1341

## Vehicle Locks & Clamps

1381

## Ratchet Power Pullers

1362

## Squeegees & Scraper

1326

## Warehouse Steps

1354

## Ratchet Straps

1375-1379

## Steam Cleaner

1313

## Water Hoses & Reels

1314-1315

## Recovery Winches

1364-1366

## Submersible Water Pumps

1334-1336

## Water Pumps

1334-1337

## Refuse Bins

1329

## Tarpaulins

1376

## Wheelbarrows

1339

## Sack Trucks

1369-1372

## Tow Ropes & Poles

1367

## Wheelie Bins

1330-1331

## Safety Barriers

1382

## Towing Accessories

1356-1361

## Workshop Matting

1333

## Trailer Boards

1359



**A PW1601**

**110bar Pressure Washer with TSS & Accessory Kit**

Lightweight, powerful entry level unit designed for domestic and light trade use. Ideal for a range of applications including cleaning vehicles, patios, decking, motorbikes and barbecues. Fitted with a powerful 1700W motor with 330L/hr flow and a maximum pressure output of 110bar. Features automatic Total Stop System (TSS), which switches the motor on and off when the trigger is operated, prolonging motor life. Fitted with accessory storage and hose/cable hook to ensure unit stays clutter-free and mobile. Supplied with 3m hose and full accessory kit including lance extension, patio brush, rotary brush, fixed brush and detergent bottle.

Hose Length:	3m
Maximum Pressure:	110bar(1600psi)
Motor Power:	1700W
Rated Pressure:	80bar(1160psi)
Rotablast® Nozzle:	✗
Supply/Plug Type:	230V/3-Pin
Power Supply Cable Length:	5m
Total Stop System:	✓
Water Flow:	330L/hr



**AUTOMATIC TOTAL STOP SYSTEM**  
330L/hr



**B NEW**



**B PWOSNA Snow Foam Sprayer for PW1601/PW1850**

For use with Pressure Washer Model No's PW1601 and PW1850 to apply snow foam. Includes variable nozzle and detergent regulator.



**C CP20VPW 20V Cordless Pressure Washer - Body Only**

Lightweight and portable cordless pressure washer. Ideal for cleaning muddy bikes and sports equipment, as well as gutters, conservatory roofs and other hard to reach places. 6-Function nozzles, selected by turning spray head. 120L/hr flow rate and a working pressure of 22bar. 6m Water intake hose with float and filter can draw water from any remote source. Supplied with soap pot. Requires compatible 20V battery and mains charger, sold separately. See pages 844 to 872 for the rest of the SV20 range.

Maximum Pressure:	22bar(320psi)
Maximum Water Flow:	120L/hr
Hose Length:	6m
Motor Power:	130W
Supply:	20V



+ BATTERY (2Ah)  
+ BATTERY CHARGER  
+ STORAGE BAG



+ BATTERY (2Ah)  
+ BATTERY (4Ah)  
+ BATTERY CHARGER  
+ STORAGE BAG

Model No:	Type:	Contents:
<b>C</b> CP20VPW	Body Only	Pressure Washer
<b>D</b> CP20VPWKIT1	Kit	CP20VPW - Pressure Washer CP20VBP2 - 2Ah Battery CP20VMC - Battery Charger CP1200CB - Canvas Storage Bag
<b>E</b> CP20VPWKIT	Kit	CP20VPW - Pressure Washer CP20VBP2 - 2Ah Battery CP20VBP4 - 4Ah Battery CP20VMC - Battery Charger CP1200CB - Canvas Storage Bag

**A PW1850**  
**130bar Pressure Washer**  
**with TSS & Rotablast® Nozzle**

Powerful unit designed for frequent domestic and light trade use. Fitted with a powerful 1900W carbon brush motor with 420L/hr water flow and a maximum pressure output of 130bar. Features automatic Total Stop System (TSS) which switches the motor on and off when the trigger is operated, prolonging motor life. Includes accessory storage to ensure unit stays clutter-free and fully mobile. Supplied with 4m hose, foam lance and bottle, variable spray nozzle and Rotablast® Turbo nozzle which helps develop the same effective cleaning power (ECP) as a 180bar/2600psi pressure washer.



**B PW2000PA**  
**140bar Pull Along Pressure Washer**  
**with TSS**

Lightweight and powerful entry level unit, designed for domestic and light trade use. Ideal for a range of applications including cleaning vehicles, patios, decking, motorbikes and barbecues. Fitted with a powerful 1800W carbon brush motor with 400L/hr water flow rate and a maximum pressure output of 140bar. Includes Total Stop System. Fitted with accessory storage to ensure unit stays clutter-free and mobile. Supplied with 5m hose, spray nozzle, lance and detergent bottle. Sits on two castor wheels and two fixed wheels for easy manoeuvrability.



	<b>A</b>	<b>B</b>
<b>Model No:</b>	PW1850	PW2000PA
<b>Hose Length:</b>	4m	5m
<b>Maximum Pressure:</b>	130bar(1885psi)	140bar(2030psi)
<b>Motor Power:</b>	1900W	1800W
<b>Rated Pressure:</b>	100bar(1450psi)	100bar(1450psi)
<b>Rotablast® Nozzle:</b>	✓	✗
<b>Supply/Plug Type:</b>	230V/3-Pin	230V/3-Pin
<b>Power Supply Cable Length:</b>	5m	5m
<b>Total Stop System:</b>	✓	✓
<b>Water Flow:</b>	420L/hr	400L/hr

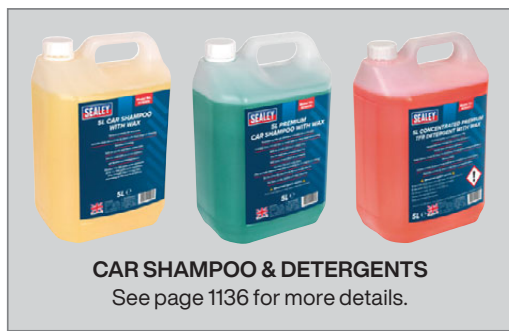



**A PW2400**

**170bar Pressure Washer - Lance Controlled Pressure with TSS & Rotablast® Nozzle**

Features lance controlled pressure adjustment with three power settings. Low power for soft cleaning, Medium power for vehicles and High power for patio and brickwork. Quick release nozzle system allows for fast selection between fan and Rotablast® nozzle. Pressure gun includes lock to avoid accidental activation. 2400W motor produces up to 170bar of pressure with an impressive 450L/hr flow rate. Automatic Total Stop System (TSS) which switches the motor on and off when the trigger is operated, prolonging motor life. 5m Inline pressurised hose reel and heavy-duty wheels for ease of use. Built-in detergent tank that filters into the jet stream perfect for use with the Low power mode with no need to change the lance. Supplied with 5m power cable for extended reach and snow foam/detergent sprayer.

Hose Length:	5m
Maximum Pressure:	170bar(2350psi)
Motor Power:	2400W
Rated Pressure:	120bar(1740psi)
Rotablast® Nozzle:	✓
Supply/Plug Type:	230V/3-Pin
Power Supply Cable Length:	5m
Total Stop System:	✓
Water Flow Rate:	6.5/7.5L/min



**B PW1610**

**100bar Pressure Washer with TSS & Rotablast® Nozzle**

Ideal for cleaning vehicles, machinery, as well as patios and other outdoor surfaces. Quick release nozzle system allows for fast selection between fan and Rotablast® nozzle. Pressure gun includes lock to avoid accidental start. 1200W motor produces up to 100bar of pressure with an impressive 390L/hr flow rate. Automatic Total Stop System (TSS) which switches the motor on and off when the trigger is operated, prolonging motor life. Self-priming motor can be used with a still water source for maximum portability. Supplied with 5m pressurized hose for ease of use, 5m power cable for extended reach and snow foam/detergent sprayer.

Hose Length:	5m
Maximum Pressure:	100bar(1450psi)
Motor Power:	1200W
Rated Pressure:	70bar(1015psi)
Rotablast® Nozzle:	✓
Supply/Plug Type:	230V/3-Pin
Power Supply Cable Length:	5m
Total Stop System:	✓
Water Flow Rate:	5.5L/6.5L/min



**C PW1860**

**130bar Pressure Washer with TSS & Rotablast® Nozzle**

Ideal for cleaning vehicles, machinery, as well as patios and other outdoor surfaces. Quick release nozzle system allows for fast selection between fan and Rotablast® nozzle. Pressure gun includes lock to avoid accidental activation. 1600W Motor produces up to 130bar of pressure with an impressive 420L/hr flow rate. Automatic Total Stop System (TSS) which switches the motor on and off when the trigger is operated, prolonging motor life. Self-priming motor can be used with a still water source for maximum portability. Supplied with 5m pressurized hose reel for ease of use, 5m power cable for extended reach and snow foam/detergent sprayer.

Hose Length:	5m
Maximum Pressure:	130bar(1885psi)
Motor Power:	1600W
Rated Pressure:	90bar(1305psi)
Rotablast® Nozzle:	✓
Supply/Plug Type:	230V/3-Pin
Power Supply Cable Length:	5m
Total Stop System:	✓
Water Flow Rate:	6L/7L/min



**A-B SEE BELOW**

**Pressure Washers with TSS & Rotablast® Nozzle**

Fitted with heavy-duty induction motors and improved pumps, these units are designed for regular domestic and light trade use. Both units are supplied with variable spray lance and Rotablast® Nozzle. Model No. PW2200 is fitted with innovative selectable dual detergent tank, ideal for applying multiple cleaning agents. Both models are fitted with cable and lance storage.

	<b>A</b>	<b>B</b>
<b>Model No:</b>	PW2200	PW2500
<b>Maximum Pressure:</b>	140bar(2030psi)	170bar(2350psi)
<b>Effective Cleaning Power:</b>	257bar(3727psi)	275bar(3995psi)
<b>Water Flow:</b>	400L/hr	438L/hr
<b>Detergent Tank:</b>	Dual	Single
<b>Motor Power:</b>	1800W	2500W
<b>Supply/Plug Type:</b>	230V/3-Pin	230V/3-Pin
<b>Power Supply Cable Length:</b>	5m	5m
<b>Total Stop System:</b>	✓	✓
<b>Rotablast® Nozzle:</b>	✓	✓
<b>Hose Length:</b>	5m	5m
<b>Weight:</b>	17.2kg	19.7kg



**C PWA01**  
Variable Lance for PW2200 & PW2500



**D PWA02**  
Rotablast® Lance for PW2200 & PW2500



**E PWA03**  
Fixed Brush for PW2200 & PW2500



**F PWA04**  
Rotary Brush for PW2200 & PW2500



**G PWA05**  
Floor Brush with Detergent Tank for PW2200 & PW2500



**H-I SEE BELOW**

**Professional Pressure Washers**

Professional units designed in Italy. Perfect for rigorous daily use in domestic, trade and commercial environments. These units are manufactured using top quality components. Model No. PW3500 is fitted with innovative accessory storage on the rear of the unit. Model No. PW5000 is supplied with five interchangeable nozzles. Both models are fitted with hose reels, built-in detergent tanks and heavy-duty wheels.

	<b>H</b>	<b>I</b>
<b>Model No:</b>	PW3500	PW5000
<b>Maximum Pressure:</b>	140bar(2050psi)	150bar(2200psi)
<b>Effective Cleaning Power:</b>	240bar(3485psi)	n/a
<b>Water Flow:</b>	420L/hr	498L/hr
<b>Motor Power:</b>	2100W	2500W
<b>Supply/Plug Type:</b>	230V/3-Pin	230V/3-Pin
<b>Power Supply Cable Length:</b>	5m	5m
<b>Total Stop System:</b>	✓	✓
<b>Rotablast® Nozzle:</b>	✓	✗
<b>Hose Length:</b>	8m	10m
<b>Nozzles:</b>	Pencil, Fan	Pencil, Fan; 15°, 25°, 40°, Low Pressure
<b>Weight:</b>	18.8kg	33.2kg



**J PWA07**  
Fixed Brush for PW3500 & PW5000



**K PWA06**  
Rotary Brush for PW3500 & PW5000



**L PWA10**  
Water Suction Kit for PW3500 & PW5000



## A PWT2200

### 150bar Pressure Washer - Twin Pump with TSS & Rotablast® Nozzle

Features two pumps and twin nozzle for up to 70% faster cleaning. Eco Soft cleaning mode only activates one pump for light use. Fast cleaning mode activates both pumps together and, with the twin flow nozzle, gets rid of the toughest dirt and stains. Quick release nozzle system allows fast selection between single or twin nozzle. Fitted with two 1250W motors with total 810L/hr water flow rate and a maximum pressure output of 150bar. Features automatic Total Stop System (TSS) which switches the motor on and off when the trigger is operated, prolonging motor life. Supplied with 8m high pressure hose and reel, detergent bottle, 5m power cable and heavy-duty wheels.

Maximum Pressure:	150bar(2200psi)
Water Flow:	810L/hr(Max.)
Motor Power:	2500W
Supply/Plug Type:	230V/3-Pin
Power Supply Cable Length:	5m
Total Stop System:	✓
Hose Length:	8m
Weight:	13.95kg
Rotablast® Nozzle:	✓



Quick release for switching between single or twin nozzle.

TWIN NOZZLE  
**+70%  
FASTER**



## A



**ROTABLAST®  
NOZZLE**

AUTOMATIC  
TOTAL STOP  
SYSTEM

810L/hr

High Flow



### Dual Pump Power Cleaning System



Oversized power control dial allows easy selection between Eco Soft and Fast Cleaning.

**1  
Pump**

Eco Soft  
Cleaning



**2  
Pumps**

Fast  
Cleaning



## B PWDM3600

### 290bar Pressure Washer 10hp Diesel

Diesel powered with electric and recoil starting. Offers high pressure and high flow with diesel economy. Ideal for commercial applications with 5m pressure hose, 1m gun and lance and five interchangeable nozzles. Low pressure liquid detergent injection system. Safety latch on trigger, automatic low oil engine shutdown and thermal pump relief valve reduce risk of misuse and equipment damage. Pneumatic tyres.

Manifold Pressure:	250bar(3625psi)
Maximum Pressure:	290bar(4205psi)
Flow Rate:	900L/hr
Hose Length:	5m
Nozzles:	0°, 15°, 25°, 40° Fan & Detergent
Maximum Inlet Temperature:	50°C
Engine Type:	4-Stroke, Single Cylinder, Diesel
Engine Capacity:	418cc
Engine Power:	10hp
Starting:	Recoil/Electric
Fuel Tank:	7L
Fuel Consumption:	1.7-2.3L/hr
Noise Level:	116dB(A)
Weight:	100kg



Diesel tank.



Detergent suction hose.



Exhaust.

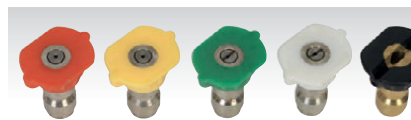

PWDM3600 is supplied with five interchangeable nozzles.



900L/hr

**B**

10hp

**75+ KG  
HEAVY ITEM**





**A**  
360L/hr  
4hp

**A PWM1300**  
**150bar Pressure Washer**  
**360L/hr 4hp Petrol**

Petrol powered pressure washer with recoil starting. Suitable for commercial and domestic applications with 5m pressure hose, gun, lance and adjustable nozzle. Low-pressure liquid detergent injection system. Safety latch on trigger. Unit stands on two sucker feet to prevent movement and two wheels for easier mobility with an integral handle.

Manifold Pressure:	110bar(1595psi)
Maximum Pressure:	150bar(2175psi)
Flow Rate:	360L/hr
Hose Length:	5m
Nozzle:	Adjustable
Maximum Inlet Temperature:	40°C
Engine Type:	4-Stroke, Single Cylinder, Petrol
Engine Capacity:	141cc
Engine Power:	4hp
Starting:	Recoil
Fuel Tank:	1L
Fuel Consumption:	0.8-1L/hr
Weight:	20kg



**B**  
540L/hr  
6.5hp

**B PWM2500**  
**220bar Pressure Washer**  
**540L/hr 6.5hp Petrol**

Petrol powered pressure washer with recoil starting. Ideal for commercial applications with 5m pressure hose, 1m gun and lance and interchangeable nozzles. Low-pressure liquid detergent injection system. Safety latch on trigger and automatic low oil engine shutdown reduce risk of misuse and equipment damage. Mounted in robust frame fitted with two sucker feet and two wheels for stability and easy mobility.

Manifold Pressure:	175bar(2538psi)
Maximum Pressure:	220bar(3190psi)
Flow Rate:	540L/hr
Hose Length:	5m
Nozzles:	0°, 15°, 25°, 40° Fan & Detergent
Maximum Inlet Temperature:	50°C
Engine Type:	4-Stroke, Single Cylinder, Petrol
Engine Capacity:	196cc
Engine Power:	6.5hp
Starting:	Recoil
Fuel Tank:	4L
Fuel Consumption:	2.1-2.6L/hr
Weight:	35kg



**C**  
540L/hr  
6.5hp

**C PWM2500SP**  
**220bar Pressure Washer 540L/hr**  
**Self-Priming 6.5hp Petrol**

Petrol powered pressure washer with recoil starting. Ideal for commercial applications with 5m pressure hose, pick-up hose, 1m gun and lance and five interchangeable nozzles. Features a professional level triplex plunger pump with brass head boasting high efficiency, high pressure output and longevity. Self-priming pump and pick-up hose with filter allows for any reservoir pick-up, to allow use where no mains pressure is available. Low-pressure liquid detergent injection system fed from two easily switchable 2.25L tanks allowing for continuous alternate applications without the need to empty/refill. Safety latch on trigger and automatic low-oil engine shutdown reduce risk of misuse and equipment damage. Mounted in robust frame fitted with two sucker feet and two wheels for stability and easy mobility.

Manifold Pressure:	175bar(2538psi)
Maximum Pressure:	220bar(3190psi)
Flow Rate:	540L/hr
Hose Length:	5m
Nozzles:	0°, 15°, 25°, 40° Fan & Detergent
Maximum Inlet Temperature:	50°C
Engine Type:	4-Stroke, Single Cylinder, Petrol
Engine Capacity:	196cc
Engine Power:	6.5hp
Starting:	Recoil
Fuel Tank:	4L
Fuel Consumption:	2.1-2.6L/hr
Weight:	40kg



**D SCS003**  
**5L Concentrated General-Purpose**  
**TFR Detergent with Wax**

See page 1136 for more information.



**B & C**



PWM2500 & PWM2500SP are supplied with five interchangeable nozzles.



**A**



**Induction Motor**

**Hot & Cold Water**

**230V**

**420L/hr**

**AUTOMATIC TOTAL STOP SYSTEM**

**MADE IN ITALY**



Control panel.



Diesel tank.



Heat exhaust.

**A**



**A PW2000HW**

**135bar Hot/Cold Water Pressure Washer 230V**

Professional, heavy-duty hot/cold water pressure washer. Ideal for a range of applications including cleaning vehicles, commercial equipment, motorbikes, patios and decking. Fitted with a heavy-duty, upgraded induction electric motor with a diesel water heater. Double motor (pump and burner) with three high durability steel pistons and aluminium axial pump. Vertical boiler with high efficiency steel coil and safety valve. Automatic temperature regulation. Detergent tank is built-in for direct suction. Features an automatic Total Stop System (TSS) which switches the motor and heater on and off when the lance trigger is operated, prolonging the motor life. Manufactured with heavy-duty plastic wheels for transportation over rough terrain.

Effective Cleaning Power:	135bar(1958psi)
Flow Rate:	420L/hr
Motor Power:	2300W
Supply/Plug Type:	230V/3-Pin
Power Supply Cable Length:	6m
Heating Fuel:	Diesel
Hose Length:	8m
Peak Water Temperature:	80°C
Weight:	41kg

**B**

**AUTOMATIC TOTAL STOP SYSTEM**

**MADE IN ITALY**

**540L/hr**

**75+ KG HEAVY ITEM**



**Induction Motor**

**Hot & Cold Water**



**230V**



**B PW2500HW**

**170bar Hot Water Pressure Washer 230V**

Professional, heavy-duty hot/cold water pressure washer. Ideal for a range of applications including cleaning vehicles, commercial equipment, motorbikes, patios and decking. Fitted with a heavy-duty, upgraded induction electric motor with a diesel water heater. Double motor (pump and burner) with three high durability ceramic coated pistons and aluminium axial pump. Automatic temperature regulation. Detergent tank is built-in for direct suction. Features an automatic Total Stop System (TSS) which switches the motor and heater on and off when the lance trigger is operated, prolonging the motor life. Manufactured with heavy-duty plastic wheels for transportation over rough terrain.

Effective Cleaning Power:	170bar(2465psi)
Flow Rate:	540L/hr
Motor Power:	3000W
Motor:	Induction
Supply/Plug Type:	230V/3-Pin
Power Supply Cable Length:	6m
Heating Fuel:	Diesel
Hose Length:	5m
Pump Head:	Ceramic Coated
Peak Water Temperature:	80°C
Weight:	76.74kg





**A**



**AUTOMATIC TOTAL STOP SYSTEM**

**12V**  
**36W**  
**180L/hr**

**A PW12CC**

**12V Portable Pressure Washer Self-Priming Cleaning Kit in Storage Case**

Lightweight, portable pressure washer with self-priming submersible pump, supplied in a storage case. Ideal for many washing applications, especially where mains power or water supply is not available, such as car shows, track days, window cleaning or even garden use. Features automatic Total Stop System (TSS) which switches the motor on and off when the trigger is operated, prolonging motor life. Unit is powered using a 4.8m cable fitted with a 12V vehicle accessory socket plug. Supplied with 8m hose, variable nozzle lance, detergent bottle and a long fixed brush.

Maximum Pressure:	9bar(131psi)
Water Flow Rate:	180L/hr
Motor Power:	36W
Supply:	12V
Hose Length:	8m
Weight:	3.1kg

**B**



**Lithium RECHARGEABLE**

**12V**  
**36W**

**AUTOMATIC TOTAL STOP SYSTEM**

**180L/hr**



For illustrative purposes only.

**B PW2012R**

**25L 12V Rechargeable Pressure Washer**

Rechargeable, lightweight, portable pressure washer which can hold up to 25L of water. Ideal for use where a mains power or water supply is not available, such as car shows, track days, window cleaning or even garden use. Inside is a removable storage tray to accommodate all the accessories. Supplied with 8m hose, variable nozzle lance, detergent bottle and a long fixed brush. Detergent can also be added to the main tank. Fitted with four wheels, which makes the unit easy to transport. Fitted with a strong carry handle. Supplied with mains charger and 12V in car charger.

Capacity:	25L
Battery Type:	12V 4Ah Lithium-ion
Maximum Pressure:	9bar(131psi)
Water Flow Rate:	180L/hr
Motor Power:	36W
Supply:	12V
Hose Length:	8m
Charging Time:	3hr
Operating Time:	2.5hr
Weight:	4.5kg

**C**



**AUTOMATIC TOTAL STOP SYSTEM**

**12V**  
**36W**  
**180L/hr**

**C PW2512**

**25L 12V Pressure Washer**

Lightweight, portable pressure washer which can hold up to 25L of water. Ideal for use where a mains power or water supply is not available, such as car shows, track days, window cleaning or even garden use. Unit is powered using a 3m cable fitted with a 12V vehicle accessory socket plug. Supplied with 8m hose, variable nozzle lance, detergent bottle and a long fixed brush. Detergent can also be added to the main tank. Fitted with a strong carry handle.

Capacity:	25L
Maximum Pressure:	9bar(131psi)
Water Flow Rate:	180L/hr
Motor Power:	36W
Supply:	12V
Hose Length:	8m
Weight:	3.1kg

**D**



**12V**

**150L/hr**

**60W**

**Rechargeable**



**D PW1712**

**17L 12V Rechargeable Pressure Washer**

Lightweight, cordless pressure washer. Ideal for a range of domestic applications including cleaning vehicles, motorcycles and bicycles. Features 17L water tank which can be detached from base for easy refilling. Unit can be powered using vehicle's 12V socket, but is also fitted with a rechargeable lead acid battery which provides up to 40 minutes of continuous use. Ideal pressure washer where no mains electric supply is available, such as classic car shows and track days. Supplied with 6m hose, variable nozzle and fixed brush, both of which include built-in detergent bottles. Fitted with accessory storage pouch, durable wheels and shoulder strap for easy transportation.

Capacity:	17L
Battery Type:	Lead Acid
Maximum Pressure:	8.5bar(123psi)
Water Flow Rate:	150L/hr
Motor Power:	60W
Supply:	12V
Hose Length:	6m
Charging Time:	6hr
Operating Time:	20-40min
Weight:	6.8kg



**A WCP10**  
**10L Plastic Watering Can**  
 Strong and durable 10L plastic watering can with easy carry handle for greater flow control. Includes detachable rose.



**B CC64**  
**Large Sponge**  
 General-purpose bone-shaped sponge.



**C CC52**  
**Long Handle Dip & Wash Brush**  
 Fine, split-top bristles gently loosen and brush away dirt. Does not mark expensive clear coats or painted finishes. Long handle for access to hard-to-reach areas.



**D CC76**  
**2-in-1 Shaggy Microfibre Sponge**  
 Double-sided sponge with shaggy microfibre strands on one side, which are superb for removing dirt or general cleaning. Non-abrasive mesh cloth on the other side, ideal for removing bugs and obstinate grime.



**E CC77**  
**2-in-1 Shaggy Microfibre Mitt**  
 Double-sided mitt with shaggy microfibre strands on one side, which are superb for removing dirt or general cleaning. Non-abrasive mesh cloth on the other side, ideal for removing bugs and obstinate grime.



**F CBC01**  
**Microfibre Clay Bar Cloth**  
 Clay backed microfibre cloth designed as an alternative to clay bar detailing. Perfect for removing surface contaminants such as tree sap, rain stains, light rust, pollen, and bugs leaving a smooth finish to your paint. High quality materials allow for extended use compared to using a regular clay bar. Designed for use with clay bar lubricants.

**Size:** 300 x 300mm



**G CC61**  
**Large Interior Brush**  
 Sturdy bristles scrub away stains from upholstery, floor mats and vinyl tops. Angled design to reach corners easily. Contoured rubber grip for added comfort and control.

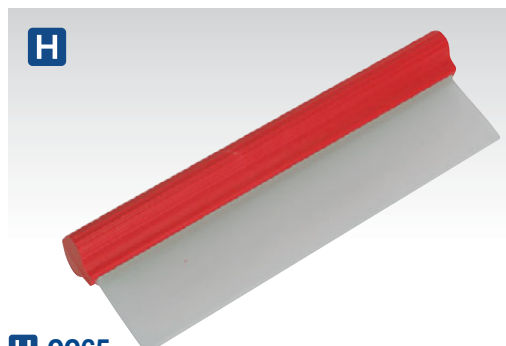

**H CC65**  
**Aqua Flexi-Blade**  
 Cuts drying time in half by removing excess water.

**Blade Length:** 300mm



**I CC71**  
**Sheen Microfibre Cloth**  
 Attracts, holds and lifts dust from any surface. Double-sided cloth, particularly suitable for car interiors.

**Size:** 400 x 400mm



**J CC68**  
**Forta Microfibre Cloth**  
 Developed by professional detailers for fast removal of dust and wax from the car surface. Ultra-fine fibres attract, lift and hold dirt, dust and grease with just a little water.

**Size:** 400 x 400mm



**K-L SEE BELOW**  
**Genuine Chamois**  
 Superior professional product, cut, conditioned, sized and 100% cod oil tanned. Supple and will leave surfaces lint and scratch-free.

<b>Model No:</b>	<b>Size:</b>
<b>K CC72</b>	2.5ft <sup>2</sup>
<b>L CC73</b>	3.5ft <sup>2</sup>



**M CC92**  
**PVA Chamois 2.5ft<sup>2</sup>**  
 Absorbs water to remove residue and streaks for a spotless finish. 100% Machine washable to clean and reuse.



**A VMSC01**

**2000W Steam Cleaner 1.8L Tank**

Ideal for small but stubborn stains. Using only tap water, this unit produces pressurized steam up to a maximum of 160°C, which cleans, sanitizes and sterilizes. Heats up to full temperature in only 8 minutes. Steam leaves no toxic residues as opposed to chemical cleaning. Includes a variety of accessories for multiple cleaning tasks. This machine is excellent for cleaning carpets and upholstery, alloy wheels, car interiors, floors, mirrors, glazed areas, service and toilet areas.

Power:	2000W
Tank Capacity:	1.8L
Maximum Operating Temperature:	160°C
Warm Up Time:	8min
Maximum Working Pressure:	5bar(72.5psi)
Supply/Plug Type:	230V/3-Pin
Power Supply Cable Length:	5m

**Accessories:** 2pc Extension Tube, Floor Scrub Brush, Floor Scrub Brush Cleaning Cloth, Floor Scrub Brush Adaptor, Small Tip Adaptor, Medium Brush, Small Brush, Small Power Jet Tip - Angled, Rotating Brush, Window Squeegee, Cloth for Window Squeegee, Wave Brush, Funnel & Measuring Jug

**A**

2000W

1.8L Capacity



**B NEW**



**B SDC01**

**Drain Unblocker**

Hand-fed 7.6m hand-fed coiled wire rod with rotating handle to clear stubborn blockages and residue. Locking mechanism retains wire rod once fed back into unit. Ø14mm Tip and Ø6mm rod ideal for clearing of small diameter pipework as well as sinks, showers, baths and drains.

**C NEW**

**Lithium RECHARGEABLE**



**C SCSG2R**

**2L Rechargeable Pressure Sprayer**

For full product information see page 1134.

**D**



**D SCSG08**

**Premier Industrial Disinfectant/Foam Pressure Sprayer**

For full product information see page 1134.

**E**



Telescopic 0.9-1.7m

Replacement Brush Head available, Model No. CC50BH

**E CC50**

**1.7m Large Angled Flo-Thru Brush with Telescopic Handle**

Manufactured from tough, lightweight structural plastic that will not crack, bend or break. Super-soft synthetic bristles are safe to use on any surface. Leak resistant aluminium handle with flo-thru feature gives fast and thorough cleaning.

Handle Extension:	900-1700mm
Replacement Flo-Thru Brush Head:	CC50BH

**F**



Telescopic 1.3-3m

Replacement Brush Head available, Model No. CC953BH

**F CC953**

**3m 5-Sided Flo-Thru Brush with Telescopic Handle**

Manufactured from tough, lightweight structural plastic that will not crack, bend or break. Telescopic handle extends up to 3m. 5-Sided brush head for all-over coverage, prevents potential damage from objects butting up against the plastic brush head. Super-soft synthetic bristles are safe to use on any surface. Leak resistant aluminium handle with flo-thru feature gives fast and thorough cleaning.

Handle Extension:	1300-3000mm
Replacement Flo-Thru Brush Head:	CC953BH



**A** 60m Capacity

Hose not included.

**A GH60**  
**Garden Hose Trolley 60m Capacity**

Lightweight tubular steel frame with tough plastic snap-together parts - no tools required. Fitted with two composite wheels for easy manoeuvrability and two angled 1/2" hose connectors. Reel holds up to 60m of Ø13mm hose.

<b>Hose Capacity:</b>	60m x Ø13mm
<b>Inlet/Outlet Diameter:</b>	Ø13mm
<b>Weight:</b>	2kg



**D**

**D CC79**  
**Water Spray Gun - 9 Pattern**

Soft rubber grip handle with locking trigger on/off switch. Rotating spray head gives nine different options - straight, jet, mist, shower, angle, flat horizontal, flat vertical, fan and tap.



**F**

**F SA928**  
**Water Dispensing Gun**

Connects to water hose for dispensing mains pressure water.

<b>Water Inlet Size:</b>	Ø1/2"
--------------------------	-------



**B NEW HEAVY DUTY**

Available Sizes

- 5m
- 15m
- 30m
- 50m

**B SEE BELOW**  
**Heavy-Duty Hose Reel Cart with Heavy-Duty Hot & Cold Rubber Water Hoses**

Includes a 1.8m leader hose with 3/4" BSP brass fittings. Fitted with easy-rolling 10" puncture proof PU wheels and solid axle for rough terrain. Lightweight hose constructed with high strength polyester braided reinforcement. Octagonal shaped hose helps reduce kinking and increase abrasion resistance.

Model No:	Length:	Hose Ø:	High Pressure:
HRKIT5	5m	Ø19mm	500psi
HRKIT15	15m	Ø19mm	500psi
HRKIT30	30m	Ø19mm	500psi
HRKIT50	50m	Ø19mm	500psi



**E**



**C HEAVY DUTY**

**C HRCHD**  
**Heavy-Duty Hose Reel Cart**

Lightweight and durable tubular steel design. Perfect for keeping longer water hoses neat and tidy. Includes a 1.8m leader hose with 3/4" BSP brass fittings. Can hold up to 120m of Ø13mm standard water hose or 50m of Ø19mm H/D hose (hose not included). Features a non-slip handle and a storage basket for frequently used tools. Fitted with easy-rolling 10" puncture proof PU wheels and solid axle for rough terrain.

<b>Weight:</b>	18.5kg
----------------	--------



**E**

**E CC86**  
**Water Spray Gun**

Manufactured from lightweight plastic with soft rubber grip handle. Features two adjustable pressure settings and flow rate control nozzle. Fitted with male inlet coupling.



**G**

Available Sizes

- 5m
- 15m
- 30m
- 50m

**HEAVY DUTY**

**G SEE BELOW**  
**Heavy-Duty Hex Hot & Cold Rubber Water Hoses**

Lightweight hose constructed with high strength polyester braided reinforcement for extreme durability. Suitable for all agricultural and workshop applications and designed to remain flexible in extreme conditions from -40°C to 90°C. High flow Ø19mm hexagonal hose can handle hot water up to 90°C, making it ideal for livestock and farming applications. Fitted with 3/4" BSP brass fittings to fit conventional water outlets. High pressure rating of 500psi.

Model No:	Length:	Hose Diameter:
HWH5M	5m	Ø19mm
HWH15M	15m	Ø19mm
HWH30M	30m	Ø19mm
HWH50M	50m	Ø19mm



**A NEW**



Available Sizes

15m

30m

**A SEE BELOW**

**Water Hose with Fittings**

Expandable hose which can be stored away with ease. Latex material increases the strength and durability. Weave design prevents tears when under tension. Supplied with brass fittings that can stop the build-up of rust, and stop the hose from cracking, leaking or corroding. Spray nozzle features comfortable trigger and handle as well as 10 different settings to suit a variety of tasks.



Model No:	Length:	Hose Diameter:
GH15E	15m	Ø17mm
GH30E	30m	Ø19mm

**B**

Available Sizes

15m

30m

80m



**B SEE BELOW**

**Water Hose with Fittings**

Polyester fibre reinforced 3-ply construction for added strength. Includes spray/jet nozzle, female connector, waterstop connector and threaded tap connector.

Model No:	Length:	Hose Diameter:
GH15R/12	15m	Ø12mm
GH30R	30m	Ø13mm
GH80R	80m	Ø13mm



**C**

**C**



20m

**C WR92**

**20m Water Hose Reel**

**Auto Layering**

Manufactured from durable lightweight material. Reinforced PVC hose with Ø13mm bore. Incorporates a soft grip handle for easy manoeuvrability or use preset holes for wall mounting. Suitable for use with pressure washers. Supplied with variable nozzle and tap connection.

Length:	20m
Hose Diameter:	Ø13mm

**D**

18m



**D RGH18**

**HEAVY DUTY**

**18m Retractable Water Hose Reel**

Heavy-duty durable composite case with carry handle. Fitted with 18m Ø12mm PVC hose with spray/jet nozzle. Heavy-duty ratchet mechanism enables safe storage and use. Supplied with wall mounting brackets.

Length:	18m
Hose Diameter:	Ø12mm

**E**

20m

30m



**Controlled Rewind**

**Auto Layering**

**Length Control**

**E SEE BELOW**

**Auto-Rewind Control Garden Hose Reels**

Composite housing with heavy-duty wall mounting swivel bracket. High quality Ø13mm PVC garden hose with spray/jet nozzle. Innovative design features three key points. Hose can be extended and stopped at any length. Controlled, slow rewind returns the water hose at a safe speed. Auto-layering mechanism distributes water hose evenly back into reel housing preventing it from jamming. Supplied with 2m leader hose with quick coupler and tap connector.

Model No:	Length:	Hose Diameter:
RWH20	20m	Ø13mm
RWH30	30m	Ø13mm

**F**



15m

Ø13mm ID

Steel Case

**HEAVY DUTY**

**F WHR1512**

**15m Heavy-Duty Retractable Water Hose Reel Ø13mm ID Rubber Hose**

Heavy-duty durable steel case. Fitted with heavy-duty 15m Ø13mm ultra-light, super-strong rubber hose with 2m leader hose. Features metal spray gun with nine pattern spray/jet nozzle. Finger grip bend restrictors for ease of use. Handles hot water up to 90°C and remains flexible in cold temperature as low as -40°C. Heavy-duty ratchet mechanism enables safe storage and use. Swivel wall mounting bracket included.

Hose Size (ID):	Ø13mm
Length:	15m





**A PC200A**  
**20L 3-in-1 Ash Vacuum Cleaner 1200W**  
 Ideal for the collection of ash or fire debris from fireplaces, stoves, wood burners, BBQs, grills and more. A powerful 1200W motor provides great suction performance whilst also acting as a blower. With a 20L capacity, the lightweight tank features quick release clips for ease of emptying. A 1.2m flexible metal lined suction hose allows the suction of ash up to a temperature of 40°C(100°F). Easily switch to blow function by using the outlet on the top of the vacuum. Features filter cleaning function by placing the end of the nozzle on the button at the top of the unit. Includes a HEPA filter with metal cover preventing the leaking of ash and dust and round aluminium nozzle. Cable length 2.5m. See table below for specification.

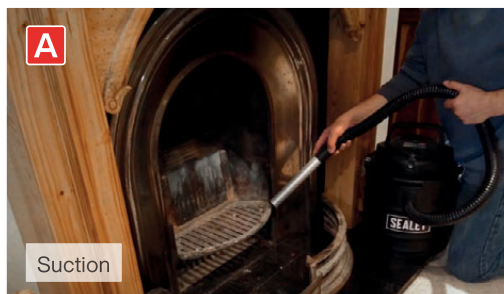

**B PC100**  
**10L 1000W Wet & Dry Vacuum Cleaner**  
 High powered, lightweight, wet and dry unit with blower facility. Constructed from high-impact composite material with tool and hose storage points on head. Ideal for vehicle cleaning and general workshop use. Supplied with crevice and floor tools, cloth and foam filters, 2.5m cable and 3-pin plug. See table below for specification.



**C PC102HV**  
**10L Wet & Dry Vacuum Cleaner 1000W**  
 High powered, lightweight, wet and dry unit with blower facility. Constructed from high-impact composite material with tool and hose storage points on head. Four castors to aid manoeuvrability. Ideal for vehicle cleaning, home cleaning and general workshop use. Supplied with crevice and floor tools, washable cloth filter, 3m cable and 3-pin plug. See table below for specification.

	<b>A</b>	<b>B</b>	<b>C</b>
Model No:	PC200A	PC100	PC102HV
Motor Power:	1200W	1000W	1000W
Supply/Plug Type:	230V/3-Pin	230V/3-Pin	230V/3-Pin
Maximum Vacuum Pressure:	160mbar	-	-
Airflow:	90m <sup>3</sup> /hr	90m <sup>3</sup> /hr	78m <sup>3</sup> /hr
Drum Size:	20L	10L	10L
Weight:	3.8kg	3.30kg	4.10kg
Vacuum Accessories Diameter:	Ø34mm	Ø35mm	Ø32mm
Filter Type:	Cartridge	Cloth & Foam	Cloth
Power Supply Cable Length:	2.5m	2.5m	3m
Replacement Cartridge Filter:	<b>D</b> PC200ACF	-	-
Washable Cloth Filter:	-	-	<b>E</b> PC102CF
Replacement Filter Bag:	-	<b>F</b> PC100.ACC4	-
Replacement Foam Filter:	-	<b>G</b> PC100.ACC2	-







**A PC200**

**20L Wet & Dry Vacuum Cleaner 1250W**

High powered, lightweight unit with blower facility. Constructed from high-impact plastic, the drum unit is mounted on two castor and two fixed wheels. Tool storage points on head and base. Supplied with 4m cable with 3-pin plug, tool kit, cartridge filter and wet-use foam filter.

Motor Power:	1250W
Supply/Plug Type:	230V/3-Pin
Power Supply Cable Length:	4m
Maximum Vacuum Pressure:	140mbar
Airflow:	120m <sup>3</sup> /hr
Drum Size:	20L
Weight:	5kg
Vacuum Accessories Diameter:	Ø35mm
Filter Type:	Cartridge
Replacement Cartridge Filter:	PC200CFL
Replacement Foam Filters (Pack of 10):	PC200FF10
Optional Dust Bags (Pack of 5):	PC200PB5



**B PC300**

**30L Wet & Dry Vacuum Cleaner 1100W**

High powered, lightweight unit with blower facility. Constructed from high-impact plastic, the drum unit is mounted on four castor wheels. Tool storage points on the base. Supplied with 4m cable with 3-pin plug, tool kit, wet and dry cartridge filter.

Motor Power:	1100W
Supply/Plug Type:	230V/3-Pin
Power Supply Cable Length:	4m
Maximum Vacuum Pressure:	165mbar
Airflow:	128m <sup>3</sup> /hr
Drum Size:	30L
Weight:	6.66kg
Vacuum Accessories Diameter:	Ø48mm
Filter Type:	Cartridge
D Replacement Cartridge Filter:	PC300V2CF
E Replacement Dust Bags (Pack of 10):	PC300V2DB



**C PC200CFF**

**Fine Dust Cartridge Filter**

Cartridge filter for fine particles down to 1micron. Suitable for use with PC200 Series.



**D PC300V2CF**

**Plastic Filter Cartridge for PC300.V2**

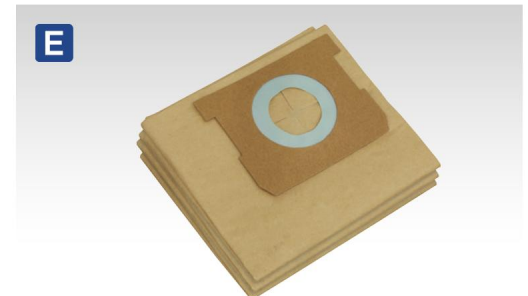

**E PC300V2DB**

**Dust Bag for PC300.V2 - Pack of 3**

**F GV180WM**

**1500W Wall Mounting Garage Vacuum with Remote Control**

Robust, wall mounting, remote control, wet and dry vacuum cleaner. Fitted with a powerful 1500W motor and noise diffuser, this unit is ideal for use in garage and workshop environments. Features an 8m spring hose, ideal for double garages. Also features remote control buttons on nozzle to allow the user to turn the unit on/off without leaving the cleaning area. Includes 5m power cable, extension lances (x2), combo brush, round brush, deluxe car nozzle, crevice tool, washable cartridge filter, foam filter and dust bag. Innovative design allows these accessories to be stored away, keeping your work area clean and tidy.

Motor Power:	1500W
Supply/Plug Type:	230V/3-Pin
Power Supply Cable Length:	5m
Maximum Vacuum Pressure:	165mbar
Airflow:	71.28m <sup>3</sup> /hr
Drum Size:	18L
Weight:	10.7kg
Vacuum Accessories Diameter:	Ø35mm
Filter Type:	Cartridge
Replacement Cartridge Filter:	GV180WM.27
Replacement Foam Filter:	GV180WM.26
Replacement Dust Bag:	GV180WM.18



Washable cartridge filter.



Remote control on nozzle.





**A-B SEE BELOW**

**1000W Low Noise Wet & Dry Vacuum Cleaners**

High powered, lightweight, wet and dry units with blower facility. Low noise motor reducing sound down to 80db. Constructed with a high impact metal drum and four castors to aid manoeuvrability. Ideal for vehicle cleaning, home cleaning and general workshop use. Supplied with crevice and floor tools, washable cloth filter, 4m cable and 3-pin plug.

	<b>A</b>	<b>B</b>
<b>Model No:</b>	PC20LN	PC30LN
<b>Motor Power:</b>	1000W	1000W
<b>Supply/Plug Type:</b>	230V/3-Pin	230V/3-Pin
<b>Power Supply Cable Length:</b>	4m	4m
<b>Maximum Vacuum Pressure:</b>	190mbar	190mbar
<b>Airflow:</b>	126m <sup>3</sup> /hr	120m <sup>3</sup> /hr
<b>Drum Size:</b>	20L	30L
<b>Vacuum Accessories Diameter:</b>	Ø35mm	Ø35mm
<b>Optional Accessories:</b>	Cloth Filter Cartridge - PCLNCF, Foam Filter Cartridge - PCLNFF, Dust Bag - PC20LNDB	Cloth Filter Cartridge - PCLNCF, Foam Filter Cartridge - PCLNFF, Dust Bag - PC30LNDB



**C PCLNCF**  
Cloth Filter Cartridge for PC20LN & PC30LN



**D-E SEE BELOW**  
Dust Bag - Packs of 5

Model No:	Application:
<b>D PC20LNDB</b>	PC20LN
<b>E PC30LNDB</b>	PC30LN

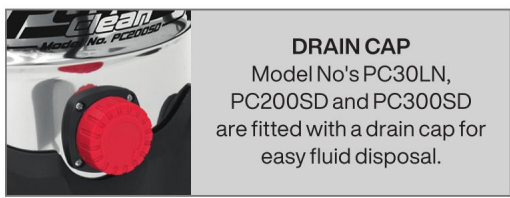

**DRAIN CAP**  
Model No's PC30LN, PC200SD and PC300SD are fitted with a drain cap for easy fluid disposal.



**F PC195SD**  
20L Wet & Dry Vacuum Cleaner  
1200W Stainless Drum

High powered, lightweight unit with blower facility. Constructed from stainless steel, the drum unit is mounted on four castor wheels. Tool storage points on head and base. Supplied with 4m cable, 3-pin plug and accessory tool kit, including three rigid extension tubes, wet-use foam filter and cloth filter.



**G PC200SD**  
20L Wet & Dry Industrial Vacuum Cleaner  
1250W Stainless Drum

High powered, lightweight industrial unit with blower facility. Constructed from stainless steel, the drum unit is mounted on two castor and two fixed wheels. Tool storage points on head and base. Supplied with 4m cable with 3-pin plug, deluxe tool kit, including stainless steel telescopic rigid extension tube, cartridge filter and wet-use foam filter.



**H PC300SD**  
30L Wet & Dry Industrial Vacuum Cleaner  
1400W Stainless Drum

High powered, lightweight industrial unit with blower facility. Constructed from stainless steel, the drum unit is mounted on two castor and two fixed wheels. Tool storage points on head and base. Supplied with 4m cable with 3-pin plug, deluxe tool kit, including stainless steel telescopic rigid extension tube, cartridge filter and wet-use foam filter.

	<b>F</b>	<b>G</b>	<b>H</b>
<b>Model No:</b>	PC195SD	PC200SD	PC300SD
<b>Motor Power:</b>	1200W	1250W	1400W
<b>Supply/Plug Type:</b>	230V/3-Pin	230V/3-Pin	230V/3-Pin
<b>Power Supply Cable Length:</b>	4m	4m	4m
<b>Maximum Vacuum Pressure:</b>	172mbar	140mbar	160mbar
<b>Airflow:</b>	126m <sup>3</sup> /hr	120m <sup>3</sup> /hr	120m <sup>3</sup> /hr
<b>Drum Size:</b>	20L	20L	30L
<b>Weight:</b>	5.5kg	5kg	7.4kg
<b>Vacuum Accessories Diameter:</b>	Ø32mm	Ø35mm	Ø35mm
<b>Filter Type:</b>	Cartridge	Cartridge	Cartridge
<b>Replacement Cartridge Filter:</b>	PC195SDCFL	PC200CFL	PC200CFL
<b>Replacement Foam Filters (Pack of 10):</b>	PC195SDF10	PC200FF10	PC200FF10
<b>Optional Dust Bags (Pack of 5):</b>	-	PC200PB5	PC300PB5



Accessory kit supplied with PC200SD, PC200SDAUTO, PC200SD110V, PC300SD and PC300SDAUTO.

The tubes supplied with PC200SD, PC200SDAUTO, PC200SD110V, PC300SD & PC300SDAUTO are extendable. Simply press the button and extend to desired length.





**A PC200SD110V**  
**20L Wet & Dry Industrial Vacuum Cleaner**  
**1250W/110V Stainless Drum**

High powered, lightweight industrial unit with blower facility. Constructed from stainless steel, the drum unit is mounted on two castor and two fixed wheels. Tool storage points on head and base. Supplied with 4m cable and 110V plug, deluxe tool kit, including stainless steel telescopic rigid extension tubes, cartridge filter and wet-use foam filter.

Motor Power:	1250W
Supply/Plug Type:	110V/Yellow - 16A-2P+E
Power Supply Cable Length:	4m
Maximum Vacuum Pressure:	125mbar
Airflow:	173m <sup>3</sup> /hr
Drum Size:	20L
Weight:	5kg
Vacuum Accessories Diameter:	Ø35mm
Filter Type:	Cartridge
Replacement Cartridge Filter:	PC200CFL
Replacement Foam Filters (Pack of 10):	PC200FF10
Optional Dust Bags (Pack of 5):	PC200PB5



**B-C SEE BELOW**  
**Wet & Dry Industrial Vacuum Cleaners 1400W with Stainless Drum & Auto Start**

Powerful 1400W motor head gives incredible suction through Ø35mm hosing. May also be used as a blower. Integral 3-pin socket provides power supply for dust-free tools up to 1400W. When operating in conjunction with a power tool, the cleaner automatically starts with the tool and stops ten seconds after the tool is switched off, to ensure tool and hose are left free of dust. Stainless steel drum on two castor and two fixed wheels, stainless steel telescopic rigid extension tube as well as tools for wet and dry operations. Tool storage points on head and base, supplied with cartridge filter and wet-use foam filter.

	<b>B</b>	<b>C</b>
Model No:	PC200SDAUTO	PC300SDAUTO
Motor Power:	1400W	1400W
Supply/Plug Type:	230V/3-Pin	230V/3-Pin
Power Supply Cable Length:	4m	4m
Maximum Vacuum Pressure:	165mbar	165mbar
Airflow:	120m <sup>3</sup> /hr	120m <sup>3</sup> /hr
Drum Size:	20L	30L
Weight:	8kg	9kg
Vacuum Accessories Diameter:	Ø35mm	Ø35mm
Filter Type:	Cartridge	Cartridge
Replacement Cartridge Filter:	PC200CFL	PC200CFL
Replacement Foam Filters (Pack of 10):	PC200FF10	PC200FF10
Optional Dust Bags (Pack of 5):	PC200PB5	PC300PB5



**D PC460**  
**60L Wet & Dry Vacuum Cleaner 1600W**  
**Stainless Drum**

Industrial stainless steel drum with tough composite base and head. Supplied with 3.5m EVA crush resistant hose, combo nozzle, crevice tool, 380mm squeegee, vac brush, accessory tool tidy, stainless steel rigid tubes, cartridge filter and foam filter. Tank has easy empty drain cap with screw-on hose. Fitted with two castor and two fixed wheels. Cable storage hooks mounted on frame, accessories and extension tube holders on base.

Motor Power:	1600W
Supply/Plug Type:	230V/3-Pin
Power Supply Cable Length:	4m
Drum Size:	60L
Weight:	16kg
Vacuum Accessories Diameter:	Ø38mm
Filter Type:	Cartridge
Replacement Cartridge Filter:	PC200CFL
Replacement Foam Filter:	PC460.ACC7



**E DFS/AK10**  
**Vacuum/Dust-Free Tool Adaptor**

Inner Diameter:	Ø35mm
Outer Diameters:	Ø35, 32, 27mm



**F VACHOSE5M**  
**5m Vacuum Hose**

5m Vacuum hose extension.

Inlet/Outlet Diameter:	Ø56/35mm
Applications:	PC195SD, PC200, PC200SD, PC200SDAUTO, PC200SD110V, PC300, PC300SD, PC300SDAUTO



## A PC477

### 77L Wet & Dry Industrial Vacuum Cleaner 2400W Stainless Steel Drum with Swivel Emptying

High powered, lightweight industrial unit. Stainless steel drum with dual filtration system for superior performance. Features safety shut-off for wet operation. Trolley with swivel drum and two rear locking wheels for easy emptying plus front swivel castors for added manoeuvrability. Supplied with Ø38mm accessory kit, 5m cable with 3-pin plug, cloth and cartridge filters. Fitted with twin motors offering superior vacuuming power. Particularly suitable for industrial and commercial applications where extra capacity and power are required. Optional front mounting squeegee available.

Motor Power:	2 x 1200W
Supply/Plug Type:	230V/3-Pin
Power Supply Cable Length:	5m
Airflow:	174m <sup>3</sup> /hr
Drum Size:	77L
Weight:	39kg
Vacuum Accessories Diameter:	Ø38mm
Filter Type:	Cartridge, Cloth
Replacement Cartridge Filter:	PC477.PF
Replacement Cloth Filter Assembly:	PC477.CF
Optional Squeegee:	PC477AK1

**A**

77L

2400W

230V

STAINLESS  
STEEL



Features swivel drum for easy emptying.



Optional Front Mounting Squeegee, order Model No. PC477AK1.

## B PC300BL

### 30L Bagless Wet & Dry Industrial Vacuum Cleaner 1200W Stainless Steel Drum

High powered industrial unit features cyclonic technology. Bagless design prevents loss of suction improving efficiency. Outlet produces clean air suitable for use as a blower. Features safety shut-off for wet operation. Includes a strong, comfortable handle, hose brackets, accessory storage base, durable stainless steel tank, liquid drainage device and an 'auto power take off' socket.

Motor Power:	1200W
Supply/Plug Type:	230V/3-Pin
Power Supply Cable Length:	4m
Maximum Vacuum Pressure:	180mbar
Drum Size:	30L
Weight:	11kg
Vacuum Accessories Diameter:	Ø35mm
Replacement Foam Filters (Pack of 10):	PC300BLFF10
Replacement Panel Filter (Single):	<b>C</b> PC300BLPF

**B**



30L

1200W

230V

STAINLESS  
STEEL



**C**



## C PC300BLPF

### Panel Filter for PC300BL



### Performance of Bagless Against Regular Models

Bagless models do not suffer from loss of suction as the tank fills with debris. Tests prove they retain their suction power and can be up to 50% more efficient than regular filter/cartridge models.

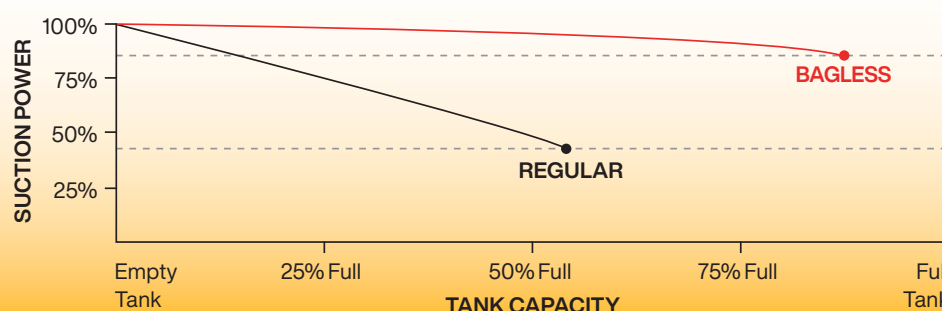

**A-B SEE BELOW**

**38L Dust-Free Wet & Dry Industrial Vacuum Cleaners Stainless Steel Drum M Class Filtration**

M Class wet and dry vacuum cleaners with a 38L stainless steel drum. Removes 99.9% of hazardous dust with the exposure limit value of >0.1mg/m<sup>3</sup>. When the air velocity starts to fall below 20 metres per second, a visual LED warning light on the top of the units will show. Built-in push clean system that forces air back through the filter restoring the suction power. These vacuum cleaners use a combination of filters and lining bags to create a 2-stage collection to stop any hazardous dust being left in the tank or becoming airborne. There is also the option of using a foam filter for wet cleaning which is reusable (all consumables are included; Tank liners (x5), dust bags (x5) and a foam filter). The accessories included are an antistatic crevice tool, antistatic round brush, multi-surface floor nozzle 12" and power tool adaptor.

	<b>A</b>	<b>B</b>
<b>Model No:</b>	PC380M	PC380M110V
<b>Drum Size:</b>	38L	38L
<b>Drum Type:</b>	Stainless Steel	Stainless Steel
<b>Maximum Vacuum Pressure:</b>	25Kpa	22Kpa
<b>Motor Power:</b>	1500W	1100W
<b>Supply/Plug Type:</b>	230V/3-Pin	110V/Yellow - 16A-2P+E
<b>Power Supply Cable Length:</b>	10m	10m

**A**

1500W

38L

13A 230V



**Wet & Dry**

STAINLESS STEEL



**What is M Class?**

The HSE recommend that you use a minimum of a M Class extraction unit if you are working with fine dusts in a construction or woodworking environment.

M Class filters catch 99.9% of wood dust and other dusts with OEL (Occupational Exposure Limit) values of >0.1mg/m<sup>3</sup> with a maximum permeability of 0.1%. For more information, and advice for using the correct filtration, please visit the HSE government website.

**B**

1100W 38L

16A 110V





**C PC380MFF**  
**Foam Filter - Pack of 3**  
 Suitable for Model No's PC380M and PC380M110V Industrial Vacuum Cleaners.

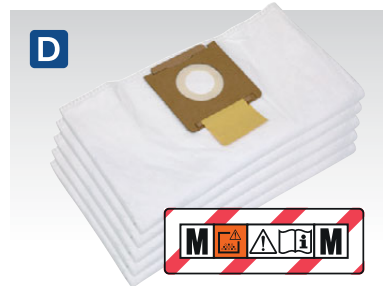

**D PC380MDB**  
**M Class Dust Bag - Pack of 5**  
 Suitable for Model No's PC380M and PC380M110V Industrial Vacuum Cleaners. 38L Capacity.



**E PC380MTL**  
**M Class Tank Liner - Pack of 5**  
 Suitable for Model No's PC380M and PC380M110V Industrial Vacuum Cleaners. 38L Capacity.



**F PC380MCF**  
**M Class Cartridge Filter**  
 M Class cartridge filter suitable for Model No's PC380M and PC380M110V Industrial Vacuum Cleaners.

**G-H SEE RIGHT**

**20V 20L Rechargeable Wet & Dry Vacuum Cleaner**

Lightweight portable cordless wet and dry vacuum cleaner. Convenient for use in the home, workshop or car, especially where mains power is not easily accessible. Features a 20L stainless steel drum mounted on four swivel castors for easy manoeuvrability. Unit also has built-in blower function which can be used for many applications in the home, workshop or garden. Body only. Supplied with accessory pack. Requires compatible 20V battery and mains charger, sold separately. See pages 844 to 872 for the rest of the SV20 range.

<b>Motor Power:</b>	140W
<b>Supply:</b>	20V
<b>Maximum Vacuum Pressure:</b>	80mbar
<b>Airflow:</b>	65m <sup>3</sup> /hr
<b>Drum Size:</b>	20L
<b>Weight:</b>	3.7kg
<b>Vacuum Accessories Diameter:</b>	Ø32mm
<b>Replacement Bag Filters (Pack of 5):</b>	PC20SD20VCF
<b>Replacement Foam Filters (Pack of 10):</b>	PC20SD20VFF10

**G**

Rechargeable

20L

20V



**H**

+ BATTERY (4Ah)

+ BATTERY CHARGER



Accessory Pack.

Model No:	Type:	Contents:
<b>G</b> PC20SD20V	Body Only	Vacuum Cleaner
<b>H</b> PC20VCOMBO4	Kit	PC20SD20V - Vacuum Cleaner CP20VBP4 - 4Ah Battery CP20VMC - Battery Charger



**A**  
230V



**B**  
35L  
230V + Air  
Dust-Free



**What is M Class?**

The HSE recommend that you use a minimum of a M Class extraction unit if you are working with fine dusts in a construction or woodworking environment.

M Class filters catch 99.9% of wood dust and other dusts with OEL (Occupational Exposure Limit) values of >0.1mg/m<sup>3</sup> with a maximum permeability of 0.1%. For more information, and advice for using the correct filtration, please visit the HSE government website.

**A-B SEE BELOW**

**35L Wet & Dry M Class Filtration Industrial Vacuum Cleaners**

High powered units designed for use with power tools. Model No. DFS35M is also suitable for use with air power tools. Certified for M Class dust extraction in accordance with EU directives, which protects the operator from dust particles hazardous to health. Supplied with Ø36mm flexible hose, crevice tool, multi-diameter tool adaptor, power tool cord clamps, M Class bag filter, M Class cartridge filter and foam filter. PC35230V is also supplied with inserts for liquid collection and hard floors. Can be set to continuous suction or in synchronisation with a power tool via an electronically controlled outlet or pneumatic tool via the air outlet (DFS35M only). Fitted with a self-cleaning filter technology designed to prevent filter blockages whilst in use. Fitted with four castors for manoeuvrability. A wet and dry floor cleaning kit is available for Model No. DFS35M, order Model No. DFS35MKIT (see **E** below).

	<b>A</b>	<b>B</b>
Model No:	PC35230V	DFS35M
Motor Power:	1200W	1000W
Supply/Plug Type:	230V/3-Pin	230V/3-Pin
Power Supply Cable Length:	6m	6m
Power Tool Capacity:	2000W	2000W
Maximum Vacuum Pressure:	240mbar	220mbar
Airflow:	216m <sup>3</sup> /hr	180m <sup>3</sup> /hr
Drum Size:	35L	35L
Drum Type:	Plastic	Plastic
Weight:	10.5kg	11.5kg
Vacuum Accessories Diameter:	Ø36mm	Ø10-35mm



**C DFS35CF**  
M Class Cartridge Filter

Applications: DFS35M, PC35230V, PC35110V



**D DFS35FF**  
Foam Filter

Applications: DFS35M, PC35230V, PC35110V



**E DFS35MKIT**  
Wet & Dry Floor Cleaning Accessories for DFS35M

Contents: 1.8m Ergonomic Hose, Aluminium 2pc Extension Tubes, Floor Brush Head, Liquid Insert, Hard Floor Insert



**F DFS35PB**  
M Class Dust Bag - Pack of 5

Applications: DFS35M, PC35230V, PC35110V



**A PC310**  
**20L Wet & Dry Valeting Machine with Accessories 1250W**

Cleans carpets, car interiors, fabrics and upholstery. Constructed from high-impact plastic which is dent resistant and rustproof. Supplied with carpet lance, handheld lance, full wet and dry vacuum accessory kit, including stainless steel telescopic rigid extension tube, cartridge filter and foam filter. Powerful pump forces cleaning fluid into fabric/carpet and 1250W suction power leaves surface virtually dry after one pass. Features safety shut-off for wet operation. Large capacity drum with external detergent tank for easy filling. Fitted with two fixed wheels and two castors. Cable storage hook, accessories and extension tube holders on head, plus additional accessory storage slots on base.

Motor Power:	1250W
Supply/Plug Type:	230V/3-Pin
Power Supply Cable Length:	5m
Drum Size:	20L
Drum Type:	Plastic
Weight:	8.2kg
Filter Type:	PET Type Cartridge
Replacement Cartridge Filter:	PC310CF
Optional Dust Bags (Pack of 5):	PC200PB5

**A** 1250W  
**20L**



**B SEE BELOW**  
**Carpet/Upholstery Detergent**

We recommend only Sealey cleaning products be used with valeting equipment. These chemical agents are specially formulated for use in Sealey valeting systems and provide powerful, non-corrosive cleaning power.

Model No:	Pack Qty:	Description:
VMR921S	1 x 1L	Upholstery Detergent
VMR921	10 x 1L	Upholstery Detergent
VMR925S	1 x 5L	Upholstery Detergent
VMR925	4 x 5L	Upholstery Detergent



PC310 Supplied with full accessory kit.

**B**



**C**

**30L**  
**1300W**  
**Remote Function**



**D**

**STAINLESS STEEL**

**30L**  
**1500W**

**Remote Function**



VMA914 & VMA915  
 Supplied with full accessory kit.



Switch controls on nozzle allow remote operation of detergent pump and vacuum motor.



**C-D SEE RIGHT**  
**30L Wet & Dry Valeting Machines**

High powered units ideal for cleaning carpets, car interiors, fabrics and upholstery. Supplied with carpet lance, handheld lance, full wet and dry vacuum accessory kit including adjustable stainless steel rigid extension tube, cartridge filter and foam filter. Large capacity drum with external detergent tank for easy filling. Features remote operation controls on nozzle, enabling switching between vacuum and detergent modes uninterrupted. Fitted with two fixed wheels and two castors. Model No. VMA915 includes cable storage hooks and accessory storage slots.

	<b>C</b>	<b>D</b>
Model No:	VMA914	VMA915
Motor Power:	1300W	1500W
Supply/Plug Type:	230V/3-Pin	230V/3-Pin
Power Supply Cable Length:	10m	10m
Drum Size:	30L	30L
Drum Type:	Plastic	Stainless Steel
Weight:	10kg	13kg
Replacement Foam Filter:	PC200FF10	PC200FF10
Replacement Dust Collection Bag (Pack of 5):	PC300PB5	PC300PB5
Replacement Cartridge Filter:	PC310CF	PC310CF



## A-B SEE BELOW

### Floor Sweepers

Suitable for maintaining any hard floor and ideal for removing dirt, dust and debris from large surface areas. Features 4-brush system with two side brushes and two further brushes set underneath the unit to easily lift debris into the hopper. Fitted with tubular handle and adjustable castor wheel that raises the sweeper 20mm enabling larger pieces of debris to be swept up.

	A	B
Model No:	FSW70	FSW80
Operating Width:	700mm	800mm
Hopper Capacity:	20L	40L



**A** 20L  
700mm



**B** 40L  
800mm



**B**



**C** BM26  
Metal Dustpan & Brushes

Ideal for a wide variety of domestic and workshop jobs. Supplied with 11"(280mm) soft and hard bristle brushes. Heavy-duty, metal dustpan suitable for picking up dirt, dust and larger debris. Fitted with carry handle.



**D** BM04  
Composite Dustpan & Brush Set

Manufactured from quality composite material for strength and durability. Brush features long-life flexible bristles and locks onto pan for easy storage. Pan features rubber squeegee edge to ensure all dirt can be swept up with ease.



**E** NEW

**E** GS01  
Gutter Scoop

Lightweight and durable polypropylene scoop. Can be used for various tasks including sowing plant and grass seeds, as well as clearing gutters.

Blade Size:	65 x 260mm
Handle:	110mm
Length:	430mm



**F**  
8"

**F** BM27  
8"(200mm) Scrubbing Brush

Heavy-duty 8" scrubbing brush manufactured from hardwood. Contains stiff bassine fibres, great for rough surfaces. Suitable for indoor and outdoor use and ideal for use on patios, block paving, decking and laminate flooring.



**G** 11"  
**H** 11"

**G-H** SEE BELOW  
11"(280mm) Hand Brushes

Manufactured from hardwood with a clear lacquered finish. Features ergonomic handle and hanging hole for easy storage.

Model No:	Head Size:	Bristle Type:
<b>G</b> BM25H	11"(280mm)	Hard
<b>H</b> BM25S	11"(280mm)	Soft

Type/Fill:	Hard/Bassine
Head Size:	8"(200mm)



**I** BM04HX  
Bulldozer Yard Dustpan & Brush Set

Hard-wearing, dual purpose, split-tip polypropylene and PVC fibres ideal for indoor and outdoor surfaces. Stiff inner fibres sweep concrete, asphalt and other rough surfaces. Soft outer fibres are ideal for sweeping fine dirt and dust. Brush locks on to pan for easy storage. Large industrial pan with a rubber squeegee edge to ensure all media can be swept with ease.

Type/Fill:	Hard & Soft/PVC-Polypropylene
Head Size:	180 x 80mm



**A-I SEE BELOW**

**Brooms**

Comprehensive range of brooms available in hard and soft bristles. 12"(300mm) Models have handle support bracket and 24"(600mm) and 36"(900mm) models have metal handle strengthening support. Ideal for indoor or outdoor use. Model No. BM13H is suitable for heavy-duty use in yards and gardens.

Model No:	Type/Fill:	Head Size:
<b>A</b> BM11S	Soft/PVC	11"(280mm)
<b>B</b> BM12H	Hard/Bassine	12"(300mm)
<b>C</b> BM12S	Soft/Coco	12"(300mm)
<b>D</b> BM13H	Hard/PVC	13"(325mm)
<b>E</b> BM13HX	Hard/Cane	13"(325mm)
<b>F</b> BM24H	Hard/Bassine	24"(600mm)
<b>G</b> BM24S	Soft/Coco	24"(600mm)
<b>H</b> BM36H	Hard/Bassine	36"(900mm)
<b>I</b> BM36S	Soft/Coco	36"(900mm)



**K BM16SC 16"(405mm) Heavy-Duty Stiff/Hard Bristle Broom with Scraper**

16"(405mm) Heavy-duty, hard bristle broom fitted with handle support bracket. Ideal for indoor or outdoor use, particularly for heavy-duty use in yards and gardens. Also features scraper, ideal for ice and snow.

<b>Head Size:</b>	16"(405mm)
-------------------	------------



**J BM24HX 24"(600mm) Bulldozer Yard Broom**

Hard-wearing, dual purpose, split-tip polypropylene and PVC fibres ideal for indoor and outdoor surfaces. Stiff inner fibres sweep concrete, asphalt and other rough surfaces. Soft outer fibres are ideal for sweeping fine dirt and dust. Features high quality steel handle with grip bracket to secure and prevent damage to handle and resin block. Fitted with handle storage clips for easy storage.

<b>Type:</b>	Hard & Soft
<b>Fill:</b>	PVC-Polypropylene
<b>Head Size:</b>	24"(600mm)





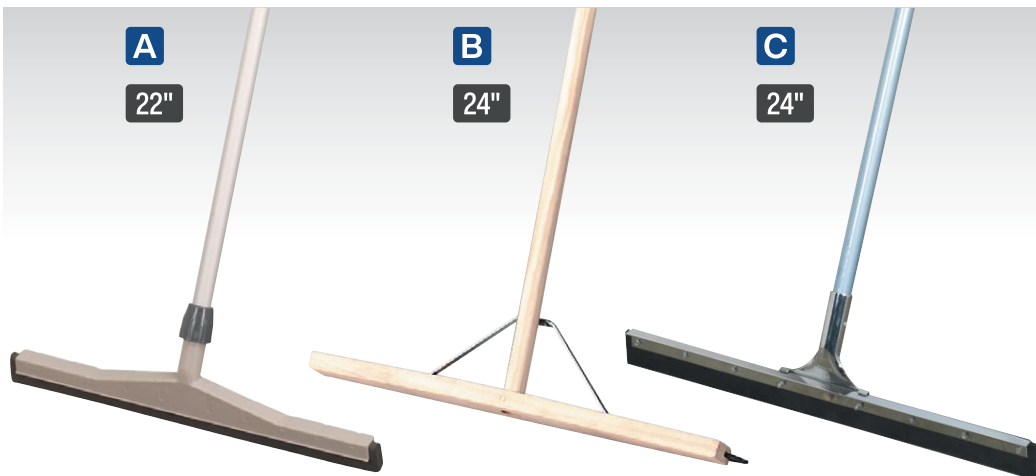

**A-C SEE BELOW**

**Floor Squeegees**

Range of three floor squeegees, ideal for oil, water and other liquid spills. Model No. BM22FSP is fitted with foam strip and Model No's BM24RS and BM24RSM are fitted with rubber strip.

Model No:	Type/Fill:	Handle:	Head Size:
<b>A</b> BM22FSP	Foam	Aluminium	22"(560mm)
<b>B</b> BM24RS	Rubber	Wood	24"(600mm)
<b>C</b> BM24RSM	Rubber	Aluminium	24"(600mm)



**D CC64 Large Sponge**

General-purpose bone-shaped sponge.



**E CC68 Forta Microfibre Cloth**

Developed by professional detailers for fast removal of dust and wax from the car surface. Ultra-fine fibres attract, lift and hold dirt, dust and grease with just a little water.

**Size:** 400 x 400mm



**F SSW80 Heavy-Duty Hand Wipes Textured Pack of 80**

Heavy-duty textured hand wipes. Ideal for removing dirt, oil, grease, grime and non-cured petroleum based contaminants. Antimicrobial properties leave hands hygienically clean. Contains 80 sheets.



**G WFS02 300mm Workshop Floor Scraper**

Heavy-duty floor scraper suitable for use in both domestic and industrial environments. Carbon steel blade ideal for removing grease, dirt and other remains from tiled, concrete and laminate flooring. Strong, lightweight fibreglass handle with comfortable grip.

<b>Blade Size:</b>	300mm
<b>Length:</b>	1500mm



**H CC52 Long Handle Dip & Wash Brush**

Fine, split-top bristles gently loosen and brush away dirt. Does not mark expensive clear coats or painted finishes. Long handle for access to hard-to-reach areas.



**I SCW3 Hand Wipes Bucket - Pack of 150**

Durable, extra-large wipes for removing a variety of tough substances including oil and grease. Moisture locked wipes means no need for water. Supplied in a dispensing bucket containing 150 wipes.

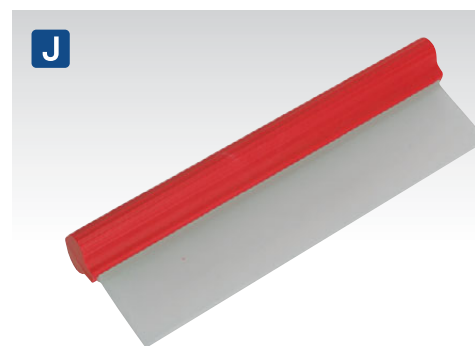

**J CC65 Aqua Flexi-Blade**

Cuts drying time in half by removing excess water.

<b>Blade Length:</b>	300mm
----------------------	-------





**A BM02**  
**225g Pure Yarn Cotton Mop**  
 Highly absorbent, 100% pure yarn cotton head. Features straight-grained wooden handle with galvanized steel socket.



**B BM05**  
**340g Pure Yarn Cotton Mop**  
 Highly absorbent, 100% pure yarn cotton head. Features straight-grained wooden handle with galvanized steel socket.



**C BM17**  
**350g Cotton Mop**  
 Lightweight highly absorbent cotton head, ideal for cleaning wooden, ceramic, stone and vinyl flooring. Features detachable mop head and 1330mm plastic handle. Replacement mop head available separately, order Model No. BM17R.



**D BM03**  
**450g Kentucky Mop**  
 Extra thick, highly absorbent, 100% cotton head. Features straight-grained wooden handle with metal locking clip.



**E BM14**  
**Aluminium Mop with Disposable Head**  
 Allows for effortless cleaning when dealing with oil or other viscous substances. Mop head is completely removed and replaced by twisting the threaded mop handle.

Head Weight:	200g
Replacement Head (Pack of 5):	DKM05



**F DKM05**  
**Disposable Kentucky Mop Head - Pack of 5**  
 Pack of five disposable Kentucky mop heads. Designed for single use before disposing. For use with Model No. BM14 Aluminium Mop.

Head Weight:	200g Each, 1kg per Pack
--------------	-------------------------

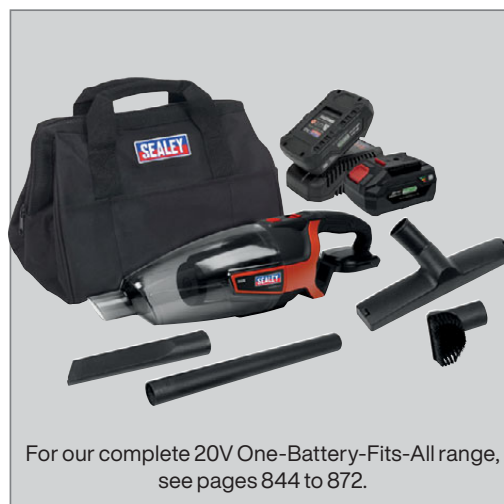

For our complete 20V One-Battery-Fits-All range, see pages 844 to 872.



**G WHT150**  
**150m White Embossed 2-Ply Paper Roll**  
 Pack of 6

Ply:	2
Type:	Embossed
Width:	175mm
Length:	150m
Pack Qty:	6



**H BLU150**  
**150m Blue Embossed 2-Ply Paper Roll**  
 Pack of 6

Ply:	2
Type:	Embossed
Width:	190mm
Length:	150m
Pack Qty:	6





STAINLESS STEEL

**A BM8L**  
**12L Stainless Steel Bucket**  
 Manufactured from heavy-duty stainless steel grade 202. Perfect for domestic and industrial applications.



**B BM08**  
**13L Galvanized Mop Bucket**  
 Manufactured from heavy-duty galvanized steel. Fitted with mop head wringer and carry handle. Ideal for domestic and industrial applications.



**C BM16**  
**14L Composite Bucket**  
 Manufactured from highly durable thick walled polypropylene with pouring spout. Fitted with plastic comfort grip handle.



**D SEE BELOW**  
**Premium Powder-Free Disposable Nitrile Gloves - Packs of 100**  
 Offers a high degree of protection against a variety of chemicals. More durable than standard latex gloves. Provides excellent protection whilst being light and flexible. Nitrile material, ideal for people with latex protein allergies. Manufactured to EN455 Parts 1, 2 & 3.

<b>Model No:</b>	<b>Size:</b>
SSP55L	Large
SSP55XL	X-Large



**E-F SEE BELOW**  
**Mop Buckets**  
 Heavy-duty composite construction with detachable side press wringer and mop holder. Features Ø50mm non-marking castor wheels for added manoeuvrability. Both units fitted with carry handle.

<b>Model No:</b>	<b>Capacity:</b>
<b>E BM09</b>	20L
<b>F BM01</b>	36L



**G BM07**  
**15L Mop Bucket - 2 Compartment**  
 Manufactured with two compartments featuring removable mop head wringer. Ideal for keeping clean water and dirty water separate while cleaning. Fitted with carry handles.



**H BM30**  
**Janitorial Trolley**  
 Robust unit fitted with two castors and two rubber wheels. Designed to accommodate mop buckets, brooms, brushes, cleaning agents and other necessary items. Fitted with hooks to hang refuse bags and lid to contain any odours.

**Dimensions (W x D x H):** 470 x 1170 x 995mm

**A NEW**

50L



**B NEW**

50L



**C NEW**

50L



**D NEW**

50L



**A-H SEE BELOW**  
**Refuse/Storage Bins**

Durable refuse/storage bins made from polypropylene. Fitted with lid latches to keep lid secure. 75L Models also feature carry handles. Suitable for outdoor use.

Model No:	Capacity:	Size:	Colour:
<b>A</b> BM50	50L	400 x 400 x 510mm	Black
<b>B</b> BM50B	50L	400 x 400 x 510mm	Blue
<b>C</b> BM50G	50L	400 x 400 x 510mm	Green
<b>D</b> BM50R	50L	400 x 400 x 510mm	Red

Model No:	Capacity:	Size:	Colour:
<b>E</b> BM75	75L	600 x 400 x 570mm	Black
<b>F</b> BM75B	75L	600 x 400 x 570mm	Blue
<b>G</b> BM75G	75L	600 x 400 x 570mm	Green
<b>H</b> BM75R	75L	600 x 400 x 570mm	Red

**E NEW**

75L



**F NEW**

75L



**G NEW**

75L



**H NEW**

75L



**PLATFORM TRUCKS**  
 For more information on our platform trucks, see page 1373.



Model No. CST991



Model No. CST992



**NEW** **A** 95L



**B** 95L



**C** 95L



**D** 95L



**A-D SEE ABOVE**

**95L Refuse/Storage/Wheelie Bins**

Durable refuse/storage bins made from polypropylene. Fitted with carry handles and lid latches to keep lid secure. Suitable for outdoor use.

Model No:	Colour:
<b>A</b> BM95	Black
<b>B</b> BM95B	Blue
<b>C</b> BM95G	Green
<b>D</b> BM95R	Red
<b>Capacity:</b>	95L
<b>Dimensions (W x D x H):</b>	600 x 400 x 740mm

**E** 100L



**F** 100L



**G** 100L



**H** 100L



**E-H SEE BELOW**

**100L Refuse/Storage/Wheelie Bins**

Durable refuse/wheelie bins made from polypropylene. Bins are available in four different colours allowing you to set up your own colour-coding system. Alternatively, common colour-coding could be used such as black for general waste, green for glass, blue for paper and red for plastics. Solid rear axle with two Ø200mm wheels and three robust handles allow the bins to be moved easily even when full.

Model No:	Colour:
<b>E</b> BM100	Black
<b>F</b> BM100B	Blue
<b>G</b> BM100G	Green
<b>H</b> BM100R	Red
<b>Capacity:</b>	100L
<b>Dimensions (W x D x H):</b>	595 x 570 x 765mm



**BULLDOZER YARD  
DUSTPAN & BRUSH SET**  
For information on our Bulldozer  
Yard Dustpan & Brush Set, Model  
No. BM04HX, see page 1324.

**A**



**A-D SEE BELOW**

**100L Refuse/Wheelie Bins with Foot Pedal**

Durable refuse/wheelie bins made from polypropylene with quick release foot pedal. Bins are available in four different colours allowing you to set up your own colour-coding system. Alternatively, common colour-coding could be used such as black for general waste, green for glass, blue for paper and red for plastics. Solid rear axle with two Ø200mm wheels and three robust handles allow the bins to be moved easily even when full.

Model No:	Colour:
<b>A</b> BM100P	Black
<b>B</b> BM100PB	Blue
<b>C</b> BM100PG	Green
<b>D</b> BM100PR	Red
<b>Capacity:</b>	100L
<b>Dimensions (W x D x H):</b>	595 x 570 x 765mm

**B**

**C**

**D**

**100L**



**A-D**



**E**

**45L**



**E** BM60

**45L Plastic Pedal Bin**

Manufactured from heavy-duty polypropylene. Square design allows unit to sit flush against almost any wall, ideal for where space is limited. Fitted with plastic foot pedal for hands-free operation and carry handle.

**Size (W x D x H):** 400 x 390 x 600mm

**F**



**WORKSAFE®**

**F SEE BELOW**

**Hi-Vis Yellow Jackets with Quilted Lining, Elasticated Waist & Cuffs**

Waterproof motorway jackets with full quilted lining for greater warmth and comfort. Fitted with retractable hood, two outer pockets, inner phone pocket and snap closing for added protection against rain. Conforms to EN ISO 20471:2013+A1:2016 Class 3 and EN 343:2003+A1:2007 Class 3:1.

Model No:	Size:
<b>802L</b>	Large
<b>802XL</b>	X-Large
<b>802XXL</b>	XX-Large

**G**



**G SEE BELOW**

**Rigger's Gloves - Pair**

Strong stitching, a generous fit and quality materials make this an ideal glove for general-purpose trade use. Conforms to BS EN 21430:2020 & 388:2016 Level 2242X.

Model No:	Pack Quantity:
<b>SSP12</b>	1
<b>SSP12/6</b>	6





**A RCB01**  
**Wall-Mounting Cigarette Bin**  
 2-Piece design for easy installation, emptying and cleaning. Metal construction with Zintec® liner. Fitted with high quality lock and supplied with two keys. Includes fittings for wall-mounting. Suitable for use in building entrances and smoking areas.

**Size (W x D x H):** 260 x 80 x 320mm



**B RCB02**  
**Stainless Steel Wall-Mounting Cigarette Bin**  
 2-Piece design for easy installation, emptying and cleaning. Stainless steel construction with Zintec® liner. Fitted with high quality lock and supplied with two keys. Includes fittings for wall-mounting. Suitable for use in building entrances and smoking areas.

**Size (W x D x H):** 260 x 80 x 320mm



**C RCB04**  
**Cigarette Floor Ashtray**  
 Manufactured from 1mm mild steel and finished for resistance to corrosion. Twin openings in concave cover for safe and hygienic use. Suitable for use in building entrances and smoking areas.

**Size (W x D x H):** 335 x 230 x 112mm



**D RCB07**  
**Cigarette Bin**  
 Metal construction cigarette bin with black powder coated body. Easy installation, emptying and cleaning. Fitted with high quality lock and supplied with two keys. Suitable for use in building entrances and smoking areas.

**Size (W x D x H):** 240 x 240 x 880mm



**E RCB06**  
**8L Cigarette Ashtray & Litter Bin**  
 Metal construction with black powder coated body with side-opening and aluminium lid featuring built-in ashtray. Supplied with removable metal inner liner and carry handle making emptying quick and easy. Ideal for use in building entrances and smoking areas.

**Size (W x D x H):** 270 x 270 x 590mm



**F-J SEE BELOW**

**Brooms**

Comprehensive range of brooms available in hard and soft bristles. 12"(300mm) Models have handle support bracket whilst 24"(600mm) and 36"(900mm) models have metal handle strengthening support. Ideal for indoor or outdoor use. Model No. BM13H is suitable for heavy-duty use in yards and gardens.

Model No:	Type/Fill:	Head Size:
<b>F</b> BM11S	Soft/PVC	11"(280mm)
<b>G</b> BM12H	Hard/Bassine	12"(300mm)
<b>H</b> BM12S	Soft/Coco	12"(300mm)
<b>I</b> BM13H	Hard/PVC	13"(325mm)
<b>J</b> BM13HX	Hard/Cane	13"(325mm)

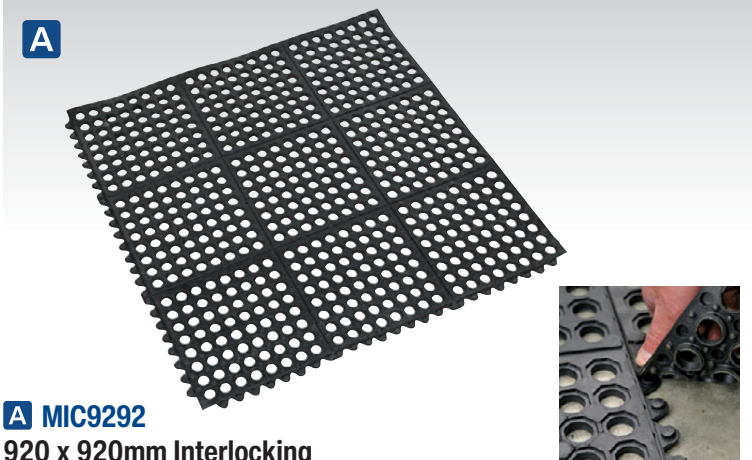

**A MIC9292**  
**920 x 920mm Interlocking Anti-Fatigue Matting**

Hard-wearing rubber anti-slip mat provides fatigue relief and insulation from cold concrete floors. Features four interlocking edges to provide desired area coverage.

<b>Size:</b>	920 x 920mm
<b>Thickness:</b>	12mm

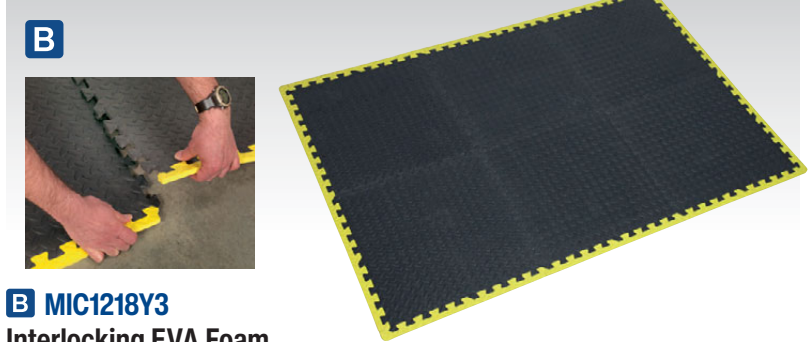

**B MIC1218Y3**  
**Interlocking EVA Foam Workshop Mat Set with Hi-Vis Edges**

Hard-wearing EVA foam anti-slip matting suitable for use in the workshop and machine room. Provides fatigue relief and insulation from cold concrete floors. All tiles can be interlocked to make one bordered area, alternatively can be laid out as three separate bordered areas of two tiles each. The hi-vis border increases visibility, improving safety.

<b>Contents:</b>	Tiles (x6), Hi-Vis Edges (x18)
<b>Overall Dimensions (6 tile):</b>	1240 x 1825mm
<b>Overall Dimensions (2 tile):</b>	650 x 1240mm
<b>Thickness:</b>	10mm



**C MCR0919**  
**910 x 1980mm Anti-Fatigue Workshop Matting**

Hard-wearing lightweight cushioned anti-fatigue matting. Provides insulation from cold concrete floors. Slip resistant patterned surface. Suitable for use in workshops, garages, kitchens, bars and gyms.

<b>Size:</b>	910 x 1980mm
<b>Thickness:</b>	8mm



**D MIC1218**  
**1200 x 1800mm Interlocking EVA Foam Workshop Mat Set**

Hard-wearing anti-slip EVA foam matting suitable for use in the workshop and machine room. Provides fatigue relief and insulation from cold concrete floors. Interlocks to make any length in units of 600mm. End section edges to prevent damage.

<b>Contents:</b>	600 x 600mm Tiles (x6), Edges (x18)
<b>Thickness:</b>	11mm



**E DRM01**  
**450 x 750mm Rubber Disinfection Mat With Removable Polyester Carpet**

Rubber mat with slip resistant base. Removable polyester carpet fits in the mat's ingress, can be easily cleaned or replaced. Mat capacity holds up to 1L of disinfectant. Suitable for indoor and outdoor use. Can be used before entrances of kitchens, farms, labs of agro-food manufacturing, poultry houses, hospitals, airports, schools, offices and any other areas requiring foot disinfection.

<b>Size (W x L x D):</b>	450 x 750 x 18mm
<b>Disinfectant Capacity:</b>	1L



**F-G SEE BELOW**  
**Ribbed Workshop Matting**

Hard-wearing natural rubber with a slip resistant fluted surface. Provides insulation from cold concrete floors. Can be used on workbenches to help prevent damage to fragile parts and worktop.

Model No:	Size:	Thickness:
<b>F MCR1025</b>	1000 x 2500mm	3mm
<b>G MCR10100</b>	1000 x 10000mm	3mm



**H MRM0915**  
**1500 x 900mm Anti-Fatigue Workshop Matting**

Hard-wearing rubber provides fatigue relief and insulation from cold concrete floors. Raised circular surface design for superior slip resistance. Moulded bevelled edge to reduce risk of tripping.

<b>Size (L x W):</b>	1500 x 900mm
<b>Thickness:</b>	14mm

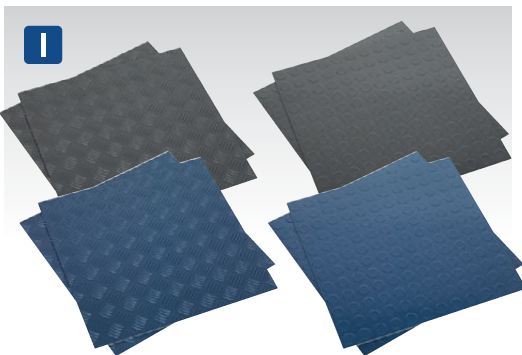

**I SEE BELOW**  
**Vinyl Floor Tiles with Peel & Stick Backing Packs of 16**

For full specification see page 1050.

Model No:	Type:
<b>FT1B</b>	Blue Treadplate Finish
<b>FT1S</b>	Silver Treadplate Finish
<b>FT2B</b>	Blue Coin Finish
<b>FT2S</b>	Silver Coin Finish



## A-E SEE BELOW

### Submersible Water Pumps

Manufactured from corrosion resistant materials with stainless steel motor case and Noryl® base cover. Available with or without automatic cut-out. Minimum water depth of just 20mm. Designed for clean water although these pumps will accept small particles up to 5mm. Suitable for the effective drainage of cellars, sinks, cisterns, baths and the general transfer of water.

#### LOW VOLTAGE SUBMERSIBLE TRANSFER PUMPS

For full details, see page 668.



	<b>A</b>	<b>B</b>	<b>C</b>	<b>D</b>	<b>E</b>
<b>Model No:</b>	WPC100	WPC100A	WPC150A	WPC235A	WPC250A
<b>Cut-Out:</b>	Manual	Automatic	Automatic	Automatic	Automatic
<b>Outlet OD:</b>	Ø32mm	Ø32mm	Ø32mm	Ø38mm	Ø38mm
<b>Maximum Output/Min:</b>	100L(22gal)	100L(22gal)	167L(36gal)	208L(45gal)	250L(55gal)
<b>Maximum Head:</b>	6m	6m	8m	8.5m	9.5m
<b>Maximum Water Depth:</b>	5m	5m	7m	7m	5m
<b>Minimum Water Depth:</b>	20mm	20mm	20mm	20mm	20mm
<b>Maximum Particle Size:</b>	5mm	5mm	5mm	5mm	5mm
<b>Motor Power:</b>	250W	250W	500W	750W	900W
<b>Supply/Plug Type:</b>	230V/3-Pin	230V/3-Pin	230V/3-Pin	230V/3-Pin	230V/3-Pin
<b>Power Supply Cable Length:</b>	10m	10m	10m	10m	10m



For Dirty Water

Auto Cut-Out

230V



STAINLESS STEEL

For Dirty Water

Auto Cut-Out

230V



STAINLESS STEEL

Auto Cut-Out

230V

### **H** WPS225A 225L/min Automatic Stainless Submersible Dirty Water Pump

Manufactured from corrosion resistant materials with stainless steel body and motor case. Fitted with automatic cut-out. Minimum water depth of 30mm. Designed for operation in dense and dirty water. Suitable for the effective drainage of cellars, sinks, cisterns, baths and the general transfer of water and dense liquids.

### **I** WPS250A 250L/min Automatic Stainless Submersible Clean Water Pump

Manufactured from corrosion resistant materials with stainless steel body and motor case. Fitted with automatic cut-out. Minimum water depth of 30mm. Designed for clean water although these pumps will accept small particles up to 5mm. Suitable for the effective drainage of cellars, sinks, cisterns, baths and the general transfer of water.

## F-G SEE TABLE

### Automatic Submersible Dirty Water Pumps

Manufactured from corrosion resistant materials with stainless steel motor case and Noryl® base cover. Fitted with automatic cut-out. Minimum water depth of 40mm. Designed for operation in dense and dirty water. Suitable for the effective drainage of cellars, sinks, cisterns, baths and the general transfer of water and dense liquids.

	<b>F</b>	<b>G</b>	<b>H</b>	<b>I</b>
<b>Model No:</b>	WPD133A	WPD235A	WPS225A	WPS250A
<b>Cut-Out:</b>	Automatic	Automatic	Automatic	Automatic
<b>Outlet OD:</b>	Ø32mm	Ø38mm	Ø38mm	Ø38mm
<b>Maximum Output/Min:</b>	133L(30gal)	217L(47gal)	225L(49gal)	250L(54gal)
<b>Maximum Head:</b>	5m	8m	7.5m	8m
<b>Maximum Water Depth:</b>	7m	7m	5m	7m
<b>Minimum Water Depth:</b>	40mm	40mm	30mm	30mm
<b>Maximum Particle Size:</b>	30mm	35mm	15mm	5mm
<b>Motor Power:</b>	400W	750W	750W	600W
<b>Supply/Plug Type:</b>	230V/3-Pin	230V/3-Pin	230V/3-Pin	230V/3-Pin
<b>Power Supply Cable Length:</b>	10m	10m	10m	10m



**KEEP SAFE!**

Always use RCD devices. See page 1181 for details.





**A** 7020L/hr  
Auto Cut-Out  
Low Level  
230V

**Minimum Water Depth 2mm**

**A WPL117A**  
**117L/min Automatic Low Level 2mm Submersible Water Pump**

Manufactured from corrosion resistant materials with stainless steel motor case and Noryl® base cover. Fitted with automatic cut-out. Puddle pump with minimum water depth of just 2mm makes this ideal for flood recovery. Designed for clean water although these pumps will accept small particles up to 5mm. Suitable for the effective drainage of cellars, sinks, cisterns, baths and the general transfer of water.

<b>Cut-Out:</b>	Automatic
<b>Outlet:</b>	Ø32mm
<b>Maximum Output/Min:</b>	117L(26gal)/min
<b>Maximum Head:</b>	8m
<b>Minimum Water Depth:</b>	2mm
<b>Maximum Water Depth:</b>	7m
<b>Maximum Particle Size:</b>	5mm
<b>Motor Power:</b>	400W
<b>Supply/Plug Type:</b>	230V/3-Pin
<b>Power Supply Cable Length:</b>	10m

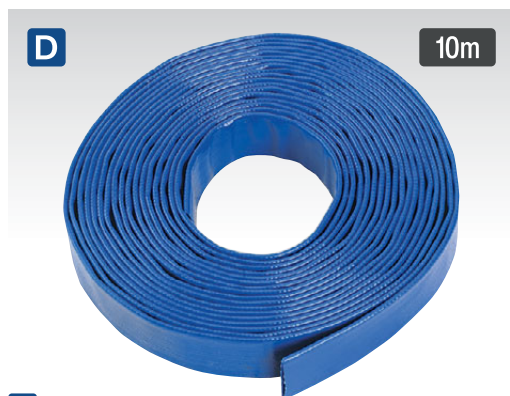

**D** 10m

**D SEE BELOW**  
**10m Layflat Water Hoses**

High quality PVC hose reinforced with synthetic fibres. Suitable for water discharge only.

Model No:	Length:	Hose Diameter:
LFH1025	10m	Ø25mm
LFH1032	10m	Ø32mm
LFH1038	10m	Ø38mm
LFH1050	10m	Ø50mm



**B** 3000L/hr  
Auto Cut-Out  
230V

**B WPB50A**  
**50L/min Submersible Water Butt Pump**

Manufactured from corrosion resistant materials with a stainless steel motor case and Noryl® base cover. Ideal for pumping water straight from a water butt directly onto your garden. Supplied with a 2-piece aluminium swan neck extension pipe, adjustable flow control feature and snap on connector.

<b>Cut-Out:</b>	Automatic
<b>Outlet:</b>	19mm
<b>Maximum Output/Min:</b>	50L(13gal)/min
<b>Maximum Head:</b>	10m
<b>Minimum Water Depth:</b>	50mm
<b>Maximum Water Depth:</b>	5m
<b>Maximum Particle Size:</b>	0.5mm
<b>Motor Power:</b>	350W
<b>Supply/Plug Type:</b>	230V/3-Pin
<b>Power Supply Cable Length:</b>	14m



**E** 5520L/hr  
Auto Cut-Out  
40m Head  
230V  
STAINLESS STEEL



**C** 5580L/hr  
55m Head  
230V  
9 STAGE PUMP  
HIGH FLOW  
STAINLESS STEEL

**C WPW935**  
**9-Stage 55m Head Borehole/Deep Well Pump**

Manufactured from high-impact stainless steel for added durability and corrosion resistance. Ideal for installing in traditional wells, clean water deposits, boreholes and garden irrigation systems. 9-Stage pump enables high flow rates, high heads and ensures a stable performance.

<b>Cut-Out:</b>	Manual
<b>Outlet:</b>	Ø38mm
<b>Maximum Output/Min:</b>	93L(20gal)/min
<b>Maximum Head:</b>	55m
<b>Number of Stages:</b>	9
<b>Motor Power:</b>	1000W
<b>Supply/Plug Type:</b>	230V/3-Pin
<b>Power Supply Cable Length:</b>	22m



**E WPS92A**  
**92L/min 40m Head Automatic Submersible Stainless Water Pump**

Manufactured from corrosion resistant materials with stainless steel body and motor case. Maximum head of 40m makes this unit ideal for wells. Fitted with automatic cut-out. Minimum water depth of 32mm. Designed for clean water although these pumps will accept small particles up to 0.5mm. Suitable for the effective drainage of cellars, sinks, cisterns, baths and the general transfer of water.

<b>Cut-Out:</b>	Automatic
<b>Outlet:</b>	Ø32mm
<b>Maximum Output/Min:</b>	92L(20gal)/min
<b>Maximum Head:</b>	40m
<b>Minimum Water Depth:</b>	32mm
<b>Maximum Water Depth:</b>	7m
<b>Maximum Particle Size:</b>	0.5mm
<b>Motor Power:</b>	1000W
<b>Supply/Plug Type:</b>	230V/3-Pin
<b>Power Supply Cable Length:</b>	10m







600L/min



**A EWP050**  
Ø50mm Water Pump 7hp Petrol

Economically designed petrol powered water pump with recoil starting. Suitable for on site applications where mains power supply is not available. Featuring Ø50mm inlet/outlet with 28m pumping head, offering a high flow rate up to 600L/min of water. Fitted onto frame with high-density rubber shock absorbers, frame also aids with protection from accidental damage.

Motor Power:	7hp
Motor Type:	4-Stroke/Unleaded
Inlet Diameter:	Ø50mm
Outlet Diameter:	Ø50mm
Maximum Output/Min:	600L
Maximum Head:	28m
Maximum Suction Head:	8m
Maximum Tank Capacity:	3.6L
Noise Rating LwA:	99dB(A)
Dry Weight:	27kg
Dimensions:	477 x 385 x 420mm



**B**  
3000L/hr  
230V



**C**  
3300L/hr  
230V

**B-C SEE RIGHT**  
Surface Mounting Water Pumps

Manufactured from high impact thermoplastic material or stainless steel for added durability. Suction pump suitable for drawing brackish water up to 8m. Model No. WPS062S includes a removable filter for easier maintenance.

Model No:	WPS060	WPS062S
Cut-Out:	Manual	Manual
Outlet:	1" BSP	1" BSP
Maximum Output/Min:	50L(11gal)	55L(12gal)
Maximum Head:	35m	38m
Maximum Suction Height:	8m	8m
Maximum Particle Size:	1mm	1mm
Motor Power:	650W	800W
Supply/Plug Type:	230V/3-Pin	230V/3-Pin
Power Supply Cable Length:	1m	1m



**D**  
3000L/hr  
Auto Cut-Out  
230V



**E**  
3300L/hr  
Auto Cut-Out  
230V  
STAINLESS STEEL

**D-E SEE RIGHT**  
Surface Mounting Booster Pumps

Manufactured from high impact thermoplastic material or stainless steel for added durability. Ideal for boosting or maintaining water pressure within the home or garden water supplies. Fitted with automatic pressure cut-off valve. Suitable for lifting water up to 8m.

Model No:	WPB050	WPB062S
Cut-Out:	Automatic	Automatic
Outlet:	1" BSP	1" BSP
Maximum Output/Min:	50L(11gal)	55L(12gal)
Maximum Head:	35m	38m
Maximum Suction Height:	8m	8m
Maximum Particle Size:	1mm	1mm
Motor Power:	600W	800W
Supply/Plug Type:	230V/3-Pin	230V/3-Pin
Power Supply Cable Length:	1m	1m



**F EWP050SW**  
Ø50mm x 5m Solid Wall Suction Hose for EWP050

Solid wall hose for use on suction side of water pumps. For use with Model No. EWP050.

Length:	5m
Size ID/OD:	Ø50/60mm



**G SEE BELOW**  
Solid Wall Suction Hoses

Solid wall hose for use on suction side of water pumps. Suitable for use with Model No. WPS060 Surface Mounting Water Pump.

Model No:	Length:	Size (ID/OD):
WPS060HS	4m	Ø25/30mm
WPS060HL	7m	Ø25/30mm



**H**  
1L



**I**  
2L

**H-I SEE BELOW**  
Inlet Filters for Surface Mounting Pumps

High quality filters with a composite case. Includes a screw top lid to reveal the easy clean filter element. Ideal for fitting to Sealey and other brands of surface mounting pumps. Includes two female to male adaptors.

Model No:	Capacity:	Applications:
WPF1	1L	WPB050, WPS060
WPF2	2L	WPB050, WPS060, WPS062S, WPB062S



**A-C SEE BELOW**

**Stainless Steel Submersible Pond Pump**

Manufactured from stainless steel for added durability and corrosion resistance. Suitable for creating garden water features. They also provide the important functions of filtration and water circulation which are necessary to maintain healthy plant and fish life.



	<b>A</b>	<b>B</b>	<b>C</b>
<b>Model No:</b>	WPP1750S	WPP3000S	WPP3600S
<b>Fountain Head Effects:</b>	A(x2), B, C	A, B, C	A, B, C
<b>Outlet Size OD:</b>	Ø13mm	Ø13mm	Ø13mm
<b>Maximum Output:</b>	1750L(360gal)/hr	3000L(600gal)/hr	3600L(780gal)/hr
<b>Maximum Head:</b>	2.3m	3.2m	4m
<b>Motor Power:</b>	50W	85W	120W
<b>Supply/Plug Type:</b>	230V/3-Pin	230V/3-Pin	230V/3-Pin
<b>Power Supply Cable Length:</b>	10m	10m	10m

**Fountain Head Effects**

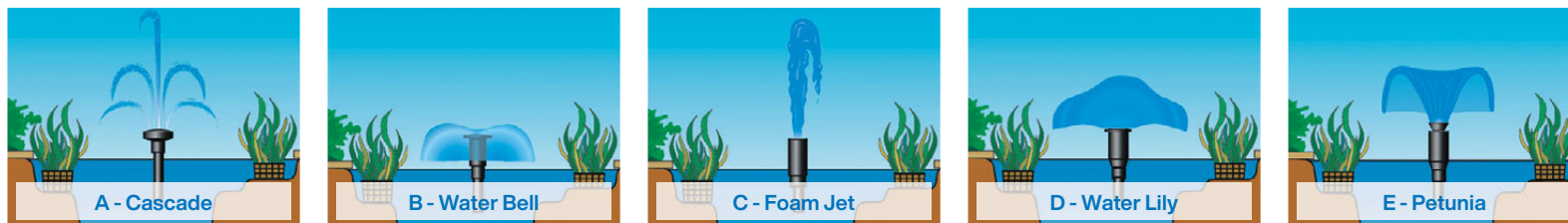

**D RCD981 RCD Safety Adaptor 230V**

Cuts power automatically if an imbalance is detected between live and neutral (caused by leakage to earth). In the event of general power failure the RCD will not automatically reset meaning anything plugged into it will not automatically restart. No wiring required – plugs straight into 13A socket. No need to remove from socket to reset unit.

<b>Supply:</b>	230V
<b>Maximum Load:</b>	3000W
<b>Maximum Operating Current:</b>	16A
<b>Trip Speed:</b>	50ms
<b>Trip Current:</b>	30mA

**E PC477 77L Wet & Dry Industrial Vacuum Cleaner 2400W Stainless Steel Drum**

High powered, lightweight industrial unit. Stainless steel drum with dual filtration system for superior performance. Features safety shut-off for wet operation. Trolley with swivel drum and two rear locking wheels for easy emptying plus front swivel castors for added manoeuvrability. Supplied with Ø38mm accessory kit, 5m cable with 3-pin plug, cloth and cartridge filters. Fitted with twin motors offering superior vacuuming power. Particularly suitable for industrial and commercial applications where extra capacity and power are required. Optional front mounting squeegee available.

<b>Motor Power:</b>	2 x 1200W
<b>Supply/Plug Type:</b>	230V/3-Pin
<b>Power Supply Cable Length:</b>	5m
<b>Airflow:</b>	174m <sup>3</sup> /hr
<b>Drum Size:</b>	77L
<b>Weight:</b>	39kg
<b>Vacuum Accessories Diameter:</b>	Ø38mm
<b>Filter Type:</b>	Cartridge, Cloth
<b>Replacement Cartridge Filter:</b>	PC477.PF
<b>Replacement Cloth Filter Assembly:</b>	PC477.CF
<b>Optional Squeegee:</b>	PC477AK1



**A NEW**

**8L**



**A DST08**  
**8L Dust Suppression Water Tank**

Effective at suppressing dust while using cut-off saws, bench saws and floors saws in all working environments. Automatic pressure release valve stops pressure building higher than 3bar for optimum use. Includes 3m hose with quick release coupling.

**B**

**14L**



**B DST14**  
**14L Dust Suppression Water Tank**

Effective at suppressing dust while using cut-off saws, bench saws and floor saws in all working environments. Automatic pressure release valve stops pressure building higher than 3bar for optimum use. Before use 20 full pumps will allow for 1-1½ minutes of operation. Includes attached strap for easy transportation, a 3m hose with quick release coupling and a spare set of washers.

**C NEW**

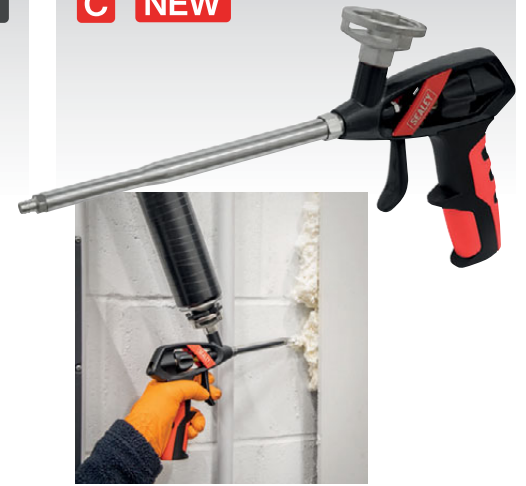

**C FG001**  
**Foam Gun for Expanding Foam Cartridges**

A top quality metal gun for use with gun grade polyurethane expanding foams. Screws onto the canister for quick and easy application. Easy adjustable flow control. Stainless steel barrel and needle.

**D NEW**

**26L**

**HEAVY DUTY**



**D SFT26H**  
**26L Heavy-Duty Flexi Tub with Metal Handle - Black**

Manufactured from heavy-duty polyethylene with a versatile, flexible construction. Ideal for a wide range of domestic and industrial applications.

**Dimensions (W x D x H):** 400 x 355 x 325mm  
**Base Size:** Ø265mm

**E**

**40L**

**HEAVY DUTY**



**F-H**

**NEW**



**30L**

**40L**

**65L**

**HEAVY DUTY**

**E-H SEE BELOW**  
**Heavy-Duty Flexi-Tubs**

Manufactured from heavy-duty polyethylene with a versatile, flexible construction. Ideal for a wide range of domestic and industrial applications.

	<b>E</b>	<b>F</b>	<b>G</b>	<b>H</b>
<b>Model No:</b>	SFT40Y	SFT30	SFT40	SFT65
<b>Colour:</b>	Yellow	Black	Black	Black
<b>Maximum Capacity:</b>	40L	30L	40L	65L
<b>Dimensions (W x D x H):</b>	520 x 450 x 345mm	470 x 425 x 275mm	485 x 460 x 380mm	630 x 550 x 380mm
<b>Base Size:</b>	Ø340mm	Ø360mm	Ø350mm	Ø440mm

**I 65L**



**I WB65**  
**65L Galvanized Wheelbarrow**

Lightweight galvanized steel wheelbarrow ideal for a wide range of gardening and light construction applications, as well as general domestic use. Constructed with strong tubular steel frame and rubber gripped handles. Fitted with Ø340mm pneumatic tyre.

**J 85L**



**J WB85**  
**85L Wheelbarrow**

Manufactured from heavy-duty composite material. Ideal for a wide range of gardening and light construction tasks as well as general domestic use. Constructed with strong tubular steel frame and rubber grip handles. Fitted with Ø405mm pneumatic tyre.

**K NEW 100L**



**K WBR01**  
**100L Heavy-Duty Wheelbarrow**

Heavy-duty wheelbarrow ideal for construction as well as general domestic use. Our wheelbarrows use air filled pneumatic tyres, perfect for absorbing impact and are ideal for use on uneven surfaces and rough terrain. Constructed with strong tubular steel frame and rubber gripped handles. Wheel Size: Ø390mm.





**3-3.6m Spread**  
**16L Capacity**  
**27kg Capacity**



**3-3.6m Spread**  
**29L Capacity**  
**37kg Capacity**



**3-3.6m Spread**  
**60L Capacity**  
**57kg Capacity**

**A SPB27W**  
**27kg Lightweight Walk Behind Broadcast Spreader**

Manufactured with a strong tubular steel frame and polypropylene dispensing hopper. Fitted with nylon gear and adjustable feed system. Sprays in 360° motion to cover a large area. Suitable for a variety of horticultural agents including grit, seed, salt, fertilizer and weedkiller.

Capacity (Weight):	27kg
Capacity (Volume):	16L
Spread:	3-3.6m
Weight:	5.5kg
Dimensions (W x D x H):	460 x 810 x 765mm

**B SPB37W**  
**37kg Walk Behind Broadcast Spreader**

Manufactured with a strong tubular steel frame and polypropylene dispensing hopper. Fitted with nylon gear, rain cover, pneumatic tyres and adjustable feed system. Includes hopper screen to ease spreader flow and filter out unwanted contaminants. Sprays in 360° motion to cover a large area. Suitable for a variety of horticultural agents including grit, seed, salt, fertilizer and weedkiller.

Capacity (Weight):	37kg
Capacity (Volume):	29L
Spread:	3-3.6m
Weight:	10.4kg
Dimensions (W x D x H):	535 x 940 x 820mm

**C SPB57W**  
**57kg Walk Behind Broadcast Spreader**

Manufactured with a strong tubular steel frame and polypropylene dispensing hopper. Fitted with nylon gear, rain cover, pneumatic tyres and adjustable feed system. Includes hopper screen to ease spreader flow and filter out unwanted contaminants. Sprays in 360° motion to cover a large area. Suitable for a variety of horticultural agents including grit, seed, salt, fertilizer and weedkiller.

Capacity (Weight):	57kg
Capacity (Volume):	60L
Spread:	3-3.6m
Weight:	17.6kg
Dimensions (W x D x H):	790 x 1060 x 890mm



**3-3.6m Spread**  
**29L Capacity**  
**37kg Capacity**



**3-3.6m Spread** **60L Capacity** **57kg Capacity**



**3-3.6m Spread** **88L Capacity** **80kg Capacity**

**D SSB37W**  
**37kg Walk Behind Stainless Steel Broadcast Salt Spreader**

Manufactured with a strong tubular steel frame and polypropylene dispensing hopper. Features corrosion resistant stainless steel feed system ideal for spreading salt and grit. Fitted with nylon gear and adjustable feed system. Sprays in 360° motion to cover a large area. Suitable for a variety of horticultural agents including grit, seed, salt, fertilizer and weedkiller.

Capacity (Weight):	37kg
Capacity (Volume):	29L
Spread:	3-3.6m
Weight:	10.44kg
Dimensions (W x D x H):	550 x 940 x 860mm

**E-F SEE BELOW**  
**Tow Behind Broadcast Spreaders**

Manufactured with a strong tubular steel frame and polypropylene dispensing hoppers. Pin hitch design attaches to ride-on lawnmowers, can be converted to ball hitch using Model No. TB36\*. Fitted with aluminium gear, rain cover, pneumatic tyres and adjustable feed system. Includes hopper screen to ease spreader flow and filter out unwanted contaminants. Sprays in 360° motion to cover a large area. Suitable for a variety of horticultural agents including grit, seed, salt, fertilizer and weedkiller.

	<b>E</b>	<b>F</b>
Model No:	SPB57T	SPB80T
Capacity (Weight):	57kg	80kg
Capacity (Volume):	60L	88L
Spread:	3-3.6m	3-3.6m
Weight:	11.6kg	24kg
Dimensions (W x D x H):	680 x 980 x 790mm	880 x 1350 x 965mm

\*Some modification may be required

**A**



**1070mm Spread**

**80kg Capacity**

**80L Capacity**

**A SPD80T**

**80kg Tow Behind Drop Spreader**

Manufactured with a strong tubular steel frame and polypropylene dispensing hopper. Pin hitch design attaches to ride-on lawnmowers, can be converted to ball hitch using Model No. TB36\*. Fitted with pneumatic tyres and adjustable feed system. Designed to spread in a continuous line providing a more accurate application. Suitable for a variety of horticultural agents including grit, seed, salt, fertilizer and weedkiller.

<b>Capacity (Weight):</b>	80kg
<b>Capacity (Volume):</b>	80L
<b>Spread:</b>	1070mm
<b>Weight:</b>	19kg
<b>Dimensions (W x D x H):</b>	1350 x 910 x 550mm

\*Some modification may be required

**B**



**25L Capacity**

**27kg Capacity**

**560mm Spread**

**B SPD27W**

**27kg Walk Behind Drop Spreader**

Manufactured with a strong tubular steel frame and polyethylene dispensing hopper. Fitted with adjustable feed system to control feed quantities. Designed to spread in a continuous line providing a more accurate application. Suitable for a variety of horticultural agents including grit, seed, salt, fertilizer and weedkiller.

<b>Capacity (Weight):</b>	27kg
<b>Capacity (Volume):</b>	25L
<b>Spread:</b>	560mm
<b>Weight:</b>	5kg
<b>Dimensions (W x D x H):</b>	740 x 810 x 775mm

**C SSA2**

**Single Nozzle Broadcast Lance**

Single broadcast lance provides a wide 4.3m spray pattern. Suitable for use with Model No. SS37 (see below). Supplied with polyvinyl hose and all mounting equipment. Also suitable as replacement broadcast nozzle for Model No's SS60 and SS98 (see below).

<b>Maximum Spray Reach:</b>	4.3m
<b>Applications:</b>	SS37, SS60, SS98

**C**

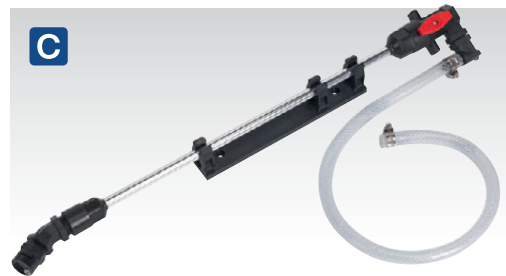

**D**



**37L 12V**

**D SS37**

**37L 12V Spot Sprayer**

Spot sprayer suitable for attaching to most all-terrain vehicles. Powered by 12V battery or connected via 12V supply on ATV/Quad Bikes. Quiet running diaphragm pump is pressure activated, producing a smooth flow from the tank. Supplied with trigger operated lance providing controlled application. Features remote operated on/off switch and battery clips. Tank is manufactured using chemical resistant material and is fitted with tank drainage spout. Tank also features extra-thick walls and is UV-stabilized to prevent fading. Suitable for use with a variety of different agents including weedkiller, de-icer and for spraying fertilizer.

<b>Tank Capacity:</b>	37L
<b>Maximum Flow Rate:</b>	3.8L/min
<b>Maximum Pressure:</b>	40psi
<b>Maximum Spray Reach:</b>	4.3m
<b>Hose Length:</b>	4.5m
<b>Dimensions (W x D x H):</b>	711 x 305 x 279mm
<b>Weight:</b>	4.1kg

**E**



**60L 12V**

**E-F SEE BELOW**

**12V Spot/Broadcast Sprayers**

Spot/broadcast sprayers supplied with tie down straps to attach to most all terrain vehicles. Powered by 12V battery or connected via 12V supply on ATV/Quad Bikes. Quiet running diaphragm pump is pressure activated producing a smooth flow from the tank. Supplied with trigger operated lance providing controlled application and broadcast lance for hands-free operation. Features remote operated on/off switch and battery clips. Tank is manufactured using chemical resistant material and is fitted with tank drainage spout for draining unwanted contents. Tank also features extra-thick walls and is UV-stabilized to prevent fading. Suitable for use with a variety of different agents including weedkiller, de-icer and for spraying fertilizer.

<b>Model No:</b>	<b>SS60</b>	<b>SS98</b>
<b>Tank Capacity:</b>	60L	98L
<b>Maximum Flow Rate:</b>	8.3L/min	8.3L/min
<b>Maximum Pressure:</b>	70psi	70psi
<b>Maximum Spray Reach:</b>	4.3m	4.3m
<b>Hose Length:</b>	4.5m	4.5m
<b>Dimensions (W x D x H):</b>	864 x 368 x 419mm	864 x 368 x 622mm
<b>Weight:</b>	8.4kg	9.9kg

**F**



**98L 12V**



**A-C NEW**



**A-C SEE BELOW**

**Coal Shovels**

Coal shovel range comes in sizes 4", 6" and 8". Ideal for removing hot ashes or coals from fireplaces or wood stoves.

	<b>A</b>	<b>B</b>	<b>C</b>
<b>Model No:</b>	SS07	SS08	SS09
<b>Blade Size:</b>	4"	6"	8"
<b>Length:</b>	330mm	410mm	370mm
<b>Handle:</b>	228mm	185mm	228mm

**D**



**D SS03 590mm Folding Shovel**

Manufactured with a strong nylon handle and solid carbon steel head, powder coated for resistance to corrosion. Ideal for use in adverse weather conditions. Lightweight and durable design featuring twist-and-tighten locking system for easy assembly. Supplied in pouch for easy storage.

<b>Length (Folded):</b>	240mm
<b>Length (Unfolded):</b>	590mm
<b>Blade Size:</b>	155 x 220mm

**E**

**HEAVY DUTY**

800mm

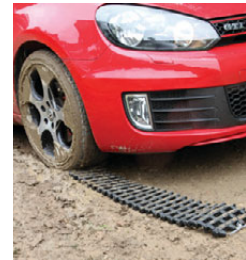
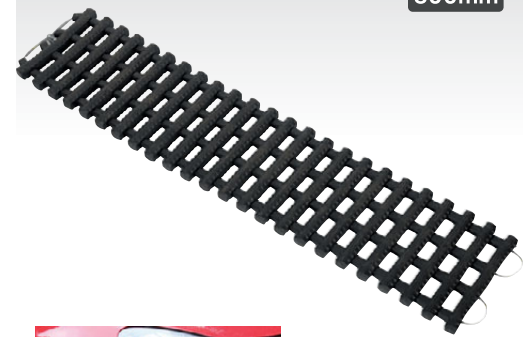

**E VTR02 800mm Vehicle Traction Track**

Heavy-duty vehicle traction track designed to prevent wheels spinning on snow, sand and mud. Flexible PVC design allows track to sit smooth against uneven surfaces. Fitted with galvanized steel cable and deep ribbed slatted cleats providing maximum grip. Each track can support a maximum safe working load of 3.5 Tonne. Supplied as singles in canvas storage pouch.

<b>Length:</b>	800mm
<b>Width:</b>	220mm
<b>Safe Working Load:</b>	3.5 Tonne

**F**

**HEAVY DUTY**



**G**

**HEAVY DUTY**



**F-G SEE BELOW**

**General-Purpose Shovels with 900mm Handle**

Heavy-duty spark-free shovels with YD handle. Large 365 x 470mm composite head ideal for use with snow, wood chips, compost, grain and debris.

	<b>F</b>	<b>G</b>
<b>Model No:</b>	SS01	SS02
<b>Length:</b>	1370mm	1370mm
<b>Handle:</b>	900mm	900mm
<b>Shaft Type:</b>	Metal	Hardwood
<b>Blade Size:</b>	365 x 470mm	365 x 470mm

**H**

**NEW**

**HEAVY DUTY**



**H SS10 General-Purpose Polypropylene Shovel with 690mm Handle**

Heavy duty one-piece polypropylene shovel with extra wide blade and D-shaped handle for comfort during use. Ideal for use with wood chips, sand, snow, grain, stable/farm waste and compost.

<b>Length:</b>	1100mm
<b>Handle:</b>	690mm
<b>Shaft Type:</b>	Polypropylene
<b>Blade Size:</b>	330 x 460mm

**I**



**I SH710 Shovel with 710mm Handle**

Tough, pressed carbon steel shovel head tempered for extra strength.

<b>Length:</b>	1020mm
<b>Handle:</b>	710mm
<b>Shaft Type:</b>	Hardwood Ash
<b>Blade Size:</b>	340 x 260mm



**A-B SEE BELOW**

**Snow Shovels**

Lightweight and durable shovels with forged metal shaft and YD handle. Ideal for use in adverse weather conditions.

	<b>A</b>	<b>B</b>
<b>Model No:</b>	SS05	SS06
<b>Length:</b>	1360mm	1440mm
<b>Blade Size:</b>	395 x 310mm	545 x 380mm

**C NEW**



**C SFS01**

**1200mm Long Handled Fencing Spade**

Professional carbon steel fencing spade designed for digging post holes. Overall size of 1.5m helps to reduce back strain and offers long reach for added depth. Spade is very versatile and can break all ground types and chop through roots.

<b>Length:</b>	1500mm
<b>Handle:</b>	1200mm
<b>Blade Sizes:</b>	300 x 120mm Bottom, 300 x 170mm Top



**110L Capacity**

**D GB01**

**110L Grit & Salt Storage Box**

Manufactured from hard-wearing polyethylene. Ideal for indoor and outdoor storage of grit, sand and salt. Angled lid forces water to run off, keeping contents dry. Features large opening for easy-access.

<b>Dimensions (W x D x H):</b>	650 x 500 x 570mm
<b>Weight:</b>	8kg

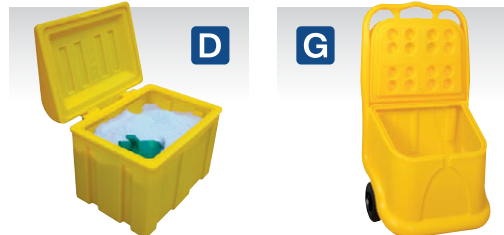

**G**

**75L Capacity**



**G GB04**

**75L Grit/Salt Mobile Storage Cart**

Manufactured from hard-wearing chemical and weather resistant polyethylene. Features a 75L capacity storage tank ideal for a variety of materials including grit, salt, sand, logs and oil absorbents. Fitted with composite wheels and ergonomic handle for easy manoeuvrability. Large clip securely holds lid open to provide easy-access. Angled lid forces water to run off, keeping contents dry.

<b>Dimensions (W x D x H):</b>	435 x 590 x 1070mm
<b>Weight:</b>	11kg



**130L Capacity**



**200L Capacity**

**E-F SEE BELOW**

**Grit & Salt Storage Boxes**

Manufactured from hard-wearing polyethylene. Ideal for indoor and outdoor storage of grit, sand and salt. Angled lid forces water to run off, keeping contents dry. Features large opening for easy-access. Compatible with most pallet trucks.

	<b>E</b>	<b>F</b>
<b>Model No:</b>	GB02	GB03
<b>Capacity:</b>	130L	200L
<b>Dimensions (W x D x H):</b>	850 x 500 x 750mm	1005 x 590 x 855mm
<b>Weight:</b>	12kg	16kg



## A LS450H

### Horizontal Foot Operated Log Splitter

Heavy-duty steel construction with adjustable foot pedal, splits firewood easily with each step on the foot pedal exerting a splitting force of up to 1.2 Tonne. Minor assembly required. Folds down for easy storage.

Maximum Log Diameter:	Ø250mm
Maximum Log Length:	450mm
Maximum Load Pressure:	1.2 Tonne
Overall Size (W x D x H):	370 x 835 x 520mm
Weight:	9.5kg

A

1.2 Tonne



B

**HEAVY DUTY**



## B LC300ST

### Heavy-Duty Log Stand Ø230mm Capacity

Easy to assemble and safe to use. Folds down flat for storage and transportation. Holds logs up to Ø230mm. Compatible with chainsaw use for ease and safety.

Overall Size Open (W x D x H):	440 x 480 x 930mm
Overall Size Folded (W x D x H):	440 x 90 x 690mm
Maximum Log Diameter:	Ø230mm
Weight:	10.3kg

C



C NEW



## C PHA100

### 2-Stroke Petrol Earth Auger

Drills holes up to 800mm deep and 200mm wide, ideal for seating trees, garden posts and fence supports into the ground. 52cc 2hp Petrol motor. Three different diameter bore sizes - Ø100, 150 or 200mm. Twin ergonomic handles for comfort and ease of use (by one or two people). Auger brake automatically stops the bit from turning if hard underground impediment is hit.

Engine Type:	Single Cylinder Air Cooled 2-Stroke
Engine Capacity:	52cc
Fuel Tank:	2-Stroke 25:1 (1.2L)
Fuel Consumption:	0.85L/hr 850g/hr
Max Engine Speed:	8500rpm
Maximum Power:	2hp 7500rpm
Maximum Torque:	1.85Nm
Noise Rating:	116dB(A) Guaranteed value
Vibration/Uncertainty (Idling):	5,948m/s <sup>2</sup> (main handle), 6,812m/s <sup>2</sup> (auxiliary handle), K=1.5m/s <sup>2</sup>
Vibration/Uncertainty (Racing):	20,520m/s <sup>2</sup> (main handle), 20,984m/s <sup>2</sup> (auxiliary handle), K=1.5m/s <sup>2</sup>
Weight:	9kg (without auger bit)

D



Ø100mm



## D PPD100

### Ø100mm 2-Stroke Petrol Post Driver

Heavy-duty and easy-to-use post driver, designed to knock posts up to Ø100mm diameter in to the ground. Powered by a lightweight, compact and powerful 2-stroke 52cc air cooled single cylinder engine. Recoil start and a fuel capacity of 1.3L. Supplied with three sets of post rings: 20 x Ø49mm, 50 x Ø69mm, 70 x Ø100mm, allowing the machine to be used with a wide range of diameter posts. Supplied complete with storage case with integral wheels for ease of transport, as well as full tool kit and fuel mixing container.

Weight:	30.1kg
---------	--------



**A-B SEE TABLE**

**Log Splitters**

Safe and easy way to split logs, offering continuous sizing. Splits logs almost instantly upon contact, keeping labour and work time to a minimum. Features mesh cage and a two-hand operation push-button and lever for safe operation. Supplied with wheels for easy manoeuvrability. Optional Stand Model No. LS520HST available separately (see table).

	<b>A</b>	<b>B</b>
<b>Model No:</b>	LS370H	LS520H
<b>Maximum Log Diameter:</b>	Ø250mm	Ø250mm
<b>Maximum Log Length:</b>	370mm	520mm
<b>Maximum Load Pressure:</b>	4 Tonne	5 Tonne
<b>Motor Power:</b>	1500W	2200W
<b>Supply/Plug Type:</b>	230V/3-Pin	230V/3-Pin
<b>Power Supply Cable Length:</b>	1.8m	1.8m
<b>Overall Size (W x D x H):</b>	750 x 250 x 420mm	940 x 270 x 510mm
<b>Weight:</b>	37kg	42kg



**C LS520HST**

**Horizontal Log Splitter Stand for LS370H & LS520H**

Powder coated steel frame for added longevity. Suitable for use with both Sealey Model No's LS370H and LS520H Log Splitters. Safely elevates log splitter to a more ergonomically suitable working height allowing its use without the need to bend down. Either log splitter, once mounted on the stand, can have its wheels transferred to the stand for easy manoeuvrability.

<b>Height (without Log Splitter):</b>	740mm
<b>Height (with Model No. LS370H):</b>	1160mm
<b>Height (with Model No. LS520H):</b>	1250mm
<b>Weight:</b>	7kg

**D LS550V**

**6 Tonne Vertical Type Log Splitter 550mm Capacity**

Safe and easy way to split logs, offering continuous sizing and up to 6 Tonne of pressure. Adjustable wedge allows workpiece to be as near to wedge as possible minimising splitting time. Features a two-hand safety operation, twin pull-in and push-down levers. Fitted with new CE standard guard.

<b>Tier Log Lengths:</b>	100-550mm
<b>Maximum Log Diameter:</b>	Ø300mm
<b>Minimum Log Diameter:</b>	Ø80mm
<b>Vertical Ram Travel:</b>	495mm
<b>Minimum Log Length:</b>	100mm
<b>Maximum Load Pressure:</b>	6 Tonne
<b>Motor Power:</b>	3000W
<b>Supply/Plug Type:</b>	230V/3-Pin
<b>Power Supply Cable Length:</b>	1.8m
<b>Overall Size (W x D x H):</b>	915 x 840 x 1495mm
<b>Weight:</b>	98.2kg



**A NEW**

**SV20 SERIES**

400W

Bar Length 25cm



**D NEW**

**SV20 SERIES**



**E**

**SV20 SERIES**



**H**

**SV20 SERIES**



**K**

**SV20 SERIES**



**SV20 SERIES ONE-BATTERY-FITS-ALL**

For full details of these products, and to view the rest of the SV20 Series One-Battery-Fits-All range, see pages 844 to 872.

**A-C SEE BELOW**

**SV20 Series 25cm Cordless Chainsaw - 20V**

Model No:	Type:	Contents:
<b>A</b> CP20VCHS	Body Only	Chainsaw
<b>B</b> CP20VCHSKIT1	Kit	CP20VCHS - Chainsaw CP20VBP4 - 4Ah Battery CP20VMC - Battery Charger CP1200CB - Canvas Storage Bag
<b>C</b> CP20VCHSKIT	Kit	CP20VCHS - Chainsaw CP20VBP4 - 4Ah Battery (x2) CP20VMC - Battery Charger CP1200CB - Canvas Storage Bag

**D CP20VTP02**

**SV20 Series 20cm Telescopic Cordless Chainsaw Kit - 20V**

Model No:	Type:	Contents:
<b>D</b> CP20VTP02	Kit	CP20VPSH - Chainsaw CP20VTP - Telescopic Pole CP20VBP4 - 4Ah Battery CP20VMC - Battery Charger

**E-G SEE BELOW**

**SV20 Series Cordless Leaf Blower - 20V**

Model No:	Type:	Contents:
<b>E</b> CB20V	Body Only	Leaf Blower
<b>F</b> CB20VCOMBO2	Kit	CB20V - Leaf Blower CP20VBP2 - 2Ah Battery CP20VMC - Battery Charger
<b>G</b> CB20VCOMBO4	Kit	CB20V - Leaf Blower CP20VBP4 - 4Ah Battery CP20VMC - Battery Charger

**H-J SEE BELOW**

**SV20 Series 520mm Cordless Hedge Trimmer - 20V**

Model No:	Type:	Contents:
<b>H</b> CHT20V	Body Only	Hedge Trimmer
<b>I</b> CHT20VCOMBO2	Kit	CHT20V - Hedge Trimmer CP20VBP2 - 2Ah Battery CP20VMC - Battery Charger
<b>J</b> CHT20VCOMBO4	Kit	CHT20V - Hedge Trimmer CP20VBP4 - 4Ah Battery CP20VMC - Battery Charger

**K-M SEE BELOW**

**SV20 Series Cordless Strimmer - 20V**

Model No:	Type:	Contents:
<b>K</b> CS20V	Body Only	Strimmer
<b>L</b> CS20VCOMBO2	Kit	CS20V - Strimmer CP20VBP2 - 2Ah Battery CP20VMC - Battery Charger
<b>M</b> CS20VCOMBO4	Kit	CS20V - Strimmer CP20VBP4 - 4Ah Battery CP20VMC - Battery Charger

Kit contents as listed above and opposite.



CP20VBP2



CP20VMC



CP1200CB



CP20VBP4



**A SS1**  
**1.5L Hand Pressure Sprayer**  
 Ideal for spraying a wide variety of fluids including water, herbicides, pesticides, insecticides, fungicides and solvent-free preservative treatments. Features ergonomic handle and pressure relief valve. Fitted with adjustable nozzle to switch between mist and jet settings.

**B-C SEE BELOW**  
**Pressure Sprayers**  
 Ideal for spraying a wide variety of fluids including water, herbicides, pesticides, insecticides, fungicides and solvent-free preservative treatments. Metal lance with adjustable nozzle which can be switched between mist and jet settings. Fitted with adjustable shoulder strap and pressure relief valve.

	<b>B</b>	<b>C</b>
<b>Model No:</b>	SS2	SS3
<b>Capacity:</b>	5L	8L

**D SS4**  
**16L Backpack Sprayer**  
 Designed for extensive use around the garden, greenhouse and vegetable plots. Suitable for use with most garden chemicals including pesticides, herbicides and solvent-free preservatives. Manufactured from heavy-duty polypropylene. Supplied with four interchangeable spray nozzles and lockable trigger designed for extended use. Features adjustable double padded shoulder straps and large filler cap with integral filter.



**E-G SEE RIGHT**  
**SV20 Series 15L Cordless Garden Backpack Sprayer - 20V**  
 Cordless 20V backpack garden sprayer. This sprayer does not require manual pressing which makes it easy and practical to use. Supplied with three different nozzles to meet different needs and an auto-cut-off function. This backpack sprayer can be used for sterilization, disinfection, weed killing as well as watering flowers and spraying water. It has an added filter to prevent larger particles clogging the machine. With strong durable back straps to ensure comfort when worn. 15L fluid tank with a lance holder clip. Spraying lance including hose is 1.96m.

<b>Tank Capacity:</b>	15L
<b>Hose Length:</b>	800mm
<b>Maximum Pressure:</b>	1.6bar
<b>Maximum Flow Rate:</b>	1.3L/min
<b>Dimensions (W x D x H):</b>	315 x 320 x 580mm
<b>Body Only Weight:</b>	4.5kg

Model No:	Type:	Contents:
<b>E CP20VGBS</b>	Body Only	Backpack Sprayer
<b>F CP20VGBSKIT1</b>	Kit	CP20VGBS - Backpack Sprayer CP20VBP2 - 2Ah Battery CP20VMC - Battery Charger CP1200CB - Canvas Storage Bag
<b>G CP20VGBSKIT</b>	Kit	CP20VGBS - Backpack Sprayer CP20VBP2 - 2Ah Battery CP20VBP4 - 4Ah Battery CP20VMC - Battery Charger CP1200CB - Canvas Storage Bag



## A-C SEE BELOW

### Trade Aluminium Step Ladders EN 131

EN 131 Approved aluminium step ladders with 150kg capacity. Durable lightweight anodised aluminium alloy frame. Deep non-slip steps and wide platform with safety rail allow plenty of leg room for safe standing. Ribbed feet give full floor contact for extra stability.

	A	B	C
<b>Model No:</b>	ASL3S	ASL5	ASL7
<b>Treads:</b>	3	5	7
<b>Weight:</b>	3.7kg	4.7kg	7.3kg
<b>Base Width:</b>	415mm	440mm	520mm
<b>Max. Capacity:</b>	150kg	150kg	150kg
<b>Safe Rail Height:</b>	1220mm	1660mm	2080mm
<b>Platform Height:</b>	610mm	1050mm	1480mm

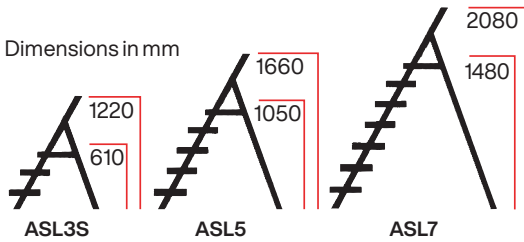

150kg Capacity  
Certified to BS EN 131



175kg Capacity  
BS 2037 Class 1

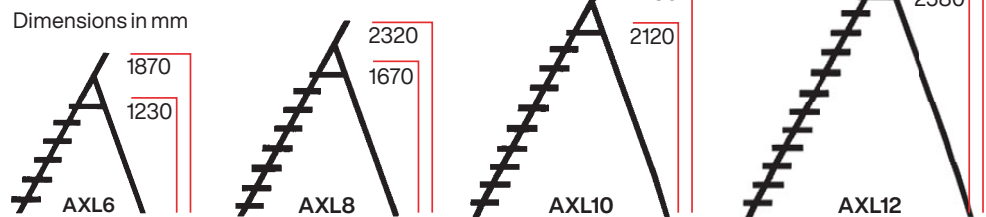

## D-G SEE BELOW

### Industrial Aluminium Step Ladders BS 2037

BS 2037 Class 1 certified professional industrial aluminium platform steps. Rigid box section aluminium with heavy-duty cross brace for extra strength and stability. Double riveted extra-large non-slip treads. Wide platform and high safety rail allow plenty of leg room for safe standing.

	D	E	F	G
<b>Model No:</b>	AXL6	AXL8	AXL10	AXL12
<b>Treads:</b>	6	8	10	12
<b>Weight:</b>	6kg	7.25kg	8.8kg	9.8kg
<b>Base Width:</b>	480mm	510mm	560mm	630mm
<b>Max. Capacity:</b>	175kg	175kg	175kg	175kg
<b>Safe Rail Height:</b>	1870mm	2320mm	2730mm	3190mm
<b>Platform Height:</b>	1230mm	1670mm	2120mm	2580mm

#### IMPORTANT NOTE

There are three standards for ladders in the UK, Class 1, 2 and 3. EN 131 replaced BS 2037 Class 2. Confusion arises with the term 'duty rating', which British Standards arrive at through consideration of frequency and general conditions of use. For consistency we quote maximum static vertical load figures for all our ladders. We only offer trade and industrial ladders. See table to the right for clarification.

Class	Type	Standard	Max. Static Vertical Load	Duty Rating
Class 1	Industrial	BS 2037	175kg	130kg
Class 2	Trade	EN 131	150kg	n/a
Class 3	Domestic	BS 2037	125kg	95kg

**A-C SEE BELOW**

**Trade Aluminium Professional Fold-Flat Step Ladders EN 14183**

EN 14183 Approved 150kg capacity step ladders professionally manufactured with brushed aluminium frames. Features large steps fitted with anti-slip rubber inserts and a large top step for added stability when working at height. Ladders fold down flat for easy storage and transportation. Fitted with four rubber feet for added stability.

	<b>A</b>	<b>B</b>	<b>C</b>
<b>Model No:</b>	APSL2	APSL3	APSL4
<b>Treads:</b>	2	3	4
<b>Safe Rail Height:</b>	919mm	1174mm	1429mm
<b>Platform Height:</b>	467mm	722mm	977mm
<b>Platform Size:</b>	313 x 228mm	313 x 228mm	313 x 228mm
<b>Max. Capacity:</b>	150kg	150kg	150kg

Dimensions in mm

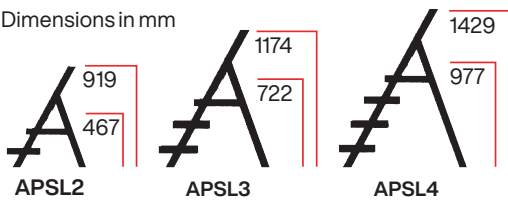

**D-F SEE BELOW**

**Aluminium Extension Combination Ladders EN 131**

Aluminium extension ladders manufactured to EN 131 standards. Ideal for the tradesman, these ladders can be used as a 2-Section or 3-Section extension and as a single ladder, which is ideal for 2-person use. Can be used as a step and extension step ladder where stability and height are needed. Compact size for easy handling and storage. Two larger models suitable to extend up to the apex of a house.

	<b>D</b>	<b>E</b>	<b>F</b>
<b>Model No:</b>	ACL307	ACL3	ACL312
<b>Min. Height:</b>	2m	2.6m	3.4m
<b>Max. Extension:</b>	4.2m	5.9m	7.9m
<b>Max. Reach:</b>	5.1m	6.8m	8.8m
<b>Max. Capacity:</b>	150kg	150kg	150kg
<b>Weight:</b>	9.8kg	12.2kg	16.5kg

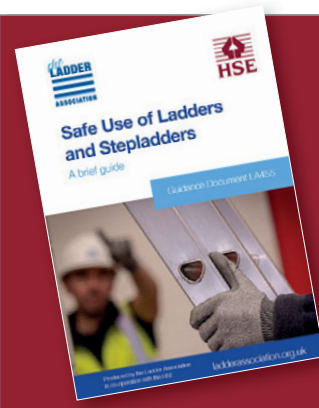
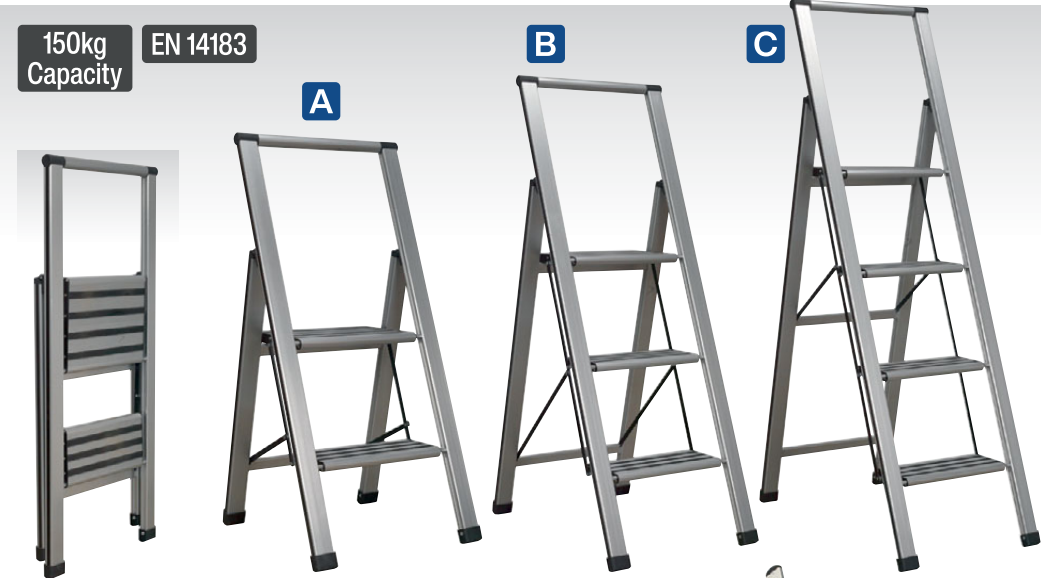

**Health and Safety Executive**



**KEEP SAFE**

Most ladder accidents are caused by human error, not by the ladder failing. The HSE website contains useful information including brochures enabling you to keep safe whilst working with ladders. Go online today to ensure you are safe at work or at home [www.hse.gov.uk](http://www.hse.gov.uk).





**150kg Capacity**  
**BS 14975**

**A LFT03**  
**3-Section Loft Ladder**

Aluminium loft ladder manufactured to BS 14975:2006. Supplied with hand rail and all fixing components for quick and easy installation. 3-Section design enables ladder to fit in smaller areas than standard 2-section ladders.

<b>Loft Opening (W x L):</b>	432 x 508mm
<b>Maximum Height:</b>	3m
<b>Loft Clearance:</b>	1050mm
<b>Maximum Capacity:</b>	150kg



**E SLC2**  
**Ladder Roof Rack Clamps**

Universal fitment for roof racks providing a safe and easy way to secure ladders. Corrosion resistant finish. Suitable for trades where ladders need to be transported safely for on site applications. Supplied with two heavy-duty iron padlocks for security. Made in the UK.

<b>Maximum Width:</b>	365mm
-----------------------	-------



**B LAD002**  
**Ladder Stand-Off**

Aluminium framed stand-off, fits to any ladder. Offers superb stability at the top of a ladder with a wide span of 1000mm. Positions ladder 360mm away from work area. Fitted with rubber feet to help prevent slipping. Supplied with easy installation instructions.

<b>Span Width:</b>	1000mm
<b>Stand-Off:</b>	360mm



**D ASLM1**  
**Anti-Slip Ladder Mat**

Manufactured from a hard-wearing rubber compound, which grips on the smoothest of surfaces. Prevents ladders from slipping and/or sinking into soft ground during use. Helps protect flooring on delicate surfaces. Overall width of 960mm makes this suitable for use with all popular ladders.

<b>Size (W x D x H):</b>	960 x 240 x 55mm
<b>Weight:</b>	5.68kg

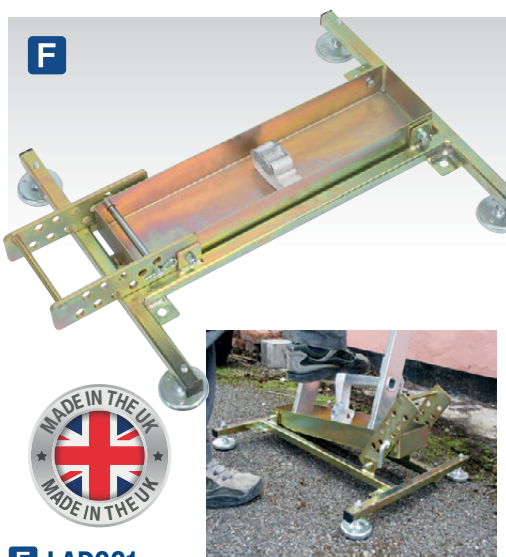

**F LAD001**  
**Ladder Stabiliser**

Safe and easy way to stabilise your ladder on even or uneven surfaces. Yellow phosphate finish for added corrosion resistance. Suitable for trades where ladders need to be used for on site applications. Features heavy-duty metal feet fitted with non-slip rubber pads for added grip and four eyelets for pegging to ground (pegs not included). Tray is adjustable for angle and includes an integral tie down to secure ladder. Increases ladder footprint from 26cm<sup>2</sup> to 3097cm<sup>2</sup>. Made in the UK.

<b>Ladder Tray (W x D):</b>	500 x 125mm
<b>Overall Size (W x D x H):</b>	605 x 515 x 112mm



**C LAD004**  
**2-Way Ladder Stand-Off**

Heat treated aluminium framed ladder stand-off improves stability and fits to any ladder. The "V" Type design can be used on flat surfaces, corners or over down pipes. Fitted with rubber feet to prevent slipping and positions ladder 250-400mm away from wall. Quick and easy to assemble.

<b>Span Width:</b>	700mm
<b>Stand-Off:</b>	250-400mm
<b>Maximum Capacity:</b>	110kg



**G LAD003**  
**Ladder Roof Hooks**

Safe and easy way to access a roof with your ladder. Lightweight aluminium design. Suitable for trades where ladders need to be used for on site applications. Features non-slip composite wheels and 'r'-shape hooks with anti-slip rubber feet. Made in the UK.

<b>Maximum Capacity:</b>	150kg
--------------------------	-------

**A-C SEE BELOW**

**Trade Fibreglass Step Ladders EN 131**

Heavy-duty fibreglass sides with slip resistant aluminium treads. Locking brace bars and anti-slip feet for added stability. Lightweight steps are non-conductive and ideal for site work. Certified to EN 131 standards.

	<b>A</b>	<b>B</b>	<b>C</b>
<b>Model No:</b>	FSL5	FSL7	FSL10
<b>Treads:</b>	4	6	9
<b>Height:</b>	1.4m	1.95m	2.75m
<b>Maximum Capacity:</b>	150kg	150kg	150kg
<b>Weight:</b>	5.7kg	7.6kg	10.6kg



**Important Note:** Check how many steps you are paying for. We only state the number you can use, the top tread is not for standing on but many companies still quote this figure.

**D-F SEE BELOW**

**Trade Aluminium Telescopic Ladders EN 131**

Extends and locks rung-by-rung allowing use at multiple heights. Innovative air dampened function ensures user safety while ladder is lowered. Easy storage and transportation make these ideal for surveyors, tradesmen and domestic use. Lightweight, corrosion resistant aluminium frame. Rubber feet offer increased stability while in use. Manufactured to EN 131 with 150kg capacity.



**D**

2.6m

**E**

3.2m

**F**

3.8m

**150kg Capacity**  
**Certified to BS EN 131**

	<b>D</b>	<b>E</b>	<b>F</b>
<b>Model No:</b>	ATL09	ATL11	ATL13
<b>Treads:</b>	9	11	13
<b>Minimum Height:</b>	720mm	820mm	910mm
<b>Maximum Height:</b>	2630mm	3270mm	3810mm
<b>Maximum Capacity:</b>	150kg	150kg	150kg
<b>Weight:</b>	8kg	11.3kg	14.5kg

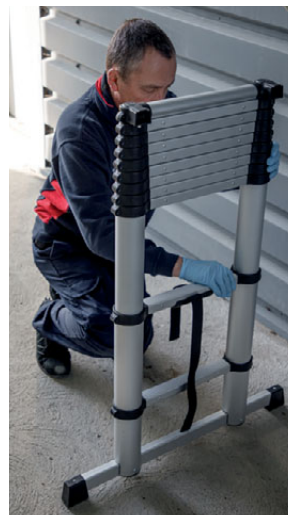



**A AFPL1**

**4-Way Trade Aluminium Folding Platform Ladder EN 131**

EN 131 Certified 4-way, 4-section, aluminium ladder. Six robust auto-latching locking hinges allow for multi-positioning. Can be used as a platform, straight ladder, step ladder or offset ladder. Extra safety provided by 12 reinforced rungs and stabiliser feet. Fitted with extendable legs providing increased climbing height. Supplied with metal platform to use in platform/scaffold position.

A:	B:	C:	D:	E:	F:	Weight:
970	1730	260	970	610	3530mm	12.4kg

**B AFPL2**

**4-Way Aluminium Adjustable Height Folding Platform Ladder EN 131**

EN 131 Certified 4-way, 4-section, aluminium ladder. Six robust auto-latching locking hinges allow for multi-positioning. Can be used as a platform, straight ladder, step ladder or offset ladder. Extra safety provided by 12 reinforced rungs and stabiliser feet. Fitted with extendable legs providing increased climbing height. Supplied with metal platform to use in platform/scaffold position.

A:	B:	C:	D:	E:	F:	Weight:
650/910	1380/1645	340	910	730	2480/3370mm	14.5kg

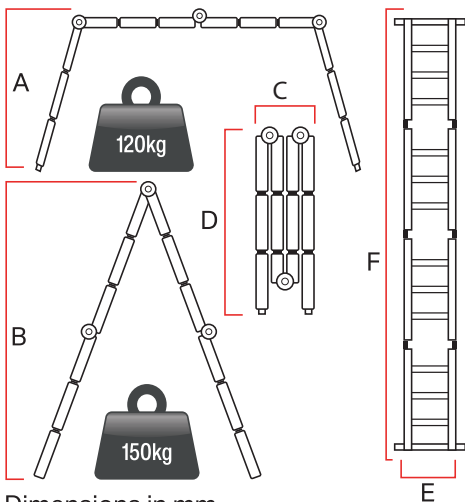

Dimensions in mm.

**C AFPL3**

**4-Way Trade Aluminium Adjustable Height Telescopic Ladder EN 131**

EN 131 Certified 4-way, 4-section, aluminium ladder. Can be used as a straight ladder, step ladder, offset ladder and extension ladder. Fitted with two robust auto-latching locking hinges for multi-positioning. Features extendable legs providing increased climbing height.

Treads:	16
Folded Depth:	190mm
Folded Height:	1405mm
Width:	600mm
<b>Step Ladder Height</b>	
Minimum/Maximum:	1320/2200mm
<b>Offset Ladder Height</b>	
Minimum/Maximum:	1400/2000mm
<b>Extension Ladder Height</b>	
Minimum/Maximum:	2720/4550mm
Maximum Capacity:	150kg
Weight:	15.6kg

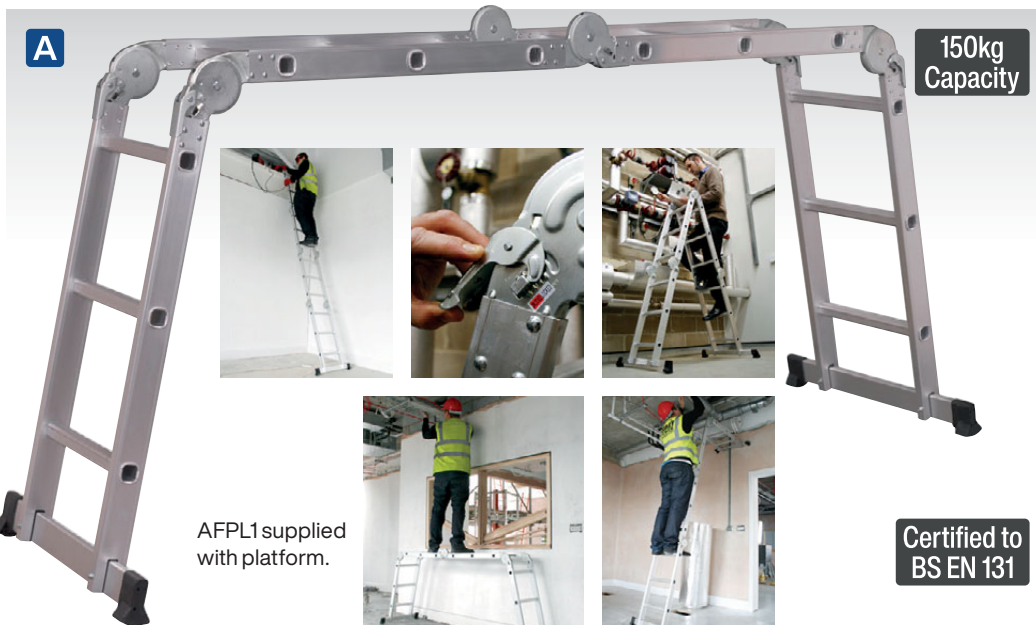

AFPL1 supplied with platform.



AFPL2 supplied with platform.





**A** APS2E

**2-Tread Aluminium Folding Platform EN 131**

EN 131 Approved folding and portable aluminium platform with 150kg capacity. Large, ribbed non-slip platform and treads for safe and easy manoeuvrability. Durable aluminium alloy frame with ribbed feet provides extra stability. Safety locking catches on legs. Folds flat for easy storage and transportation.

Platform Size (W x D):	800 x 300mm
Dimensions (W x D x H):	1250 x 400 x 605mm
Maximum Capacity:	150kg
Weight:	5.6kg



**B** APS2

**2-Tread Trade Aluminium Folding Platform EN 14183**

EN 14183 Approved folding and portable aluminium platform with 150kg capacity. Large, ribbed non-slip platform and treads for safe and easy manoeuvrability. Durable aluminium alloy frame with ribbed feet provides extra stability. Safety locking catches on legs. Folds flat for easy storage and transportation.

Platform Size (W x D):	950 x 300mm
Dimensions (W x D x H):	1280 x 495 x 500mm
Maximum Capacity:	150kg
Weight:	7.2kg

**C** KS5

**Heavy-Duty Platform Safety Step**

Robust, lightweight platform safety step featuring a large 390 x 390mm step surface area. Features 4-way access and anti-slip strips to aid stability when in use. Fitted with four non-slip pads on each corner to prevent movement when in use. Unit is brightly coloured and due to its angled design will not tip over, even when weight is on the edges making this model safe to work on.

Top Step Size:	390 x 390mm
Base Size:	505 x 505mm
Step Heights:	200, 380mm
Maximum Capacity:	150kg

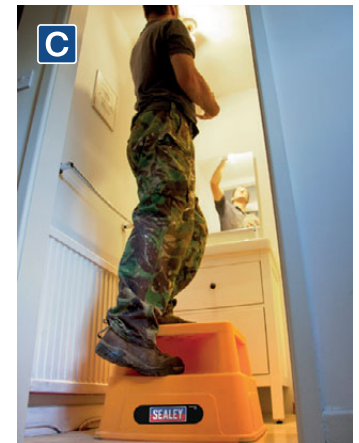

**D-E**

150kg Capacity  
EN 14183



**D-E** SEE BELOW

**Trade Step Stools EN 14183**

EN 14183 Approved steps with 150kg capacity tubular metal construction with composite feet for added stability. Features large anti-slip treads. Foam cushioned hand rail for added comfort. Also suitable as a stool. Folds flat for easy storage and transportation.

	<b>D</b>	<b>E</b>
Model No:	ASL2	ASL23
Treads:	2	3
Top Step Height:	460mm	710mm
Floor Area:	570 x 480mm	640 x 480mm
Maximum Capacity:	150kg	150kg



**F-H** SEE BELOW  
**Kick-Steps**

Heavy-duty construction with non-slip surface. Three spring-loaded wheels allow steps to glide over floor, yet sit down firmly on rubber stops when load is applied.

	<b>F</b>	<b>G</b>	<b>H</b>
Model No:	KS2	KS1	KS4
Material:	Composite	Steel	Composite
Step Heights:	220, 420mm	220, 430mm	210, 430mm
Base Size:	Ø440mm	Ø440mm	Ø430mm
Maximum Capacity:	150kg	150kg	150kg



## A SEE BELOW

### Warehouse Steps

Heavy-duty warehouse steps manufactured from industrial strength aluminium. Fitted with non-slip treads, safety hand rails and cross braced frame for added strength and stability. Features large chequered top platform for extra grip and polyurethane wheels for easy manoeuvrability. Maximum capacity 150kg. Model No's WS8-WS14 supplied flat packed. These products are delivered directly from our factory.

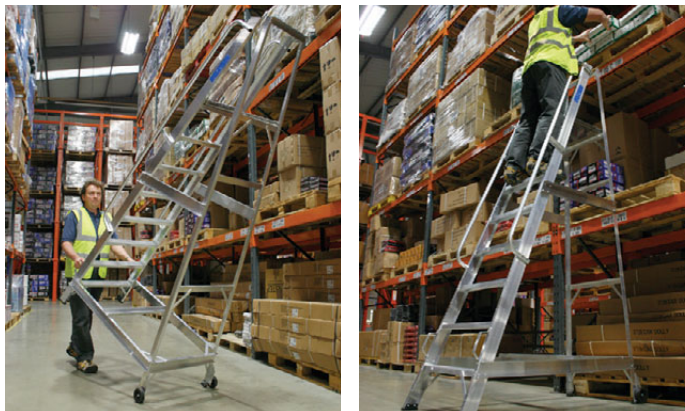

## A



150kg Capacity



Model No:	Treads:	Platform Height:	Overall Height:	Overall Width:	Overall Depth:	Maximum Capacity:	Weight:
WS5	5	1220mm	1880mm	530mm	1070mm	150kg	11.3kg
WS6	6	1450mm	2060mm	560mm	1190mm	150kg	12.7kg
WS7	7	1700mm	2310mm	580mm	1300mm	150kg	14.5kg
WS8	8	1940mm	2540mm	610mm	1470mm	150kg	15.9kg
WS10	10	2410mm	3050mm	660mm	1800mm	150kg	20kg
WS12	12	2900mm	3580mm	710mm	2130mm	150kg	23.6kg
WS14	14	3400mm	4060mm	760mm	2540mm	150kg	26.8kg



These products are manufactured to order and, due to the size, are delivered direct from our factory to all areas within the UK mainland.

Please allow 35-40 working days for delivery and provide the full address, postcode, contact and telephone number for the place of delivery.

Please be aware that additional carriage charges will apply to Scottish postcodes which are **NOT** AB, DD, DG, EH, FK, G, KA, KY, ML & TD for WS models and ALL Scottish postcodes for MSS models.

Please call PURCHASING initially for an individual carriage quote where additional carriage will apply.

For both WS and MSS models deliveries to Northern Ireland, Republic of Ireland, Isle of Man, Isle of Wight, Jersey, Guernsey and other offshore islands have to be individually priced on application and are outside of our normal carriage paid terms.



## B



300kg Capacity



## B SEE BELOW

### Mobile Safety Steps

Robust, round steel tube construction with non-slip step treads. Two fixed wheels and two retractable castors give mobility and allow easy positioning. Castor lock-down lever, on models with five or more treads, restricts tread access as a reminder to retract castors before climbing. 150mm Kick board on three sides of platform.

Model No:	Treads:	Platform Height:	Tread (W x D):	Platform (W x D):	Overall Depth (W x D x H):	Weight:
MSS03	3	750mm	550 x 200mm	550 x 400mm	650 x 760 x 1750mm	28kg
MSS04	4	1000mm	550 x 200mm	550 x 400mm	650 x 910 x 2000mm	32kg
MSS05	5	1250mm	550 x 200mm	550 x 400mm	835 x 1270 x 2250mm	55kg
MSS06	6	1500mm	550 x 200mm	550 x 400mm	835 x 1360 x 2500mm	62kg
MSS07	7	1750mm	550 x 200mm	550 x 400mm	850 x 1450 x 2750mm	70kg
MSS08	8	2000mm	550 x 200mm	550 x 400mm	850 x 1575 x 3000mm	78kg
MSS09	9	2250mm	550 x 200mm	550 x 400mm	850 x 1730 x 3250mm	90kg
MSS10	10	2500mm	550 x 200mm	550 x 400mm	1000 x 1905 x 3500mm	98kg
MSS11	11	2750mm	550 x 200mm	550 x 400mm	1000 x 2070 x 3750mm	105kg
MSS12	12	3000mm	550 x 200mm	550 x 400mm	1000 x 2230 x 4000mm	116kg
MSS13	13	3250mm	550 x 200mm	550 x 400mm	1230 x 2470 x 4250mm	125kg
MSS14	14	3500mm	550 x 200mm	550 x 400mm	1230 x 2630 x 4500mm	130kg
MSS15	15	3750mm	550 x 200mm	550 x 400mm	1320 x 2795 x 4750mm	138kg

## C-D NEW



## C-D SEE BELOW

### Wall Mounting Convex Mirrors

Convex mirrors for improved visibility. Supplied with wall fixing and adjustable swivel joint, allowing for quick and easy positioning. Ideal for use as a safety or security mirror.

Model No:	Diameter:
C CM300	Ø300mm
D CM450	Ø450mm

**A-C SEE BELOW**

**Platform Scaffold Tower EN 1004**

EN 1004 Approved Scaffold Tower System designed to meet the UK PASMA 3T standards. Robust aluminium frame unit with durable corrosion resistance. Heavy-duty platform with trap door for safe access to platform. Model No. SSCL1 can be used as a 2.66m or 3.66m working height platform. This can be increased to 5.5m or 7.15m by fitting extension kit Model No's SSCL3 and SSCL4. Unique design enables the unit to be quickly and easily folded down without tools for transportation or storage. 830mm Depth means unit will pass through most doorways even when partly erected. Hand rails for comfort and safety. Four large Ø125mm castors for easy mobility. Maximum capacity 200kg.

<b>A Model No:</b>	<b>SSCL1</b>
<b>Description:</b>	Base Pack
<b>Maximum Platform Height:</b>	1.66m
<b>Maximum Working Height:</b>	3.66m
<b>Width:</b>	1760mm
<b>Depth:</b>	860mm
<b>Weight:</b>	45kg
<b>B Model No:</b>	<b>SSCL3</b>
<b>Description:</b>	Extension Pack
<b>Maximum Platform Height:</b>	3.41m*
<b>Maximum Working Height:</b>	5.41m*
<b>Width:</b>	1760/3450mm*
<b>Depth:</b>	860mm
<b>Weight:</b>	35kg
<b>C Model No:</b>	<b>SSCL4</b>
<b>Description:</b>	Extension Pack
<b>Maximum Platform Height:</b>	5.17m**
<b>Maximum Working Height:</b>	7.17m**
<b>Width:</b>	1760/3450mm**
<b>Depth:</b>	860mm
<b>Weight:</b>	10kg

\*Only when used with **SSC1**

\*\*Only when used with **SSCL1 & SSCL3**

**A + B + C**

**MAXIMUM REACH 7.17m**

**EN 1004**

**200kg Capacity**



The SSCL Scaffold Tower system features trap door platform access.

**A + B**

**MAXIMUM REACH 5.41m**

**A**

**MAXIMUM REACH 3.66m**

**IMPORTANT** - Base Pack SSCL1 must be purchased first. SSCL3 Can only be fitted to SSCL1 and SSCL4 can only be fitted to SSCL3 and SSCL1. In order to achieve platform height of 1.66m SSCL1 must be ordered. For 3.41m SSCL1 and SSCL3 and for 5.17m SSCL1, SSCL3 and SSCL4.

**D ASCL2**

**4-Way Aluminium Scaffold Ladder EN 131**

EN 131 Approved 4-way scaffold ladder. Two six rung aluminium ladders can be used as extending ladder, single ladders, step ladder or complete scaffolding unit. Supplied with hand rail.

<b>Maximum Capacity:</b>	150kg					
<b>A:</b>	<b>B:</b>	<b>C:</b>	<b>D:</b>	<b>E:</b>	<b>F:</b>	<b>Weight:</b>
2700	1600	1670	1320	950	785mm	14.7kg

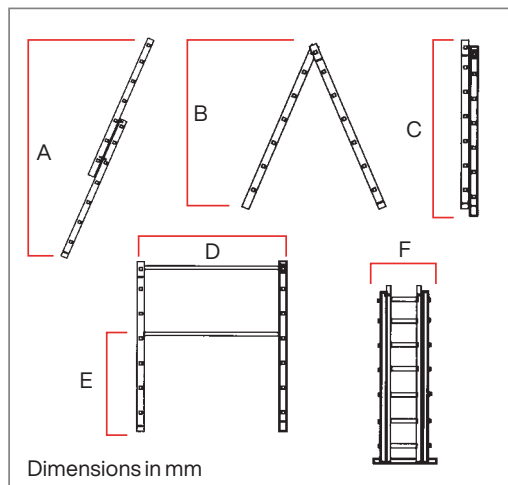

**D**

**150kg Capacity**

**EN 131 Trade**

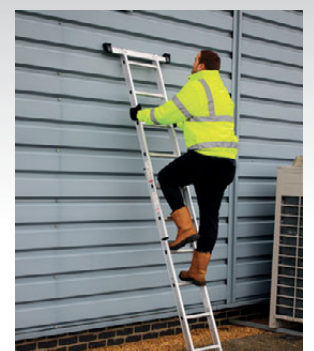



## A-D SEE BELOW

### Towing Plugs

<b>A</b> TB05	12V Towing Plug 7-Pin N-Type Plastic
<b>B</b> TB06	12V Towing Plug 7-Pin N-Type Metal
<b>C</b> TB53	12V Towing Plug 13-Pin Euro Plastic
<b>D</b> TB54	12V Towing Plug 13-Pin Euro Plastic Twin Outlet

## E-F SEE BELOW

### Socket Conversion Adaptors

<b>E</b> TB43	12V 7-Pin N-Type - 13-Pin Euro
Adaptor plugs into towing vehicle's 7-pin N-type socket to allow connection of a caravan or trailer with 13-pin Euro plug.	
<b>F</b> TB44	12V 13-Pin N-Type - 7-Pin N-Type
Adaptor plugs into towing vehicle's 13-pin Euro socket to allow connection of a caravan or trailer with UK standard 7-pin N-type plug.	

## G-I SEE BELOW

### Towing Sockets

<b>G</b> TB07	12V Towing Socket 7-Pin N-Type Plastic
<b>H</b> TB08	12V Towing Socket 7-Pin N-Type Metal
<b>I</b> TB52	12V Towing Socket 13-Pin Euro Plastic



7-Pin Electrics provide the normal/legal lighting requirements for towing.



13-Pin Euro trailer plug is used for supplying all trailer or caravan lighting and give auxiliary power to the other systems such as fridges, internal lighting and charging systems.



## J TB55

### Conversion Lead - 13-Pin Euro To 7-Pin N & S-Type Plugs

Converts 13-pin Euro vehicle socket to 7-pin n-type and 7-pin S-type caravan and trailer socket. Fitted with 200mm cable.

**Type:** 12V 13-Pin Euro to 7-Pin N & S-Type Sockets

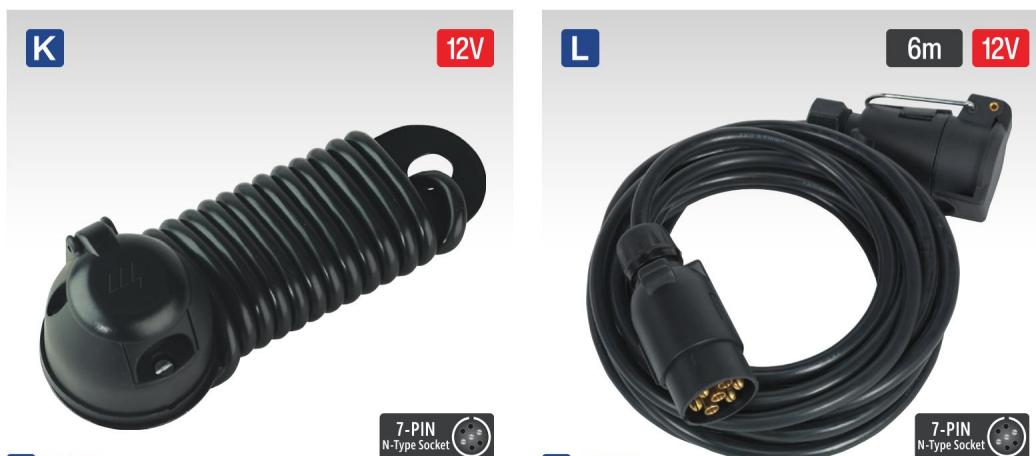

## K TB11

### 12V Towing Socket Assembly N-Type

Complete assembly includes 1.5m 7-core cable with pre-wired 12V 7-pin N-type socket. Metal plate with preformed mounting points at 90mm centres.

## L TB57

### 6m Extension Lead 7-Pin N-Type

6m Extension lead fitted with 12V 7-pin N-type socket and 12V 7-pin N-type plug. Extends existing power supply to your trailer or caravan.



**A-B SEE BELOW**  
**Reflex Reflectors - Packs of 2**  
 Pairs of E-Approved reflectors.

<b>A</b> TB24	Reflex Reflector Red Oblong
<b>B</b> TB17	Reflex Reflector Red Triangle



**E** **WB951LED**  
**12V/24V LED Warning Beacon with 12mm Bolt Fixing**  
 Single point mounting beacon suitable for direct mounting to vehicle roof using a 12mm bolt.



**G** **WB954LED**  
**12V/24V LED Warning Beacon with Magnetic Base**  
 Fully approved for highway use to EN 65. 3-Function control allows for different LED flash configurations. Heavy-duty ABS base. Quick release UV stabilised dome will not fade if exposed to prolonged sunlight. Fitted with six powerful magnets, strong enough to cope with normal road speeds. Supplied with 3m coiled flex and universal vehicle accessory socket plug.



**C** **TB18**  
**12V Rear Square Lamp Cluster**  
 4-Function, E-Approved, square lamp cluster, stop, tail, indicator and numberplate illumination. Supplied with bulbs.  
 Size (W x D x H): 98 x 49 x 98mm



**D** **TB52LED**  
**12/24V LED Front Marker Lamp**  
 Clear front marker light is dual voltage 12/24V for car and commercial. Fitted with 15cm length of 2-core cable. Waterproof and E-Marked.



**F** **TB63**  
**Towing Mirror Extension**  
 Convex towing mirror offers a wider field of vision while towing caravans or trailers. Universal fit will clip onto most wing mirrors. Easy to adjust, both horizontally and vertically. It is a legal requirement to fit an extension mirror when a caravan or trailer obstructs the towing vehicle's vision. Full EU approval.



**H-J SEE BELOW**  
**Mudguards**  
 Trailer mudguards, injection moulded in durable high-density polyethylene.

<b>H</b> TB31	Mudguard for 200mm(8") Wheels
<b>Size (W x D x H):</b>	490 x 140 x 195mm
<b>I</b> TB32	Mudguard for 250mm(10") Wheels
<b>Size (W x D x H):</b>	620 x 180 x 240mm
<b>J</b> TB33	Mudguard for 330mm(13") Wheels
<b>Size (W x D x H):</b>	760 x 220 x 335mm







**A TB12LED**  
**12/24V SMD LED Numberplate Lamp**  
 5 x SMD LED numberplate illumination lamp is waterproof and E-Marked. Dual voltage 12/24V for car and commercial. Lamp supplied with twin cables.



**B TB13LED**  
**12/24V SMD LED Reverse Lamp**  
 19 x SMD LED reverse lamp is waterproof and E-Marked. Dual voltage 12/24V for car and commercial. Transparent lens. Lamp supplied with twin cables.



**C TB14LED**  
**12/24V SMD LED Rear Fog Lamp**  
 19 x SMD LED rear fog lamp is waterproof and E-Marked. Dual voltage 12/24V for car and commercial. Lamp supplied with twin cables.



**D TB18LED**  
**12V LED Rear Square Lamp Cluster**  
 Easily installed modern direct replacement. 5-Function SMD LED rear cluster includes - Stop/Tail/Indicator/Numberplate Illumination/Reflector. R10, CE and E-Marked.



**E TB19LED**  
**12V LED Rear Rectangle Lamp Cluster - Pair**  
 Easily installed modern direct replacement set. 6-Function SMD LED rear cluster set includes - Stop/Tail/Indicator/Numberplate Illumination/Reflector/Rear Fog (left)/Reverse (right). R10, CE and E-Marked.



**F-G SEE BELOW**  
**Universal Light Mounting Brackets Numberplate Fitting**  
 Simple, lightweight solution to fitting driving lamps or LED light bars to the front of a vehicle. Manufactured from lightweight powder coated aluminium. Enables lights to be fitted above or below the numberplate. Ensure that the bracket is securely attached to the vehicle and is capable of supporting the lamps. Make sure the numberplate is clearly visible and not obscured by the lamps or fittings.

Model No:	Size (W x D x H):
<b>F DLB01</b>	365 x 55 x 125mm
<b>G DLB02</b>	590 x 90 x 120mm

**H-I SEE BELOW**  
**LED Worklights**  
 Operating voltage of 10-30V DC. Waterproof rating of IP68. ECE R10 Certified and E-Marked. Suitable replacement for traditional halogen work lights. Powder coated die-cast aluminium housing. Adjustable grade 201 shock-resistant stainless steel bracket. For full range, see page 1176.



**H LED3R**  
**27W SMD LED Round Worklight with Mounting Bracket**  
 9 x 3W Epistar™ high power LEDs. Produces up to 2160 lumens output.

<b>LED Type:</b>	9 x 3W SMD
<b>Supply:</b>	10-30V DC
<b>Lumen Output:</b>	2160lm
<b>Size:</b>	Ø115mm



**I LED4R**  
**42W SMD LED Round Worklight with Mounting Bracket**  
 14 x 3W Epistar™ high power LEDs. Produces up to 3360 lumens output.

<b>LED Type:</b>	14 x 3W SMD
<b>Supply:</b>	10-30V DC
<b>Lumen Output:</b>	3360lm
<b>Size:</b>	Ø115mm

**A** Magnetic **SMD LED**



**A** **TB18LEDMAG**  
**12V LED Magnetic Rear Lighting Set**

Easy-to-install modern direct replacement magnetic trailer lighting set. 5-Function SMD LED rear cluster includes - Stop/Tail/Indicator/Number Plate Illumination/Reflector. Includes 2.5m of 7-core connecting cable and 7.5m main cable fitted with 12V 7-pin N-type plug. R10, CE and E-Marked.

**C** **TB3/2**  
**3ft Bicycle Carrier Lighting Board with 2m Cable**

Composite 3ft board fitted with 2m of 7-core cable and 12V N-type plug. Includes two E-Approved reflectors and two 4-function lamp clusters (stop, tail, indicator and numberplate illumination light).

**Important: Standard trailer boards should not be used in conjunction with cycle carriers.**



**D-E** **SEE RIGHT**  
**12V Trailer Boards with Fog Light**

**D** **TB46/6**  
Composite board fitted with 6m of 7-core cable and 12V N-type plug. Includes two E-Approved reflective triangles, two 4-function lamp clusters (stop, tail, indicator and numberplate illumination light) and fog lamp. Pre-drilled mounting points (905mm centres).

**Size (W x H):** 1370mm(4ft 6") x 139mm(5.5")

**E** **TB46/6LED**  
Composite board fitted with 6m of 7-core cable and 12V 7-pin N-type plug. Includes two E-Approved triangle reflectors, two 5-function SMD LED rear square clusters (Stop/Tail/Indicator/Numberplate Illumination/Reflector) and fog light. Can easily adapt to 13-pin using Model No. TB44.

**Size (W x D x H):** 1370mm(4ft 6") x 139mm(5.5")

**F-G** **SEE RIGHT**  
**12V Trailer Boards**

**F** **TB4/5**  
Composite board fitted with 5m of 7-core cable and 12V N-type plug. Includes two E-Approved reflective triangles and two 4-function lamp clusters (Stop/Tail/Indicator/Numberplate Illumination Light). Pre-drilled mounting points (905mm centres).

**Size (W x H):** 1220mm(4ft) x 139mm(5.5")

**G** **TB4/5LED**  
Composite board fitted with 5m of 7-core cable and 12V 7-pin N-type plug. Includes two E-Approved triangle reflectors and two 5-function SMD LED rear square clusters (Stop/Tail/Indicator/Numberplate Illumination/Reflector). Can easily adapt to 13-pin using Model No. TB44.

**Size (W x D x H):** 1220mm(4ft) x 139mm(5.5")

**B** **NEW**  
**SMD LED**  
Magnetic



**B** **TB18LEDW**  
**2pc Wireless SMD LED Trailer Light Set**

Magnetic wireless light clusters give essential light functions with no wiring required. Designed and manufactured for metal trailers, lorries, agricultural machinery, tractors, and other vehicles up to 20m long. EU Plug wiring configurations and vehicles fitted with a 7-pin plug towing trailers. Three functions: brake, indicator, and taillight. 5-Function: brake lights, rear turn signal lights, rear position lights, license plate lights, and return reflectors. Supplied in storage case.







**A TB61**  
**Single Socket Mounting Plate**  
 Single socket mounting plate fits to tow bar/balls. Accepts N-type, S-type and 13-pin Euro sockets. Metal plate with preformed mounting points at 90mm centres.

**B-C SEE BELOW**  
**Bumper Protection Plates**

**B TB301** Stainless Steel Bumper Protection Plate  
 Designed to protect bumpers when coupling up trailer. Stainless steel with pre-drilled mounting points at 90mm centres.

**Size (W x H):** 150 x 180mm

**C TB302** Stainless Steel Bumper Protection Plate  
 Designed to protect bumpers when coupling up trailer. Stainless steel-plate sockets and pre-drilled mounting points at 90mm centres.

**Size (W x H):** 300 x 180mm

**D-E SEE BELOW**  
**Tow-Ball Assemblies & Accessories**

**D TB03E** Ø50mm Tow-Ball  
 Ø50mm Forged, E-Approved, tow-ball designed to comply with European legislation and for fitting to vehicles manufactured after 1st August 1998. Pre-cast mounting points at 90mm centres.

**Size (W x D x H):** 127 x 83 x 120mm

**Ball Size:** Ø50mm

**E TB042** Ø50mm Tow-Ball & Pin Coupling  
 Ø50mm Forged tow-ball with 19mm pin coupling assembly. Suitable for towing trailers of up to 3.5 Tonne. Pre-drilled mounting points at 90mm centres. 25mm Diameter pin. Regulation 55 approved.

**Aperture:** 45mm

**Size (W x D x H):** 140 x 85 x 150mm

**Ball Size:** Ø50mm



**I SCS109**  
**500g Copper Grease Tin**  
 Anti-seize copper grease, protects against rust, oxidation and other corrosion.



STAINLESS STEEL



STAINLESS STEEL



E

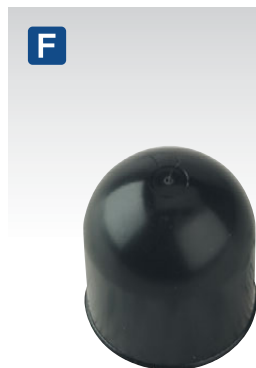

F



G



H

**F-H SEE BELOW**  
**Tow-Ball Covers**

**F TB10** PVC Tow-Ball Cover  
 Black plastic cover for Ø50mm tow-ball, 62mm high. Suitable for use with Model No's. TB03E and TB042.

**G TB101** PVC Tow-Ball Cover  
 Black plastic cover for Ø50mm tow-ball, 62mm high. Suitable for use with Model No. TB03E.

**H TB102** PVC Tow-Ball Cover and Reflector  
 Black plastic cover for Ø50mm tow-ball, 62mm high. Integral reflector increases visibility in poor or dark weather conditions. Suitable for use with Model No. TB03E.



**J TB27**  
**Tow-Ball Bolts & Nuts M16 x 55mm Pack of 2**  
 High tensile M16 x 55mm bolts with nuts and shake-proof washers for fixing tow-ball assemblies.



**A TB371**  
**Jockey Wheel & Ø35mm Clamp**  
**Ø150mm Solid Wheel**  
 Heavy-duty jockey wheel with Ø35mm clamp. Ø150mm Steel wheel with solid rubber tyre. Zinc plated for added corrosion resistance.

Capacity:	80kg
Minimum Height:	515mm
Maximum Height:	725mm
Wheel Size:	Ø150 x 24mm



**B TB37**  
**Jockey Wheel & Ø50mm Clamp**  
**Ø200mm Solid Wheel**  
 Heavy-duty jockey wheel with Ø50mm clamp. Ø200mm Steel wheel with solid rubber tyre. Zinc plated for added corrosion resistance.

Capacity:	150kg
Minimum Height:	580mm
Maximum Height:	810mm
Wheel Size:	Ø200 x 45mm



**C TB372**  
**Jockey Wheel & Ø48mm Clamp**  
**Ø260mm Pneumatic Wheel**  
 Heavy-duty jockey wheel with Ø48mm clamp. Ø260mm Steel wheel with pneumatic tyre. Zinc plated for added corrosion resistance.

Capacity:	150kg
Minimum Height:	630mm
Maximum Height:	860mm
Wheel Size:	Ø260 x 80mm

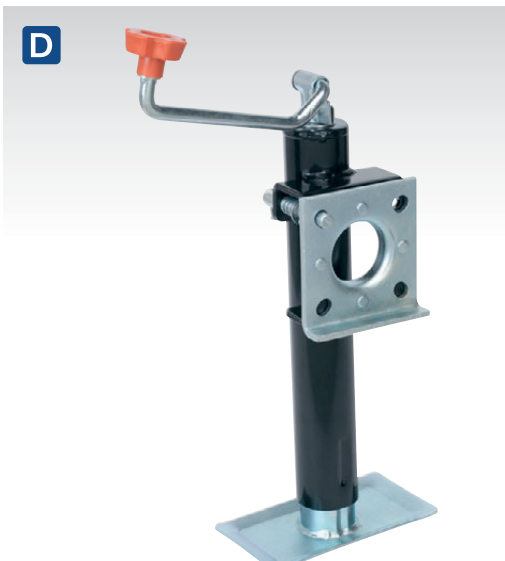

**D TB373**  
**Trailer Jack & Clamp 250mm Travel**  
**900kg Capacity**  
 Heavy-duty trailer jack with swivel mounting. Suitable for handling trailers with heavy nose weight. Integral swivel weld-on mounting.

Minimum Height:	230mm
Maximum Height:	480mm



**E TB36**  
**Ø50mm Towing Hitch - 750kg Capacity**  
 Steel, lockable, towing hitch, E-Approved, accepts Ø50mm tow-ball.



**F TB36/LK**  
**Lock & Key for Ø50mm Hitch**  
 Prevents hitch from being lifted off tow-ball.



**G TB38**  
**Ø50mm Tow-Ball Lock**  
 Universal fitting Ø50mm tow-ball lock expands in coupler to prevent towing away. Quick and easy to install. Non-corrosive.



**H TB45**  
**Ø50mm Tow-Ball Trailer Hitch Lock**  
 Universal fitting Ø50mm tow-ball trailer hitch lock. 12mm Steel bar and cast steel body helps protect against trailer and caravan theft. Easy to install and remove. Supplied with three keys.



**I-J SEE BELOW**  
**Breakaway Cables**  
 A legal requirement. Applies the handbrake on braked caravans and trailers in the event of accidental unhitching. Supplied with heavy-duty split ring and securing clip. PVC Coated for extra durability.

<b>Model No:</b>	<b>Size:</b>
<b>I TB46</b>	1m x 2mm
<b>J TB47</b>	1m x 3mm



**A-B SEE BELOW**

**Ratchet Power Pullers**

These hand operated devices are perfect for moving vehicles, logs, machines and other heavy objects. Vehicles must be in a condition capable of acting as a rolling load within the rated capacity. Both models are delivered ready for use with wire rope already installed and fitted with ratchet safety devices. Model No. HP1500 is equipped with double ratchet safety device and double ratcheting mechanism for applying the load evenly and with minimum effort. Side frames are manufactured in one-piece from best quality steel and zinc chrome plated for long term corrosion resistance. Perfect for marine, industrial and automotive applications.

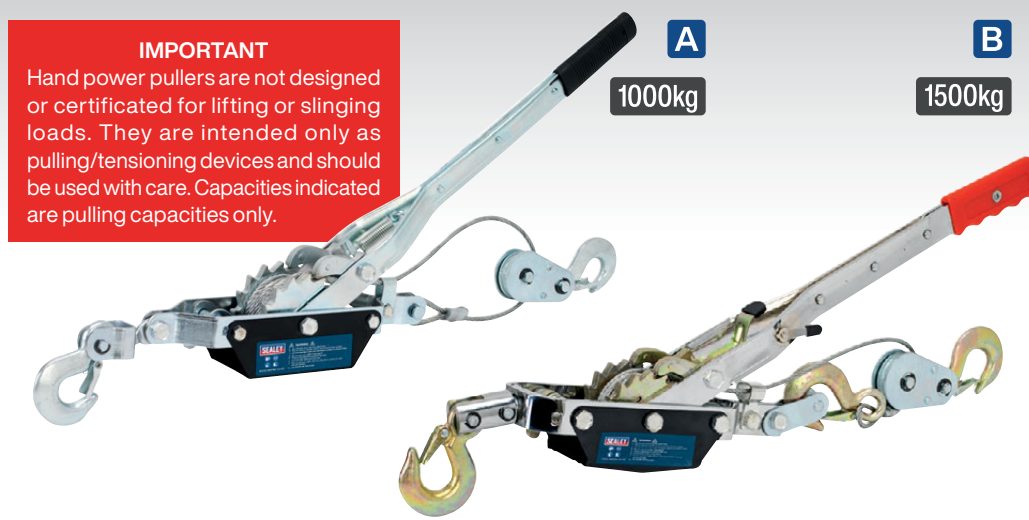

**IMPORTANT**  
Hand power pullers are not designed or certificated for lifting or slinging loads. They are intended only as pulling/tensioning devices and should be used with care. Capacities indicated are pulling capacities only.

	<b>A</b>	<b>B</b>
<b>Model No:</b>	HP1000	HP1500
<b>Capacity:</b>	1000kg	1500kg
<b>Breaking Strain:</b>	2000kg	4000kg
<b>Chassis Thickness:</b>	3mm	6mm
<b>Gear/Pawl Type:</b>	Double/Single	Double/Double
<b>Cable Diameter/Length:</b>	Ø4.8mm/2.6m	Ø5mm/3m
<b>Number of Hooks:</b>	2	3

**C-D SEE BELOW**

**Ratchet Power Pullers**

Hand operated pullers, ideal for lifting and moving vehicles, logs, machines and other heavy objects. All models feature two levers for extra control when pulling or releasing load. Additional quick release lever saves time when adjusting rope length. Supplied with removable lever handle and 20m of wire rope with heavy-duty hook.

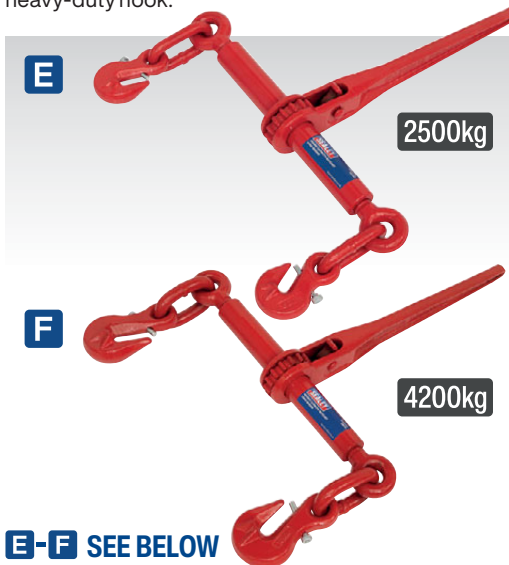

	<b>C</b>	<b>D</b>
<b>Model No:</b>	WRP1600	WRP3200
<b>Rated Capacity:</b>	1600kg	3200kg
<b>Wire Rope Diameter:</b>	Ø11mm	Ø16mm
<b>Wire Rope Length:</b>	20m	20m
<b>Weight:</b>	27kg	48kg

**E-F SEE BELOW**

**Ratchet Load Binders**

Manufactured from heat treated, drop-forged steel for added strength. Suitable for clamping, binding, anchoring and tying down large loads. Ideal for farmers and commercial drivers. Fitted with 354mm handle for extra leverage.

	<b>E</b>	<b>F</b>
<b>Model No:</b>	LB001	LB002
<b>Working Load:</b>	2500kg	4200kg
<b>Breaking Strength:</b>	8636kg	8636kg
<b>Chain Size:</b>	7.9-9.5mm	9.5-12.7mm
<b>Handle Length:</b>	354mm	354mm
<b>Hook:</b>	Double	Double
<b>Weight:</b>	4.8kg	5.9kg



**G WRD01**  
**Wire Rope Protective Cover**

Wire rope dampener is designed to absorb winch and puller rope energy if rope failure occurs when pulling a heavy load. Heavy-duty vinyl with silver reflective tape for night-time visibility.

<b>Size (W x H):</b>	500 x 450mm
<b>Weight:</b>	0.9kg



**H TB40**  
**E-Approved Warning Triangle**

High quality, compact, folding warning triangle supplied in tough composite case. Legal requirement in many countries. Suitable for use following accidents/breakdowns. Complies with ECE R27 and is 'E' marked.

<b>Size (W x H):</b>	410 x 440mm
----------------------	-------------

**A-F SEE BELOW**  
**Manual Geared Winches**

Manufactured from hardened steel with a heavy plate chassis. Features a single or double gear mechanism for smooth and easy operation. Includes manual brake, allowing the user to adjust the restriction placed on the webbing or cable. Suitable for general and recovery operations. Three options available; with empty drum, with wire cable or with webbing strap, all in two capacities.

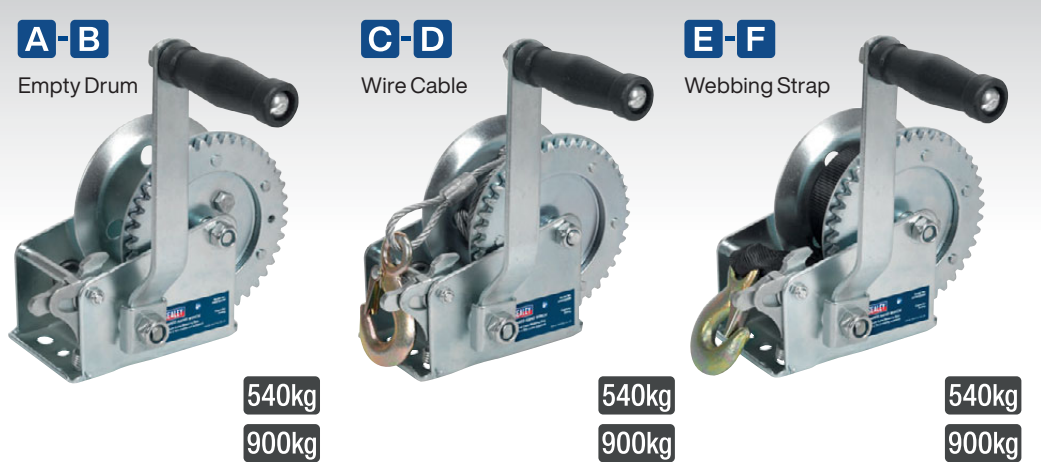

	<b>A</b>	<b>B</b>	<b>C</b>	<b>D</b>	<b>E</b>	<b>F</b>
<b>Model No:</b>	<b>GWE1200M</b>	<b>GWE2000M</b>	<b>GWC1200M</b>	<b>GWC2000M</b>	<b>GWW1200M</b>	<b>GWW2000M</b>
<b>Capacity:</b>	540kg	900kg	540kg	900kg	540kg	900kg
<b>Gear Ratio:</b>	4:1	4:1/8:1	4:1	4:1/8:1	4:1	4:1/8:1
<b>Hub Diameter:</b>	Ø20mm	Ø20mm	Ø20mm	Ø20mm	Ø20mm	Ø20mm
<b>Maximum Cable/Webbing Size:</b>	Ø5.1mm x 10m (cable not included)	Ø5.1mm x 10m (cable not included)	Ø5.1mm x 10m (cable supplied)	Ø5.1mm x 10m (cable supplied)	50mm x 7m (webbing supplied)	50mm x 10m (webbing supplied)
<b>Handle Length:</b>	230mm	230mm	230mm	230mm	230mm	230mm
<b>Weight:</b>	2.1kg	2.5kg	2.6kg	3kg	2.6kg	3kg



**G-H SEE BELOW**  
**Winch Cables**

Model No:	Length:	Tension:	Applications:
<b>G</b> GWEC12	10m	540kg	GWE1200M, GWE1200B
<b>H</b> GWEC20	10m	900kg	GWE2000M



**I-J SEE BELOW**  
**Winch Straps**

Model No:	Strap Length:	Tension:	Applications:
<b>I</b> GWES12	7m	540kg	GWE1200M, GWW1200M
<b>J</b> GWES20	10m	900kg	GWE2000M, GWW2000M



**K SSP33**  
**Anti-Slip Handling Gloves - Pair**

Spun nylon gloves with interlocking criss-cross coating. Ideal for handling cartons, glass and other items with a sheer finish. Conforms to BS EN 420:2003 + A1:2009. Conforms to BS EN 388:2016 Level 113XX.

**L-O SEE BELOW**  
**Manual Geared Winches with Brake**

Hardened steel gear with a heavy plate chassis. Includes an automatic brake system which stops the winch when more than 25kg of force is applied. Features a fully enclosed gearbox. Suitable for general and recovery operations. Available with empty drum, wire cable or webbing strap.

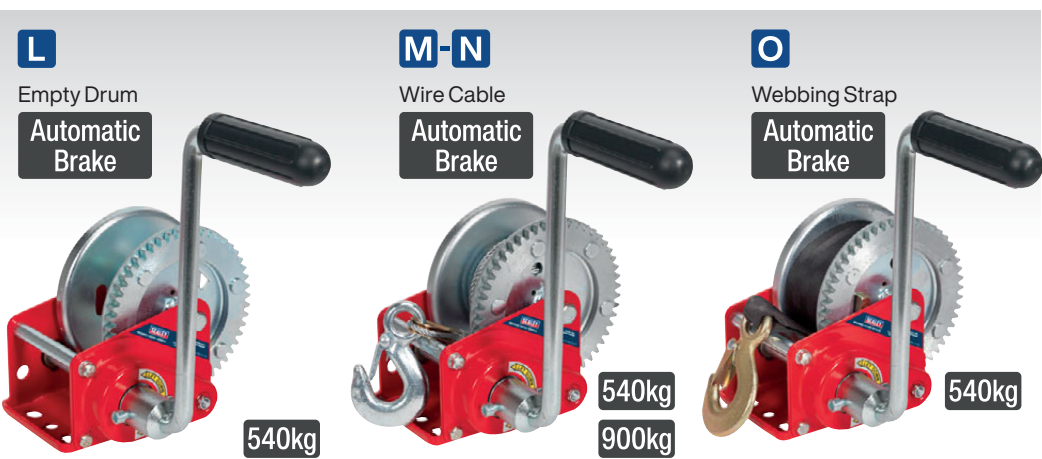

	<b>L</b>	<b>M</b>	<b>N</b>	<b>O</b>
<b>Model No:</b>	<b>GWE1200B</b>	<b>GWC1200B</b>	<b>GWC2000B</b>	<b>GWW1200B</b>
<b>Capacity:</b>	540kg	540kg	900kg	540kg
<b>Gear Ratio:</b>	4.3:1	4.3:1	8.8:1	4.3:1
<b>Hub Diameter:</b>	Ø45mm	Ø45mm	Ø63mm	Ø45mm
<b>Maximum Cable/Webbing Size:</b>	Ø4mm x 10m (cable not included)	Ø4mm x 10m (cable supplied)	Ø6.35mm x 15m (cable supplied)	50mm x 6m (webbing supplied)
<b>Handle Length:</b>	200mm	200mm	250mm	200mm
<b>Weight:</b>	2.9kg	3.7kg	8.6kg	3.7kg



## A ATV1000W

### 12V ATV Winch 1000kg Line Pull - Wireless

Suitable for ATV mounting. 3-Stage planetary gears. 12V DC 1.2hp Permanent magnet motor. Pull and turn clutch. 4-Way roller fairlead for even distribution of cable onto drum. Wireless remote included.

Supply:	12V
Line Pull*:	1000kg/2200lb
Motor Power:	0.9kW/1.25hp
Gear Ratio:	166:1
Line Speed*:	No Load - 3.3m/min, Maximum Load - 0.8m/min
Current Draw:	No-Load - 12A, Maximum Load - 118A
Wire Rope Diameter:	Ø4.8mm
Replacement Wire Rope:	ATV1000W.WR

\*Performance quoted at first layer of cable on drum

## B-C SEE BELOW

### ATV/Quad Recovery Winches

Suitable for ATV and quad bike mounting, these high speed winches offer a combination of performance with durability. Designed and built with the toughest jobs in mind. High power 12V DC motor with permanent magnet gives first class pulling power. Heavy-duty all-weather housing. 3-Stage planetary gears. Patented unique automatic spring brake, reliable in full load operation. Sliding ring gear clutch. High quality wire rope feeds through 4-way roller fairlead. IP67 rated motor and gearbox.

	B	C
Model No:	ATV1135	ATV2040
Voltage:	12V	12V
Line Pull*:	1135kg(2500lb)	2040kg(4500lb)
Motor Power:	1.8kW(2.34hp)	2.5kW(3.25hp)
Gear Ratio:	180:1	180:1
Line Speed*:		
No-Load:	4.8m/min	4.5m/min
Maximum Load:	1.6m/min	1.3m/min
Current Draw:		
No-Load:	26A	30A
Maximum Load:	150A	185A
Wire Rope Diameter:	Ø4.8mm	Ø5.4mm
Wire Rope Length:	14m	17m
Weight:	11.8kg	13.9kg
Replacement Wire Rope:	ATV1135.WR	ATV2040.WR
Dyneema Rope:	ATV1135.DR	ATV2040.DR

\*Performance quoted at first layer of rope on drum

## D UWRC01

### 4-Pin Universal Winch Remote Control

Universal wireless remote control kit has a 4-pin plug-and-play receiver. With a range of up to 30m (dependant on environment), a wireless remote control is an essential accessory. Weatherproof receiver and handset making it ideal for off-roaders and recovery trucks, enabling the operator to stand well clear or sit in the cab (provided there are no restrictions).

Contents:	Handheld Control Unit (x1), 4-Pin Plug-and-Play Receiver Unit (x1)
Range:	30m
Battery:	MN21 23A (supplied)

## E SEE BELOW

### Aluminium Hawse Fairleads

Machined from billet aluminium and for use in conjunction with Dyneema rope. Simply replaces the 4-way fairlead roller used with wire rope and helps protect and extend the life of the rope. Available in four sizes: 124, 152, 254, 280mm between mounting centres.

Model No:	Distance Between Mounting Centres:	Rope Aperture:	Overall Width
AHF124	124mm	19.3 x 81mm	150mm
AHF152	152mm	19.3 x 110mm	178mm
AHF254	254mm	14 x 205mm	299mm
AHF280	280mm	14 x 205mm	325mm

## A NEW

12V



1000W

1000kg

## B

12V

1135kg

1800W



## C

12V

2040kg

2500W



## D



## E

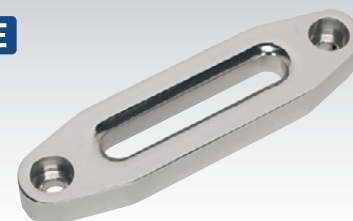

## F



## G



## F SEE SPEC TABLES

### Replacement Wire Rope

All winches are supplied as standard with wire rope. As this is a consumable part, replacement ropes are available (N.B. Hook not included). See winch specification chart for correct model number to suit your winch.

## G SRKIT01

### ATV/Quad Bike Self Recovery Kit

Self recovery kit increases pulling capacity, changes pulling direction and is essential for getting the most out of an ATV/quad bike winch. Supplied in a black heavyweight nylon bag.

Contents:	2000kg Snatch Block (x1), 1400kg Galvanized 'D' Shackles (x2), 2500kg Tree/Post Slings 1.8m x 25mm (x2)
-----------	---

**A**

**12V**  
**4300kg**  
**1900W**



**B**

**12V**  
**5450kg**  
**2000W**



**Premier**

**3 YEAR**  
**GUARANTEE\***

**A-B SEE BELOW**  
**Self Recovery Winches**

The self recovery winch range is designed and built with the toughest jobs in mind. There are two models ranging from 4300kg to 5450kg line pull. Both models have heavy-duty motors, 3-stage planetary gears using oversized components for greater torque, plus automatic 'in drum' brake. They feature weather sealed solenoids and ergonomic 'lift & turn' free spool clutches. Supplied with wire rope, latched hook and 4-way roller fairlead and plug-in handheld controller also included as standard. Suitable for off-road use on 4x4 vehicles and other vehicles where self recovery may be required. IP67 rated.



**C**

**12V**  
**5675kg**  
**4700W**



**D**

**12V**  
**8180kg**  
**2300W**



**Premier**

**3 YEAR**  
**GUARANTEE\***

**C-D SEE BELOW**  
**Industrial Recovery Winches**

The industrial recovery winch range is designed and built for breakdown recovery and off-road use. Two models range from 5675kg to 8180kg line pull. Both have heavy-duty motors with 4-stage planetary gears using oversized components for greater torque, plus automatic 'in drum' brake. Both models have weather sealed solenoids and ergonomic 'lift & turn' free spool clutches. Units supplied with wire rope, latched hook, 4-way roller fairlead and plug-in handheld controller as standard. Ideal for flat bed pick up or other recovery trucks.



	<b>A</b>	<b>B</b>	<b>C</b>	<b>D</b>
<b>Model No:</b>	SRW4300	SRW5450	RW5675	RW8180
<b>Current Draw:</b>				
<b>No-Load:</b>	90A	90A	50A	95A
<b>Maximum Load:</b>	420A	460A	390A	420A
<b>Gear Ratio:</b>	196.6:1	196.6:1	171:1	516:1
<b>Line Pull*:</b>	4300kg(9500lb)	5450kg(12000lb)	5675kg(12500lb)	8180kg(18000lb)
<b>Line Speed*:</b>				
<b>No-Load:</b>	4.3m/min	4.3m/min	15m/min	3.5m/min
<b>Maximum Load:</b>	1.6m/min	0.6m/min	1m/min	0.8m/min
<b>Motor Power:</b>	1.9kW	2kW	4.7kW	2.3kW
<b>Supply:</b>	12V	12V	12V	12V
<b>Wire Rope Length:</b>	26m	26m	26m	25m
<b>Wire Rope Diameter:</b>	Ø9.2mm	Ø9.2mm	Ø9.2mm	Ø13mm
<b>Weight:</b>	40kg	40.5kg	41kg	69kg
<b>Replacement Wire Rope:</b>	SRW5450.WR	SRW5450.WR	RW5675.WR	RW8180.WR
<b>Dyneema Rope:</b>	SRW5450.DR	SRW5450.DR	n/a	n/a

\*Performance quoted at first layer of rope on drum



**A-B**  
**NEW**  
**12V**



**A-B SEE RIGHT**  
**Wireless Winch Combo Kits**

Suitable for ATV and quad bike mounting, these high-speed winches offer a combination of performance teamed with durability and are designed and built with the toughest jobs in mind. These models feature a powerful 12V DC motor with permanent magnet, that gives first class pulling power. Features heavy-duty all-weather housing and 3-stage planetary gears. Patented unique automatic spring brake, reliable in full load operation and sliding ring gear clutch. High quality wire rope feeds through 4-way roller fairlead. IP67 rated motor and gearbox. See page 1364 for full specification.

Model No:	Line Pull*:
<b>A</b> ATV1135KIT	1135kg(2500lb)
<b>B</b> ATV2040KIT	2040kg(4500lb)

**Contents:** ATV1135 or ATV2040 - 12V Self-Recovery Winch, UWRC01 - 4-Pin Universal Winch Remote Control  
\*Performance quoted at first layer of rope on drum

**C**  
**NEW**  
**12V**  
**8180kg**  
**2300W**



**D**  
**NEW**  
**12V**



**5675kg**  
**4700W**

**C RW8180KIT**  
**RW8180 Wireless Winch Combo Kit**

**Premier** **3 YEAR GUARANTEE\***

This industrial recovery winch is designed and built for breakdown recovery and off-road use. Features 12V DC heavy-duty motor with 4-stage planetary gears, using oversized components for greater torque, plus an automatic 'in drum' brake. Winch has weather sealed solenoids and ergonomic 'lift & turn' free spool clutch. Supplied with wire rope, latched hook, 4-way roller fairlead for smooth and even distribution of cable onto drum and plug-in handheld controller as standard. Ideal for flatbed pick-up or other recovery trucks. See pages 1364 and 1365 for full specification.

**Contents:** RW8180 - 12V Industrial Recovery Winch 8180kg(18000lb) Line Pull, UWRC01 - 4-Pin Universal Winch Remote Control

**D RW5675KIT**  
**RW5675 Wireless Winch Combo Kit**

**Premier** **3 YEAR GUARANTEE\***

Designed and built for breakdown recovery and off-road use. Features a heavy-duty motor with 4-stage planetary gears using oversized components for greater torque, plus automatic 'in drum' brake. Weather sealed solenoids and ergonomic 'lift & turn' free spool clutches. Supplied with wire rope, latched hook, 4-way roller fairlead and plug-in handheld controller as standard. Ideal for flatbed pick up or other recovery trucks. See pages 1364 and 1365 for full specification.

**Contents:** RW5675 - 12V Industrial Recovery Winch 5675kg(12500lb) Line Pull, UWRC01 - 4-Pin Universal Winch Remote Control.

**E-F**  
**NEW**  
**12V**



See winch spec table on page 1365 for Dyneema rope

**E-F SEE RIGHT**  
**Self-Recovery Wireless Winch Combo Kits**

The self-recovery winch range is designed and built with the toughest jobs in mind. There are two models ranging from 4300kg to 5450kg line pull. Both models have heavy-duty motors, 3-stage planetary gears using oversized components for greater torque, plus automatic 'in drum' brake. They feature weather sealed solenoids and ergonomic 'lift & turn' free spool clutches. Supplied with wire rope, latched hook and 4-way roller fairlead and plug-in handheld controller also included as standard. Suitable for off-road use on 4x4 vehicles and other vehicles where self-recovery may be required. IP67 rated. See pages 1364 and 1365 for full specification.

**Premier** **3 YEAR GUARANTEE\***

Model No:	Line Pull:
<b>E</b> SRW4300KIT	4300kg(9500lb)
<b>F</b> SRW5450KIT	5450kg(12000lb)

**Contents:** SRW4300 or SRW5450 - 12V Self-Recovery Winch, UWRC01 - 4-Pin Universal Winch Remote Control. Dyneema Rope is offered as an alternative upgrade option for Model No's SRW4300 and SRW5450, see page 1365.





**A TH2002**  
**Tow Rope 2000kg Rolling Load Capacity**

Heavy-duty non-elastic tow rope with a maximum rolling load of 2 Tonne. The rope is 4m in length and is fitted with easy fit metal clips.

<b>Maximum Rolling Load Capacity:</b>	2 Tonne
<b>Length:</b>	4m



**B-C SEE BELOW**

**Tow Ropes**

Elasticated webbing design helps prevent tow rope dragging on the ground during overrun. Ropes feature tough, heavy-duty stitched hook retaining sleeves. Exhaustively tested for compliance with HSE requirements.

<b>B Model No:</b>	TH2502
<b>Maximum Rolling Load Capacity:</b>	2 Tonne
<b>C Model No:</b>	TH3002
<b>Maximum Rolling Load Capacity:</b>	3 Tonne



**E TPK2522**  
**Tow Pole with Shock Spring 2000kg Rolling Load Capacity**

2 Tonne Rolling load capacity tow pole with spring loaded damper unit. Locking tow hook attachment ensures secure attachment to vehicle. Suitable for mixed towing hook configurations, i.e. not both horizontal or vertical. Supplied in pouch.

<b>Maximum Rolling Load Capacity:</b>	2 Tonne
<b>Length:</b>	1.8m

**F TPK253**  
**Tow Pole 2500kg Rolling Load Capacity**

2.5 Tonne Rolling load capacity rigid tow pole. Hook mechanism allows for mounting pole between vehicles where towing eyes may be mixed, i.e. not both horizontal or vertical.

<b>Maximum Rolling Load Capacity:</b>	2.5 Tonne
<b>Length:</b>	1.8m



**D TH5002**  
**Tow Rope 5000kg Rolling Load Capacity**

Elasticated webbing design helps prevent tow rope dragging on the ground during overrun. Ropes feature tough, heavy-duty stitched hook retaining sleeves. Exhaustively tested for compliance with HSE requirements.

<b>Maximum Rolling Load Capacity:</b>	5 Tonne
---------------------------------------	---------

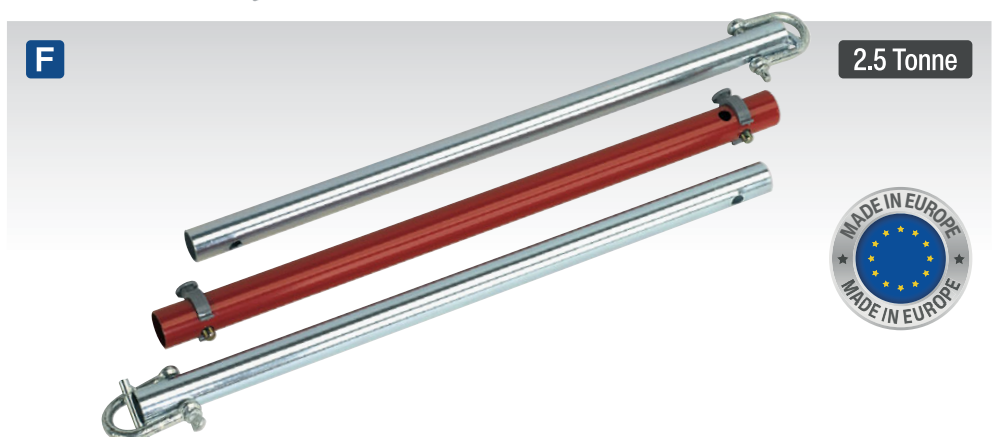
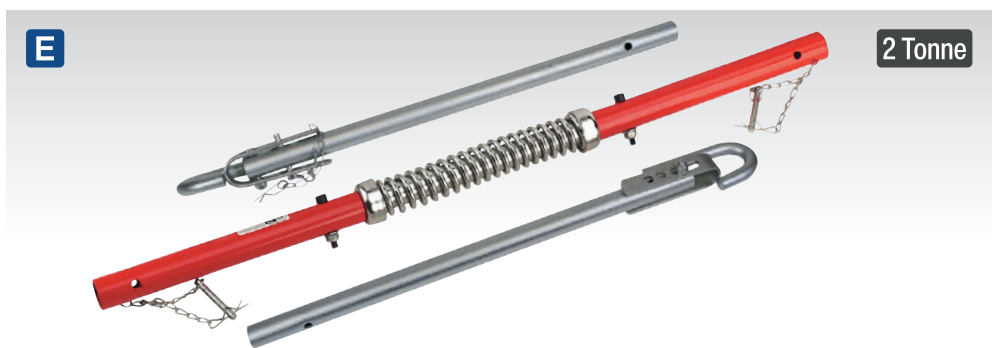

**IMPORTANT**  
 Tow ropes are designed to pull rolling loads only. Do not use for lifting or hoisting. Before use, check tow rope for signs of wear or damage and always consult the vehicle's manual for towing guidelines. Also ensure your insurance covers towing.



**A** 2200kg Capacity



Tandem loading rollers with sealed-for-life bearings all round.

**A PT2200**  
**1150 x 525mm Pallet Truck - 2200kg Capacity**

Heavy-duty truck suitable for warehouse and general handling duties. Polyurethane, non-marking wheels and tandem loading rollers with sealed-for-life bearings all round. Robust and durable galvanized hydraulic unit with chromed ram and piston for resistance to corrosion.

Capacity:	2200kg
Minimum Height:	85mm
Maximum Height:	200mm
Forks (Length x Overall Width):	1150 x 525mm
Fork Spread:	225mm



**C**

3000kg Capacity  
**HEAVY DUTY**

**75+ KG**  
**HEAVY ITEM**

**C APR3001**  
**Heavy-Duty Racking Unit 3 Beam Set - 1000kg Capacity/Level**

Racking unit with upright frames and cross beams. 1000kg Capacity per level. Designed for direct loading of small storage pallets.

Beam Width:	2250mm
Overall Size (W x D x H):	2250 x 1000 x 2000mm
Capacity:	3000kg (1000kg per level)

**E PTS1**  
**Pallet Truck Stop**

Manufactured from non-slip durable rubber. Designed to secure pallet truck wheels to eliminate freight and vehicle damage due to unsecured pallet trucks while in transit. Ideal for delivery companies and other material handling applications.

Size (W x D x H):	300 x 360 x 47mm
Weight:	1.74kg



**B**  
 1000kg Capacity  
**HIGH LIFT**

**75+ KG**  
**HEAVY ITEM**



**B PT1170H**  
**1170 x 540mm High Lift Pallet Truck - 1000kg Capacity**

Heavy-duty high lift pallet truck suitable for the loading/unloading of light commercial vehicles as well as warehouse/general handling duties. Features twin stabilisers for extra balance when at maximum lift and an ergonomic handle design for comfortable operation.

Capacity:	1000kg
Minimum Height:	85mm
Maximum Height:	800mm
Forks (Length x Overall Width):	1170 x 540mm
Fork Spread:	225mm

**D**  
 2000kg Capacity



**75+ KG**  
**HEAVY ITEM**



**D PT1150SC**  
**1150 x 555mm Pallet Truck with Scales - 2000kg Capacity**

Heavy-duty pallet truck suitable for warehouse and general handling duties. Features built-in weighing scales with an accuracy of +/-1kg. 6-Digit, high contrast LCD display. Control panel has a tare function to allow for packaging weight. Scales powered by a built in 6V/4.5A rechargeable battery. Supplied with charging level indicator pin charger.

Capacity:	2000kg
Minimum Height:	85mm
Maximum Height:	200mm
Forks (Length x Overall Width):	1150 x 555mm
Fork Spread:	115mm
Display:	6-Digit LCD
Battery:	6V/4.5A Lead Battery

**A**

**150kg Capacity**

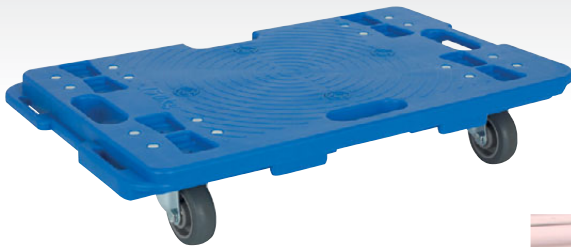

Sold as singles.



Can be linked to create the required platform.

**A CM150**

**150kg Interlocking Plastic Dolly**

Interlocking plastic dollies can be linked lengthways or sideways to allow the user to create the platform they need to move large or heavy items around the workplace with ease. Each dolly can hold up to 150kg of evenly spread weight. Injection mould plastic features non-slip pads which prevent load from slipping. The design of the dolly also allows for these to be stacked safely on top of each other (maximum 10 high) when not in use. They also feature built-in carry handles to aid transportation and 75mm TPR double ball-bearing castors for manoeuvrability.

**B**

**150kg Capacity**



**B CM4**

**Set of 4 Corner Transport Dollies - 150kg Capacity**

Heavy-duty corner dollies manufactured from high quality steel with a maximum load weight of 150kg. Ideal for moving awkward rectangular loads and provides increased mobility in locations where normal material handling equipment cannot be used. Each corner dolly is fitted with three free moving castor wheels for easy manoeuvrability and fitted with a rubber covered load area to help secure loads. Ideal for moving items such as cabinets, desks and much more. Sold in sets of four.

**C**

**Aluminium**

**70kg Capacity**



**C ST33**

**70kg Compact Folding Aluminium Sack Truck**

Lightweight aluminium and composite construction, weighs just 3.8kg. Fitted with heavy duty solid rubber tyres, which cannot be punctured by sharp objects. Wheels are also resistant to most oils, grease and many common chemicals, perfect for work on building site. Folds down for easy storage and transport, yet unfolds in seconds, carrying up to 70kg. Rubber grip handle for added comfort and control.

<b>Folded Size:</b>	480 x 65 x 720mm
<b>Unfolded Size:</b>	480 x 420 x 990mm
<b>Wheel Size:</b>	Ø175mm

**D**

**Aluminium**

**90kg Capacity**



**D CST980**

**90kg Folding Sack Truck**

Lightweight aluminium frame, weighs only 7kg yet has a carrying capacity of 90kg. Folding steel foot plate and telescopic handle with spring release means that trolley can be packed away in seconds. Large back support makes light work of oversized loads. Fitted with Ø150mm wheels for easy-rolling over rough ground. Ideal for business and home use.

<b>Height Folded:</b>	720mm
<b>Height Extended:</b>	1090mm
<b>Width:</b>	380mm
<b>Footplate Width:</b>	355mm
<b>Footplate Depth:</b>	240mm
<b>Wheel Size:</b>	Ø150mm



## A CST983

### 150kg Sack Truck with Solid Tyres

Strong tubular steel construction with welded joints. Heavy-duty wheels feature steel inserts for added strength and durability. Can be rested on handles for flat loading. Fitted with rubber handgrips.

## B-F SEE BELOW

### Sack Trucks with Pneumatic Tyres

Extra-strong tubular steel frame construction. Steel centred pneumatic wheels allow transport over the roughest terrain. Range includes case carrying models, CST988 and CST998, with 'P' handle, high back and flat loading capabilities. Model No's CST986, CST987 & CST999 include handgrips.



	A	B	C
Model No:	CST983	CST986	CST987
Capacity:	150kg	200kg	200kg
Wheel Diameter:	Ø210mm	Ø250mm	Ø250mm
Wheel Thickness:	50mm	90mm	90mm
Height:	1170mm	1100mm	1190mm
Overall Width:	460mm	550mm	545mm
Platform Depth:	220mm	180mm	255mm

	D	E	F
Model No:	CST988	CST999	CST998
Capacity:	250kg	300kg	300kg
Wheel Diameter:	Ø250mm	Ø250mm	Ø250mm
Wheel Thickness:	90mm	90mm	90mm
Height:	1260mm	1300mm	1300mm
Overall Width:	560mm	500mm	550mm
Platform Depth:	220mm	280mm	230mm



CST988, CST998 & CST999 design enables flat loading.

Model No's. CST988 and CST998 feature 'P' handle design which enables one-hand control leaving the other free to open doors etc.



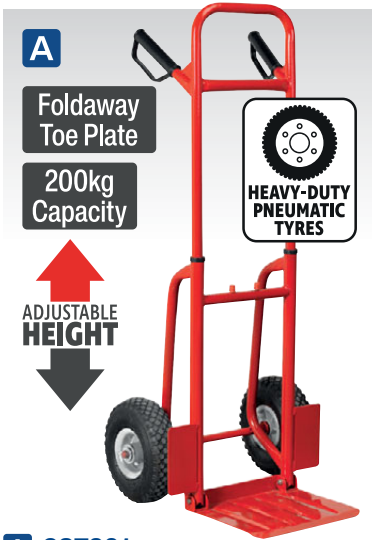

**A**

Foldaway  
Toe Plate

200kg  
Capacity



HEAVY-DUTY  
PNEUMATIC  
TYRES

**A CST801**  
**200kg Folding Sack Truck with Pneumatic Tyres**

Extra-strong tubular steel framework with heavy-duty pneumatic tyres allow transport of load over rough terrain. Features foldaway toe plate and height-adjustable handles. Fitted with composite grip handles for added comfort and stability.

Wheel Diameter:	Ø250mm
Wheel Thickness:	80mm
Overall Width:	480mm
Platform Depth:	290mm
Handle Height Extended:	1165mm
Handle Height Non- Extended:	810mm



**B**

Foldaway  
Toe Plate

150kg  
Capacity



HEAVY-DUTY  
PNEUMATIC  
TYRES

**B CST800**  
**150kg Folding Sack Truck with Pneumatic Tyres**

Manufactured from extra-strong tubular steel with heavy-duty pneumatic tyres for transportation over rough terrain. Features foldaway toe plate providing increased loading area. Ideal for delivery drivers, farmers or builders.

Wheel Diameter:	Ø250mm
Wheel Thickness:	90mm
Height:	1140mm
Overall Width:	490mm
Platform Depth Standard/Extended:	90/420mm



**C**

Foldaway  
Toe Plate

250kg  
Capacity



HEAVY-DUTY  
PNEUMATIC  
TYRES

**C CST990**  
**250kg Folding Sack Truck with Pneumatic Tyres**

Extra-strong tubular steel frame construction. Galvanized steel centred pneumatic wheels allow transport over the roughest terrain. Features extra foldaway toe plate for added extension when transporting larger loads. Ideal for delivery drivers, farmers or builders.

Wheel Diameter:	Ø250mm
Wheel Thickness:	90mm
Height:	1249mm
Overall Width:	650mm
Platform Depth Standard/Extended:	325/620mm



**B**



**D**

150kg  
Capacity

Solid  
Tyres



**D CST985**  
**150kg Stair Climbing Sack Truck with Solid Tyres**

Tubular steel construction gives 150kg maximum load capacity. Deep foot ensures cartons stay on trolley during transit. Fitted with solid rubber wheels. Handle design allows a firm grip whilst ascending and descending stairways. Ideal for delivery drivers and couriers.

Wheel Diameter:	Ø165mm
Wheel Thickness:	30mm
Height:	1300mm
Overall Width:	510mm
Platform Depth:	230mm



**E**

Foldaway  
Toe Plate

250kg  
Capacity

3-in-1



HEAVY-DUTY  
PNEUMATIC  
TYRES

**E CST989**  
**250kg 3-in-1 Sack Truck with Pneumatic Tyres**

Tubular steel framework with heavy-duty pneumatic tyres allows transport of load over rough terrain. Suitable for use as a traditional sack truck or at 45° with support castors in position. For maximum load carrying capability use in horizontal position. Features fold out load restrainer for use when truck is in horizontal position. Adapts between configurations in seconds.

Wheel Diameter:	Ø250mm
Wheel Thickness:	90mm
Height:	1275mm
Overall Width:	600mm
Platform Depth:	300/620mm



**E**



**A** **Premier**

200kg Capacity

HEAVY-DUTY PNEUMATIC TYRES

3 YEAR GUARANTEE\*



**B** **Premier**

250kg Capacity

HEAVY-DUTY PNEUMATIC TYRES

3 YEAR GUARANTEE\*



**C** **Premier**

250kg Capacity

HEAVY-DUTY PNEUMATIC TYRES

3 YEAR GUARANTEE\*



**A-C SEE BELOW**

**Heavy-Duty Sack Trucks with PU Tyres**

Heavy-duty tubular steel construction with welded joints with an extra 50kg capacity to the standard models. Puncture proof heavy-duty PU tyres with powder coated steel hubs and fitted with knuckle protecting D-shaped handle grips.

	<b>A</b>	<b>B</b>	<b>C</b>
Model No:	CST983HD	CST986HD	CST987HD
Capacity:	200kg	250kg	250kg
Wheel Size:	Ø210mm	Ø250mm	Ø250mm
Wheel Width:	55mm	85mm	85mm
Wheel Bore Size:	Ø16mm	Ø16mm	Ø16mm
Height:	1150mm	1150mm	1220mm
Overall Width:	470mm	525mm	540mm
Platform Depth:	220mm	180mm	250mm



**PUNCTURE PROOF TYRES**

Filled with hard wearing PU (Polyurethane) these tyres provide the best features of both maintenance-free solid wheels and the smooth, shock absorbing properties of rubber wheels.

**D** 300kg Capacity Foldaway Toe Plate 3 YEAR GUARANTEE\* **Premier**

HEAVY-DUTY PNEUMATIC TYRES

HEAVY DUTY



**D CST989HD**

**300kg Heavy-Duty 3-in-1 Sack Truck with PU Tyres**

Heavy-duty tubular steel construction with welded joints with 300kg capacity. Puncture proof heavy-duty PU tyres with powder coated steel hubs. Features foldaway toe plate for added extension when transporting larger loads. Can be used as a traditional sack truck or at a 45° angle with support castors.

Wheel Size:	Ø250mm
Wheel Width:	85mm
Wheel Bore Size:	Ø20mm
Height:	1220mm
Overall Width:	600mm
Platform Depth:	Fixed; 300mm, Folding; 600mm

**E** 300kg Capacity Foldaway Toe Plate 3 YEAR GUARANTEE\* **Premier**

HEAVY-DUTY PNEUMATIC TYRES

HEAVY DUTY



**E CST990HD**

**300kg Heavy-Duty Sack Truck with PU Tyres**

Heavy-duty tubular steel construction with welded joints with 300kg capacity. Puncture proof heavy-duty PU tyres with powder coated steel hubs. Features foldaway toe plate for added extension when transporting larger loads.

Wheel Size:	Ø250mm
Wheel Width:	85mm
Wheel Bore Size:	Ø20mm
Height:	1220mm
Overall Width:	580mm
Platform Depth:	Fixed; 300mm, Folding; 600mm



**A**

**70kg Capacity**

**A CST802**  
**Folding Canvas Trolley**

Medium duty tubular steel frame with red canvas material. Collapsible frame for easy storage. Suitable for a wide variety of warehouse, office, garden and domestic hauling applications. Maximum capacity of 70kg. Folded Dimensions (L x W x H): 800 x 535 x 200mm.

Capacity:	70kg
Wheel Size:	Ø200 x 45mm
Platform Height:	280mm, Height to Top of Canvas; 535mm
Platform Length:	900mm
Platform Width:	535mm
Overall Height:	1180mm (inc. handle)



**D**

**300kg Capacity**

**D CST773**  
**Platform Truck with Removable Sides**

Welded construction with 15mm wood composite platform and four removable wire mesh panels. Two fixed wheels and two braked castors for easy manoeuvring and safe loading/unloading. Ideal for warehouse and industrial applications.

Capacity:	300kg
Wheel Size:	Ø200 x 50mm
Platform Size (L x W):	1200 x 800mm
Platform Height:	280mm
Side Height:	590mm
Overall Width:	800mm
Overall Length:	1420mm
Overall Height:	1150mm



**B**

**200kg Capacity**



**B CST997**  
**Platform Truck with Folding/Removable Sides**

Heavy-duty steel with hinged mesh construction. Cushioned grip pull handle with smooth steering action for easy manoeuvrability. Steel centred pneumatic wheels allow transport over the toughest terrain. Drop-down sides, for easy loading, are also removable, allowing use as a flatbed for oversized items. Suitable for a variety of warehouse, office, garden and domestic hauling applications.

Capacity:	200kg
Wheel Size:	Ø250 x 90mm
Platform Height:	350mm
Cart Size (Internal W x D x L):	480 x 220 x 930mm
Overall Height:	570mm



**C**

**450kg Capacity**



**C CST806**  
**Platform Truck with Folding/Removable Sides**

Heavy-duty rust resistant steel construction. Smooth steering action for easy manoeuvrability, with soft rubber gripped handle and pneumatic wheels for easy transportation over the toughest terrain. All four sides drop-down using locking pin function for easy loading. Can also be used as a flatbed for transporting oversized items. Fitted with additional removable storage tray for carrying smaller items. Suitable for a variety of warehouse, office, garden and domestic applications.

Capacity:	450kg
Wheel Size:	Ø300 x 90mm
Platform Height:	390mm
Cart Size (Internal W x D x L):	560 x 300 x 1120mm
Overall Height:	650mm



**E**

**150kg Capacity**

**F**

**300kg Capacity**

**E-F SEE BELOW**  
**Folding Platform Trucks**

Rigid platform trucks feature rubberised deck and bumper strip. Handles fold flat for ease of storage. Suitable for a variety of warehouse, office and domestic applications.

	<b>E</b>	<b>F</b>
Model No:	<b>CST991</b>	<b>CST992</b>
Capacity:	150kg	300kg
Wheel Diameter:	Ø100mm	Ø125mm
Platform (W x D):	465 x 725mm	605 x 910mm
Platform Height:	140mm	185mm
Overall Height:	815mm	870mm



**G**

**250kg Capacity**

**G CST993**  
**Platform Truck**

Rigid platform truck featuring heavy-duty wooden deck and tubular steel bumper. Fitted with a fully detachable handle for ease of storage. Suitable for a variety of warehouse, office and domestic applications.

Capacity:	250kg
Wheel Diameter:	Ø125mm
Platform (W x D):	495 x 950mm
Platform Height:	225mm
Overall Height:	960mm



**A-D SEE RIGHT**

**Hydraulic Platform Trucks**

Heavy-duty construction. All models fitted with four composite wheels, two fixed and two locking castors, for easy-rolling over rough workshop and warehouse floors. One-piece hydraulic unit controlled by large rear mounted foot pedal. Safety release mechanism positioned on handlebar for smooth controlled descent. All except Model No. HPT500 feature safety bars to prevent inadvertent lowering. Suitable for numerous garage, industrial and warehouse handling applications. Model No's HPT150 - HPT500 supplied with non-slip platform cover for added load security. May also be used as a mobile service bench.

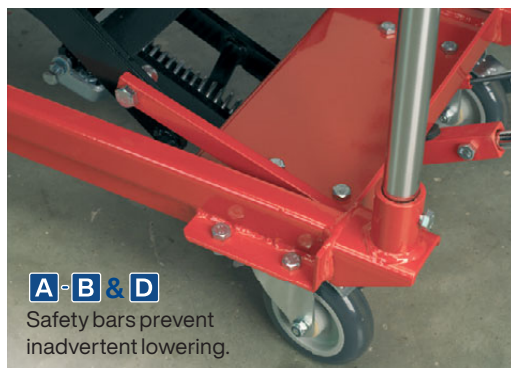

**E HPT400H**

**Hydraulic Platform Truck High Lift 300kg Capacity**

Heavy-duty construction. High lift version with 1290mm maximum platform height. Fitted with four composite wheels, two fixed and two locking castors for easy-rolling over rough workshop and warehouse floors. One-piece hydraulic unit controlled by large rear mounted foot pedal. Safety release mechanism positioned on handlebar for smooth controlled descent. Suitable for numerous garage, industrial and warehouse handling applications. Supplied with non-slip platform cover for added load security. May also be used as a mobile service bench.

<b>Capacity:</b>	300kg
<b>Minimum Platform Height:</b>	360mm
<b>Maximum Platform Height:</b>	1290mm
<b>Platform Length:</b>	910mm
<b>Platform Width:</b>	500mm
<b>Wheel Diameter:</b>	Ø125mm



**F PAR01**

**Portable Access Ramp - 450kg Capacity**

Lightweight, durable access ramp. Ideal for transporting goods up kerbs and steps. Fitted with two carry handles and rubber stoppers to prevent movement while in use. Features 600mm wide textured ramp surface providing additional grip. Maximum capacity 450kg.

<b>Size (W x D x H):</b>	680 x 680 x 120mm
--------------------------	-------------------

	<b>A</b>	<b>B</b>	<b>C</b>	<b>D</b>
<b>Model No:</b>	HPT150	HPT300	HPT500	HPT1000
<b>Capacity:</b>	150kg	300kg	500kg	1000kg
<b>Minimum Platform Height:</b>	225mm	270mm	280mm	430mm
<b>Maximum Platform Height:</b>	700mm	770mm	860mm	1020mm
<b>Platform Length:</b>	705mm	820mm	815mm	1015mm
<b>Platform Width:</b>	450mm	520mm	500mm	510mm
<b>Wheel Diameter:</b>	Ø100mm	Ø125mm	Ø125mm	Ø150mm

**A-D SEE BELOW**

**Flat Bungee Cord Sets**

Sets of two extra-strong bungee cords ideal for multiple applications including garage, workshop, trailer and domestic use. Heavy-duty steel hooks with nylon coating, polypropylene braid with high grade rubber cord giving maximum elasticity. Up to three times stronger than traditional bungee cords.

Model No:	Free Length:	Maximum Stretch:
<b>A</b> BCS15	460mm	1040mm
<b>B</b> BCS16	610mm	1300mm
<b>C</b> BCS17	760mm	2000mm
<b>D</b> BCS18	910mm	2200mm

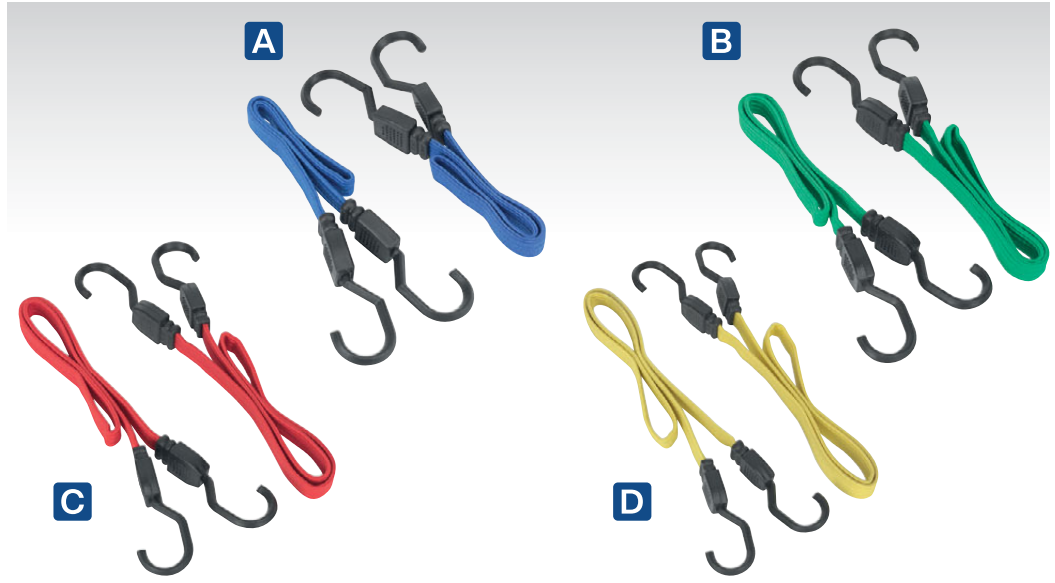

**E-G SEE BELOW**

**Bungee Cord Sets**

Sets of two strong steel hooks with smooth nylon coating to prevent scratching. Heavy-duty polypropylene braid and high grade rubber cord providing maximum elasticity. Ideal for a wide range of applications including garages, workshops and trailers.

Model No:	Free Length:	Maximum Stretch:
<b>E</b> BCS19	460mm	1100mm
<b>F</b> BCS21	610mm	1350mm
<b>G</b> BCS22	760mm	1700mm

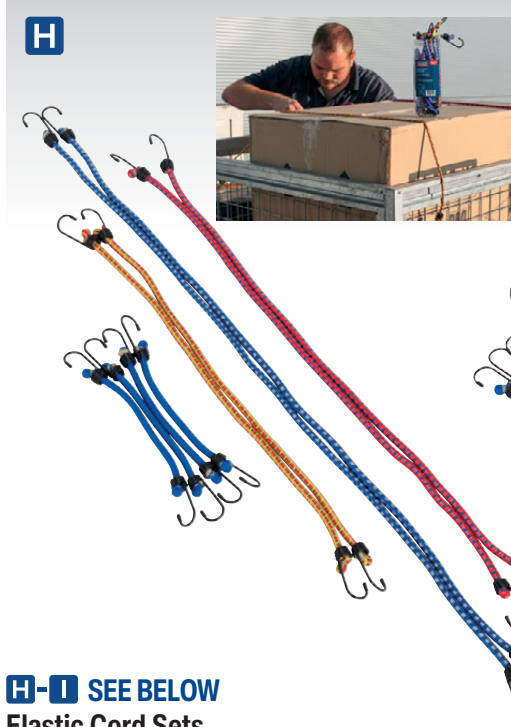
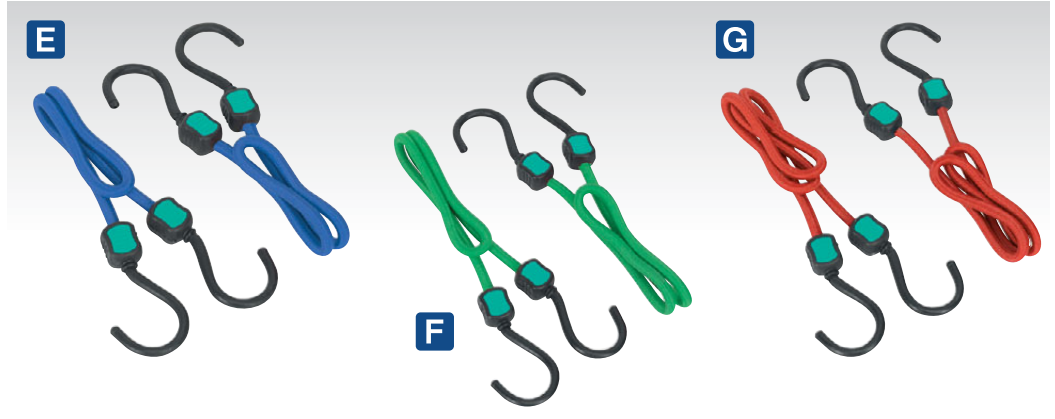

**H-I SEE BELOW**

**Elastic Cord Sets**

Elastic cords make tying items down quick and easy. Can be used in the workshop, garage, car, trailer and caravan. Not suitable for supporting loads. Packaged in a round plastic tube.

Model No:	BCS10	BCS20
<b>Contents:</b>	Ø8 x 250mm (x4), Ø8 x 600mm (x2), Ø8 x 800mm (x2), Ø8 x 1000mm (x2)	Ø8 x 250mm (x4), Ø8 x 400mm (x4), Ø8 x 500mm (x4), Ø8 x 600mm (x4), Ø8 x 750mm (x4)

**J BCS23**

**1000mm Octopus Bungee Cord**

Fitted with eight nylon coated steel hooks to provide a strong hold and prevent scratching. Arms stretch out from centre ring to secure multiple points. Ideal for securing awkward items on trailers and roof racks while in transit.

<b>Free Length:</b>	1000mm
<b>Maximum Stretch:</b>	1800mm



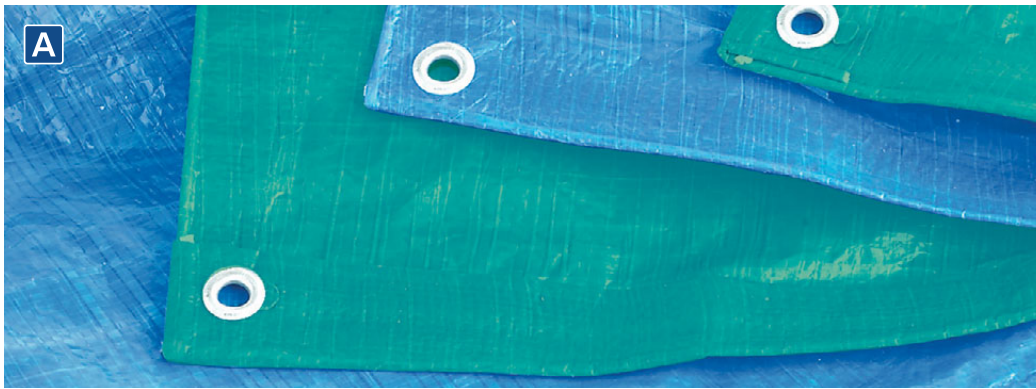

**A TARP68 Tarpaulins**

Manufactured from 130g/m<sup>2</sup> polyethylene with heavy, 30micron laminate. Tear-proof, waterproof and treated with a UV filter to prolong life and durability. Mould and mildew proofed. Constructed with roped edges and metal grommets in all corners and every metre. Top quality tarpaulins available in blue or green are suitable for farm, garden, bodyshop, garage, boat yard and leisure use.

BLUE	GREEN	
<b>Model No:</b>	<b>Model No:</b>	<b>Size:</b>
TARP68	TARP68G	1.73 x 2.13m
TARP810	TARP810G	2.44 x 3.05m
TARP1012	TARP1012G	3.05 x 3.66m
TARP1216	TARP1216G	3.66 x 4.88m
TARP1620	TARP1620G	4.88 x 6.10m
TARP1824	TARP1824G	5.49 x 7.32m
TARP2040	TARP2040G	6.10 x 12.19m

Note: Nominal sizes

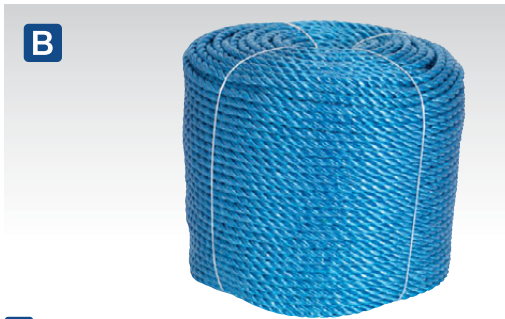

**B SEE BELOW Polypropylene Rope**

Multipurpose heavy-duty weather resistant polypropylene rope. Available in Ø8mm and Ø10mm, in 220m lengths.

Model No:	Diameter:	Length:
RC08220	Ø8mm	220m
RC10220	Ø10mm	220m



**C TARP12 12pc Assorted Tarpaulin Cord Set**

Adjustable composite hooks with ball-ended bungee cords. The cord is detached from the hook, fed through the tarpaulin rope eye and then reattached at the required length. Three different length cords are supplied, with a maximum safe stretch up to 1050mm and safe load up to 20kg.

<b>Contents:</b>	310mm (x4), 440mm (x4), 600mm (x4)
<b>Free Length:</b>	<b>Maximum Stretch:</b>
310mm:	550mm
440mm:	800mm
600mm:	1050mm



**D TARP4 4pc Tarpaulin Clip Set**

Composite clip set with heavy-duty spring. Simple-to-use with tension adjusting control to enable a firm grip of tarpaulins and sheeting without the need to use rope eyes. Suitable for use on trucks, trailers, farm, garden and garage applications.



600kg  
5m  
25mm



**E-F SEE BELOW 25mm x 5m Ratchet Straps**

Manufactured from polyester webbing. Simple drum and ratchet mechanism tensions the webbing to provide superior load restraint. Packaged on a corner protector to allow for immediate use without having to worry about damaged goods.

	<b>E</b>	<b>F</b>
<b>Model No:</b>	TD0635S	TD0635E
<b>Breaking Strain:</b>	600kg	600kg
<b>Maximum Tension:</b>	300kg	300kg
<b>Hook:</b>	S-Type	n/a



**G TD285SBD 6pc Ratchet Strap & Flat Bungee Cord Set**

Manufactured from polyester webbing with stitched reinforcement around hooks. Suitable for securing loads and tarpaulins onto flat-beds or trailers and for general load restraint. Simple drum and ratchet mechanism tensions the webbing to provide superior load restraint. Also includes two 760mm flat bungee cords and a set of two 460mm flat bungee cords.

<b>Contents:</b>	Tie Downs (x2), Bungee Cords (x4)
<b>Maximum Tension:</b>	400kg
<b>Load Test:</b>	800kg
<b>Webbing Width:</b>	25mm
<b>Webbing Length:</b>	5m
<b>Hook:</b>	S-Type

**HOW TO USE RATCHET STRAPS**  
See our video on how to use one piece, two piece and auto retracting ratchet straps.



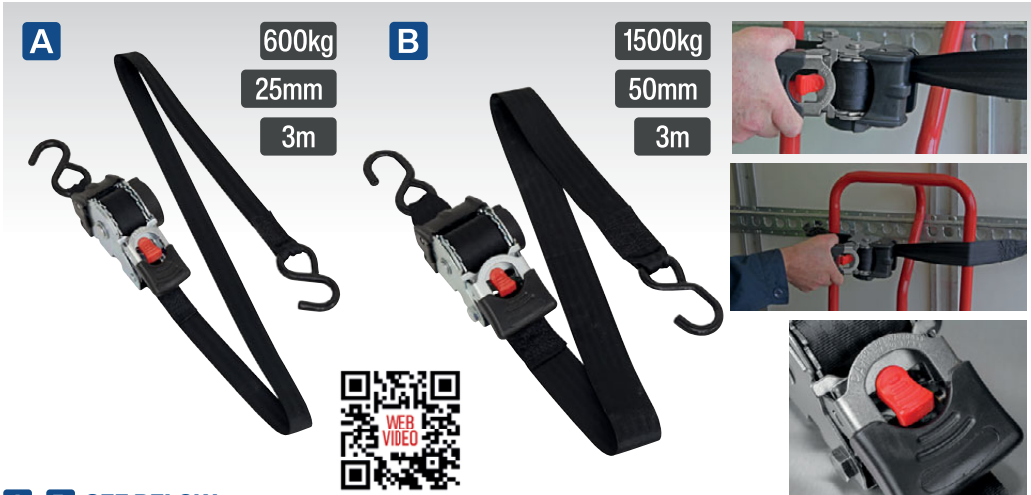

**A-B SEE BELOW**

**Auto Retractable Ratchet Straps**

Manufactured from polyester webbing with stitched reinforcement around hooks. Auto-rewind at a push of a button retracts the webbing, leaving the unit neat and tidy. Simple drum and ratchet mechanism tensions the webbing to provide superior load restraint. Suitable for securing of loads and tarpaulins onto flatbeds or trailers. Handles and release mechanism are rubber coated for added comfort.

	<b>A</b>	<b>B</b>
<b>Model No:</b>	ATD25301	ATD50301
<b>Quantity:</b>	1	1
<b>Maximum Tension:</b>	300kg	750kg
<b>Load Test:</b>	600kg	1500kg
<b>Webbing Width:</b>	25mm	50mm
<b>Webbing Length:</b>	3m	3m
<b>Hook:</b>	S-Type	S-Type



**D-E SEE BELOW**

**Car Transporter Ratchet Straps**

Manufactured from polyester webbing with stitched reinforcement around hooks. Suitable for securing cars on transporters using wheel strap, which slides on to the main strap. Model No. TDRWA features soft wheel choker for use on alloy wheels. A double-locking, short narrow handle ratchet ensures there is no risk of disengagement or tension loss until the handle is released.

	<b>D</b>	<b>E</b>
<b>Model No:</b>	TDRWA	TDRWS
<b>Quantity:</b>	1	1
<b>Maximum Tension:</b>	2500kg	2250kg
<b>Load Test:</b>	5000kg	4500kg
<b>Webbing Width:</b>	50mm	50mm
<b>Webbing Length:</b>	3m	3m
<b>Cross Strap Length:</b>	320mm	320mm
<b>Wheel Type:</b>	Alloy	Steel
<b>Hook:</b>	J-Type	J-Type



**C TD1202SR**

**Slide Ratchet Straps**

Manufactured from polyester webbing with stitched reinforcement around hooks and all fixing points. Suitable for securing heavy loads and tarpaulins onto trailers. Ratchet mechanically tensions the webbing using a simple drum and ratchet mechanism providing superior load restraint. Sliding feature allows mechanism to be located at any point along run of webbing, resulting in reduced load damage and ease of operation. Hook-and-loop straps tidy away excess webbing for improved safety.

<b>Quantity:</b>	2
<b>Maximum Tension:</b>	600kg
<b>Load Test:</b>	1200kg
<b>Webbing Width:</b>	32mm
<b>Webbing Length:</b>	3m
<b>Hook:</b>	S-Type



**F TDRWKIT**

**4pc Car Transporter Ratchet Strap Kit**

Manufactured from polyester webbing with stitched reinforcement around hooks. Suitable for securing cars on transporters using wheel strap, which slides on to the main strap. Includes four ratchet straps, four soft wheel chokers for use on alloy wheels and four wheel chokers with 'O' rings for use on steel wheels. A double-locking, short narrow handle ratchet ensures there is no risk of disengagement or tension loss until the handle is released.

<b>Maximum Tension:</b>	2250kg
<b>Load Test:</b>	4500kg
<b>Webbing Width:</b>	50mm
<b>Webbing Length:</b>	3m
<b>Cross Strap Length:</b>	320mm
<b>Wheel Type:</b>	Alloy or Steel
<b>Hook:</b>	J-Type

**IMPORTANT**

The specification table indicates two load specifications. The maximum tension is that which is developed by the ratchet mechanism. The load test is the capacity of the webbing to resist shock loads.





**A-B SEE BELOW**

**Self-Securing Ratchet Straps**

Manufactured from polyester webbing. These straps are ideal for securing and binding oversized and difficult loads together. Feed webbing around load and back through ratchet mechanism to ensure load is secure. Simple drum and ratchet mechanism tensions the webbing to provide superior load restraint.

	<b>A</b>	<b>B</b>
<b>Model No:</b>	TD05045E	TD08045E
<b>Quantity:</b>	2	2
<b>Maximum Tension:</b>	250kg	400kg
<b>Load Test:</b>	500kg	800kg
<b>Webbing Width:</b>	25mm	25mm
<b>Webbing Length:</b>	4.5m	4.5m

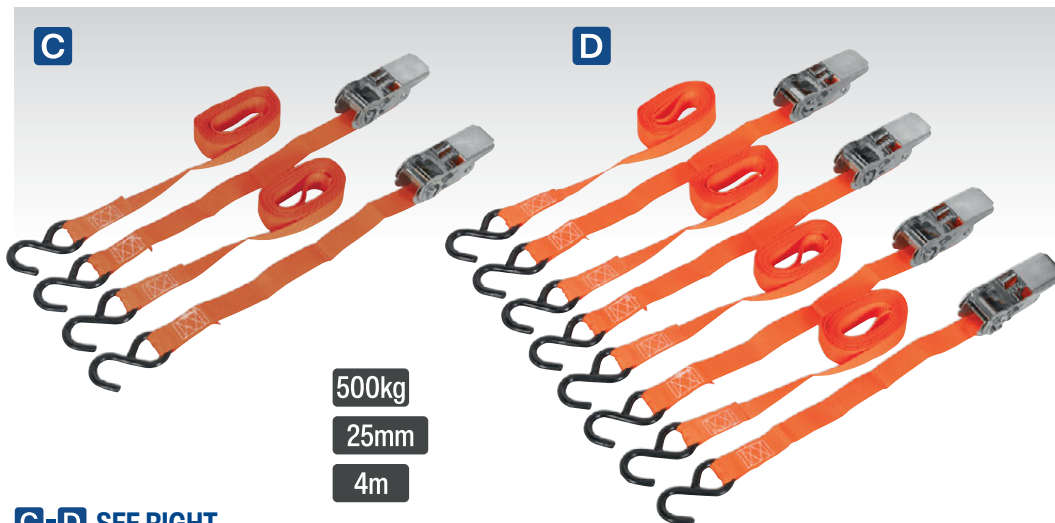

**C-D SEE RIGHT**

**Polyester Webbing Ratchet Straps with S-Hooks**

Manufactured from polyester webbing with stitched reinforcement around hooks. Suitable for securing loads and tarpaulins onto flatbeds or trailers and for general load restraint. Simple drum and ratchet mechanism tensions the webbing to provide superior load restraint.

	<b>C</b>	<b>D</b>
<b>Model No:</b>	TD0540S2	TD0540S4
<b>Quantity:</b>	2	4
<b>Maximum Tension:</b>	250kg	250kg
<b>Load Test:</b>	500kg	500kg
<b>Webbing Width:</b>	25mm	25mm
<b>Webbing Length:</b>	4m	4m
<b>Hook:</b>	S-Type	S-Type



**E-F SEE BELOW**

**Polyester Webbing Ratchet Straps with S-Hooks**

Manufactured from polyester webbing with stitched reinforcement around hooks. Suitable for securing loads and tarpaulins onto flatbeds or trailers and for general load restraint. Simple drum and ratchet mechanism tensions the webbing to provide superior load restraint.

	<b>E</b>	<b>F</b>
<b>Model No:</b>	TD284SD	TD484SD
<b>Quantity:</b>	2	4
<b>Maximum Tension:</b>	400kg	400kg
<b>Load Test:</b>	800kg	800kg
<b>Webbing Width:</b>	25mm	25mm
<b>Webbing Length:</b>	4m	4m
<b>Hook:</b>	S-Type	S-Type

**G-H SEE RIGHT**

**Polyester Webbing Cam Buckle Straps with S-Hooks**

Manufactured from polyester webbing with stitched reinforcement around hooks. Suitable for securing loads and tarpaulins onto flatbeds or trailers and for general load restraint. Simple cam buckle fastener tensions the webbing to provide superior load restraint.

	<b>G</b>	<b>H</b>
<b>Model No:</b>	TD2525CS	TD05025CS
<b>Quantity:</b>	2	2
<b>Maximum Tension:</b>	125kg	250kg
<b>Load Test:</b>	250kg	500kg
<b>Webbing Width:</b>	25mm	25mm
<b>Webbing Length:</b>	2.5m	2.5m
<b>Hook:</b>	S-Type	S-Type



**I TDL01**

**Tie Down Securing Loop - Pair**

Manufactured from polyester webbing. Use to either loop or create a slip knot at any appropriate point of the load and then attach to the hook of the strap. Suitable for use on motorcycles or offset loads to help prevent scratches to paint finishes and chrome.

<b>Maximum Tension:</b>	1000kg
<b>Load Test:</b>	2000kg
<b>Webbing Width:</b>	35mm
<b>Webbing Length:</b>	450mm

**HOW TO USE RATCHET STRAPS**  
See our video on how to use one piece, two piece and auto retracting ratchet straps.



**A-Q SEE BELOW**

**Ratchet Straps**

Manufactured from polyester webbing with stitched reinforcement around hooks. Suitable for securing loads and tarpaulins onto flat-beds or trailers and for general load restraint. Straps rely on the operator tensioning the webbing with body weight. Ratchet mechanically tensions the webbing using a simple drum and ratchet mechanism providing superior load restraint.

	<b>A</b>	<b>B</b>
Model No:	TD0845S	TD0845J
Quantity:	1	1
Maximum Tension:	400kg	400kg
Load Test:	800kg	800kg
Webbing Width:	25mm	25mm
Webbing Length:	4.5m	4.5m
Hook:	S-Type	J-Type



800kg 25mm 4.5m



**HOW TO USE RATCHET STRAPS**  
See our video on how to use one piece, two piece and auto retracting ratchet straps.



6m 8m 10m

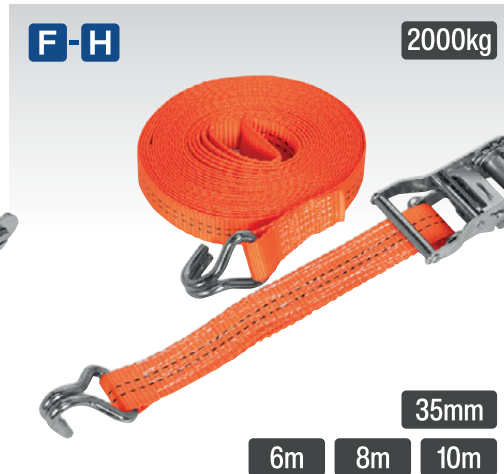

6m 8m 10m



6m 8m 10m

	<b>C</b>	<b>D</b>	<b>E</b>	<b>F</b>	<b>G</b>	<b>H</b>	<b>I</b>	<b>J</b>	<b>K</b>
Model No:	TD1506J	TD1508J	TD1510J	TD2006J	TD2008J	TD2010J	TD3006J	TD3008J	TD3010J
Quantity:	1	1	1	1	1	1	1	1	1
Maximum Tension:	750kg	750kg	750kg	1000kg	1000kg	1000kg	1500kg	1500kg	1500kg
Load Test:	1500kg	1500kg	1500kg	2000kg	2000kg	2000kg	3000kg	3000kg	3000kg
Webbing Width:	25mm	25mm	25mm	35mm	35mm	35mm	50mm	50mm	50mm
Webbing Length:	6m	8m	10m	6m	8m	10m	6m	8m	10m
Hook:	J-Type	J-Type	J-Type	J-Type	J-Type	J-Type	J-Type	J-Type	J-Type



6m 8m 10m



8m 10m 12m



1200kg  
32mm  
4.9m

**R TD41248JD**  
**32mm x 4.9m Polyester Webbing Ratchet Straps with J-Hooks**  
**1200kg Breaking Strength**

Manufactured from polyester webbing with stitched reinforcement around hooks. Suitable for securing loads and tarpaulins onto flatbeds or trailers and for general load restraint. Simple drum and ratchet mechanism tensions the webbing to provide superior load restraint.

	<b>L</b>	<b>M</b>	<b>N</b>	<b>O</b>	<b>P</b>	<b>Q</b>
Model No:	TD5006J	TD5008J	TD5010J	TD10008J	TD10010J	TD10012J
Quantity:	1	1	1	1	1	1
Maximum Tension:	2500kg	2500kg	2500kg	5000kg	5000kg	5000kg
Load Test:	5000kg	5000kg	5000kg	10000kg	10000kg	10000kg
Webbing Width:	50mm	50mm	50mm	75mm	75mm	75mm
Webbing Length:	6m	8m	10m	8m	10m	12m
Hook:	J-Type	J-Type	J-Type	J-Type	J-Type	J-Type

Quantity:	2
Maximum Tension:	600kg
Load Test:	1200kg
Webbing Width:	32mm
Webbing Length:	4.9m
Hook:	J-Type





**IMPORTANT:** These ramps are designed for levelling only. Do **not** work under vehicle whilst it is being supported by these ramps.



**IMPORTANT:** These ramps are designed for levelling only. Do **not** work under vehicle whilst it is being supported by these ramps.

**A WL301**  
**3-Stage Levelling Ramps - 2.5 Tonne Capacity per Ramp**  
**5 Tonne Capacity per Pair**

Ideal for campervans and caravans (capacity 5 Tonne per pair). Not to be used as a lifting ramp for the purpose of working underneath the vehicle. Suitable for single axle vehicles only. Raise wheels to various heights using different points on each ramp, to level vehicle out. Anti roll off step at end of ramp. Durable and easy-to-clean UV resistant high-density polyethylene with a non-slip surface.

**B TS05**  
**Tyre Savers - 2.5 Tonne Capacity per Ramp**  
**5 Tonne Capacity per Pair**

Tyre saving blocks help prevent flat spots or damage to car, caravan or motorhome tyres whilst they are stationary for prolonged periods of time, such as over winter. Maximum weight capacity 5 Tonne per pair. Saves installing winter storage wheels. Increased stability, as wheels cannot easily be moved in either direction without deliberate intent to do so.

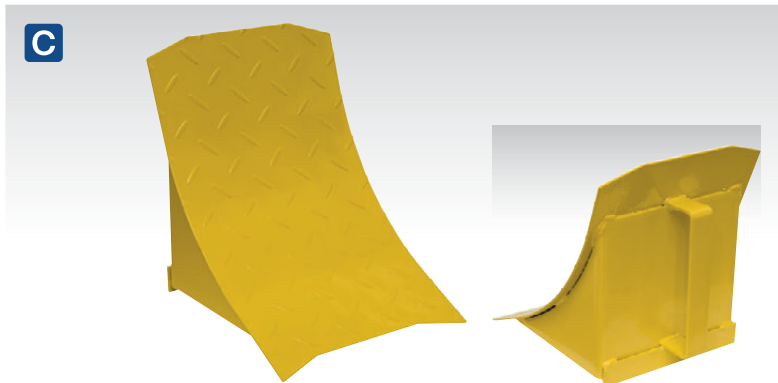

**C WC17**  
**Heavy-Duty Steel Wheel Chock - Single**

Welded steel wheel chock. Prevents vehicle movement when being jacked on a level surface or parked on an incline not exceeding 10°. Suitable for heavy goods vehicles not exceeding 15 Tonne gross weight.

<b>Material:</b>	Steel
<b>Dimensions (W x D x H):</b>	240 x 200 x 230mm
<b>Applications:</b>	Vehicles up to 15 Tonne
<b>Weight:</b>	2.95kg

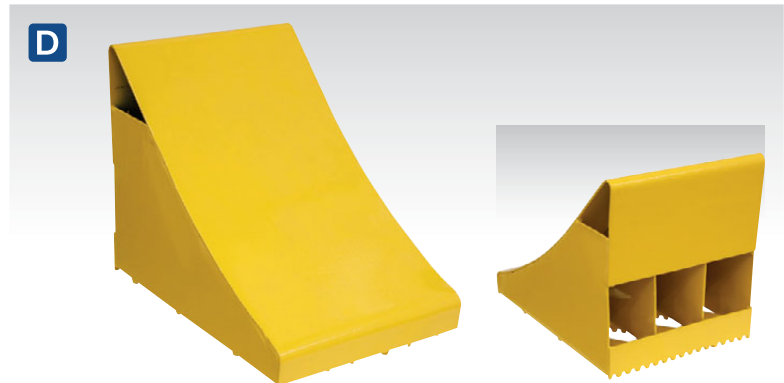

**D WC18**  
**Heavy-Duty Steel Wheel Chock - Single**

Welded steel wheel chock. Prevents vehicle movement when being jacked on a level surface or parked on an incline not exceeding 10°. Suitable for heavy goods vehicles not exceeding 20 Tonne gross weight.

<b>Material:</b>	Steel
<b>Dimensions (W x D x H):</b>	270 x 200 x 245mm
<b>Applications:</b>	Vehicles up to 20 Tonne
<b>Weight:</b>	4.47kg



**E WC02**  
**Rubber Wheel Chocks 3.3kg - Pair**

Two rubber wheel chocks. Prevents vehicle movement when being jacked on a level surface or parked on an incline not exceeding 12°. Suitable for vehicles below 5 Tonne.

<b>Dimensions (W x D x H):</b>	115 x 270 x 175mm
--------------------------------	-------------------



**F WC05**  
**Heavy-Duty Steel Wheel Chocks 4kg - Pair**

Two welded steel wheel chocks. Prevents vehicle movement when being jacked on a level surface or parked on an incline not exceeding 12°. Suitable for heavy goods vehicles.

<b>Dimensions (W x D x H):</b>	200 x 270 x 210mm
--------------------------------	-------------------



**A PB393**  
**Steering Wheel Lock**

Hardened steel lock that is quick and easy to fit to steering wheel. Highly visible deterrent to the vehicle thief. Vinyl coating protects steering wheel from damage. Supplied with two keys.

Wheel Internal Diameter Range: Ø180-365mm



**E PB397**  
**Wheel Clamp with Lock & Key**

Manufactured from quality steel with zinc plating for corrosion resistance. Simple and quick ratchet action makes protection easy. Fully lockable and supplied with two keys. Ideal for forecourt use. Finished in yellow for high visibility.

Minimum Clamp Diameter:	Ø450mm
Maximum Clamp Diameter:	Ø640mm
Maximum Tyre Width:	225mm



**G PB298**  
**3-Legged Parking Barrier with Integral Lock**

Heavy-duty parking barrier manufactured from Ø50mm tube steel. Supplied with integral lock and two keys. Powder coat finish for corrosion resistance. For full security, we suggest you drill out the screw head after installation.

Minimum Height:	60mm
Maximum Height:	450mm
Width:	980mm



**B-C NEW**  
**SEE BELOW**  
**Wall Mounting Convex Mirrors**

Convex mirrors for improved visibility. Supplied with wall fixing and adjustable swivel joint, allowing for quick and easy positioning. Ideal for use as a safety or security mirror.

Model No:	Diameter:
<b>B</b> CM300	Ø300mm
<b>C</b> CM450	Ø450mm

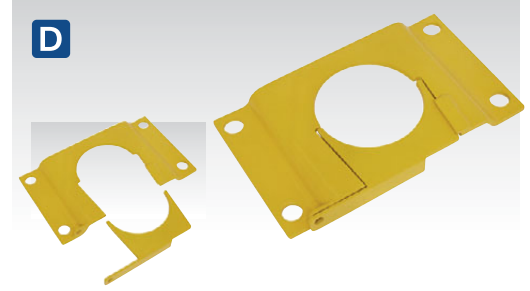

**D RBLP**  
**Removable Bollard Base Plate - Locking**

Steel bollard base plate fixes permanently in place using four pre-drilled Ø23.5mm mounting holes (fixings not included). Base will fit various sizes of bollards (not supplied) - especially suited to Sealey Model No's. BOL600, BOL900, BOL1050 and BOL1200. Ø11mm Padlock hole will accommodate most robust padlock designs.

Minimum Height:	30mm
Width:	340mm
Weight:	3.54kg



**F PB395**  
**Claw Car Wheel Clamp with Lock & Key**

Claw locks around wheel rim and tyre. Simple and quick ratchet action makes fitting easy. Fully lockable. No need to touch wheel or tyre when installing or removing so hands remain clean. Plastic sleeved claws will not damage alloys. Finished in yellow and red for high visibility.

Minimum Clamp Diameter:	Ø180mm
Maximum Clamp Diameter:	Ø270mm
Throat:	190mm



**H STS01**  
**Folding Wheel Step**

Heavy-duty wheel step gives safe and easy-access to engine or top of vehicle, ideal for 4x4s. Heavy gauge all steel construction folds for easy storage. Suitable for wheel diameters between 14" and 20" and will fit tyres up to 10" deep. Rubber topped platform for added grip and safety. Platform is height-adjustable (three mounting points 90mm apart).

Capacity:	225kg
Platform Size:	210 x 560mm
Wheel Diameter:	14"-20"





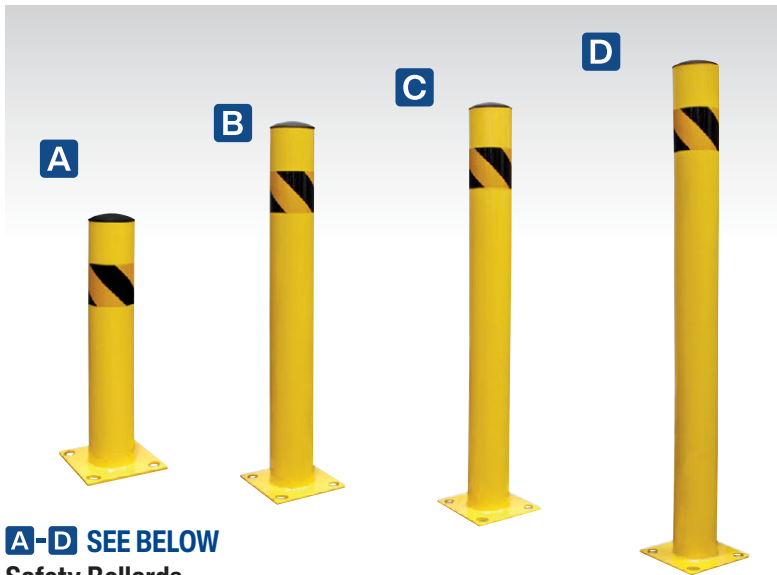

**A-D SEE BELOW**  
Safety Bollards

Constructed from heavy-duty Ø110mm steel pipe. Plastic cap can be removed and the pipe filled with cement for greater impact resistance. 200mm Square base plate has four pre-drilled Ø22mm holes for fixing to floor (fixings not included). Can be installed as a removable bollard with a secure locking collar (requires Model No. RBLP (page 1381) and a padlock, see pages 1070 to 1071).

	<b>A</b>	<b>B</b>	<b>C</b>	<b>D</b>
Model No:	BOL600	BOL900	BOL1050	BOL1200
Height:	600mm	900mm	1050mm	1200mm
Weight:	4.46kg	5.86kg	6.06kg	6.60kg



**E FBOL900**  
900mm Folding Bollard with Lock

Constructed from heavy-duty Ø114 steel pipe. Features integral lock. Sturdy 200 x 220mm base plate with four pre-drilled Ø13.5mm holes for fixing to floor (fixings not included).

Minimum Height:	130mm
Maximum Height:	900mm
Weight:	10.76kg



**F PFB2500**  
2500mm Plastic Folding Barrier

Temporary expanding barriers unfold from 230mm to 2.5m long fully extended. 380mm Wide legs at either end, which can both be filled with water via 20mm screw cap on each one, for greater weighted stability. Each side has red and silver reflective criss-crossing strips for maximum visibility across the whole barrier. Sturdy yet flexible material allows for quick and easy stowing.

Weight:	2.36kg
---------	--------

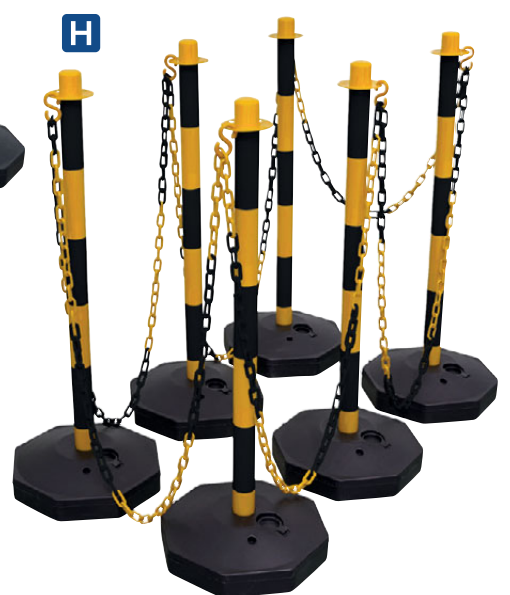
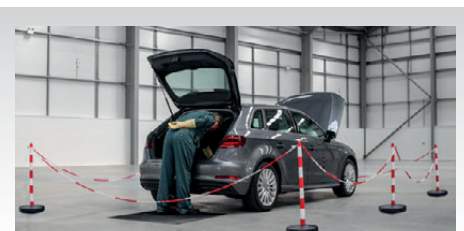

**G-H SEE BELOW**  
Post & Chain Kits

Highly visible post and chain kits ideal for creating a temporary safety barrier when working on hybrid and electric vehicles. Bases can be filled with dry sand for extra stability.

	<b>G</b>	<b>H</b>
Model No:	RWSBKIT	BYSBKIT
Contents:	Six Red/White Posts, Six Bases, 25m x 6mm Red/White Plastic Chain and Chain Securing Hooks	Six Black/Yellow Posts, Six Bases, 25m x 6mm Black/Yellow Plastic Chain and Chain Securing Hooks
Weight:	4.35kg	4.35kg

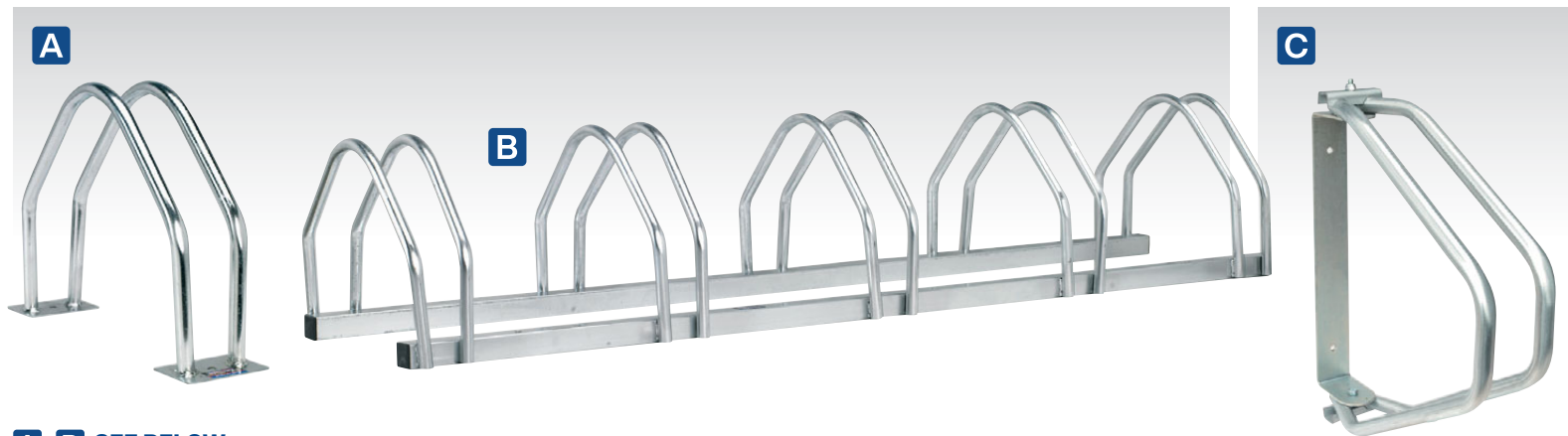

**A-B SEE BELOW**

**Bicycle Racks**

Heavy-duty racks, manufactured from galvanized steel for corrosion resistance.

	<b>A</b>	<b>B</b>
<b>Model No:</b>	<b>BS14</b>	<b>BS16</b>
<b>Bicycle Capacity:</b>	1	5
<b>Dimensions (W x D x H):</b>	90 x 260 x 365mm	1420 x 260 x 320mm
<b>Maximum Tyre Width:</b>	55mm	55mm

**C BS13**

**Adjustable Bicycle Rack Wall Mounting**

Wall mounting bicycle rack. Heavy-duty galvanized steel construction with 180° swivel movement.



**D BS7**

**Folding Bicycle Rack - Wall Mounting**

Wall mounting bicycle rack. Arms fold up when unloaded for compact storage. Supports up to two bicycles (not exceeding 40kg).

<b>Width:</b>	500mm
<b>Arm Length:</b>	490mm
<b>Bicycle Capacity:</b>	2



**E CL9512**

**10mm x 1500mm Motorcycle Chain Lock**

Protective covered chain, avoids accidental scratching and damage to the bike. Triple bearing locking system encased in a double protection body, helps prevent tampering. Supplied with two keys.

<b>Chain Size:</b>	Ø10 x 1500mm
--------------------	--------------



Bicycle can be positioned at various angles.

**ADJUSTABLE HEIGHT**  
**HEAVY DUTY**

Quick release handle.



**G CL129DL**

**12 x 12 x 900mm Motorcycle Chain Lock**

Heavy-duty 12mm square link chain, fitted with durable nylon sleeve for avoiding accidental scratching and damage to the bike. Features extra-long 12mm thick shrouded shackle with anti-drill, anti-saw and anti-pick protection on the locking cylinder. Supplied with two keys.

<b>Chain Size:</b>	12 x 12 x 900mm
--------------------	-----------------



**H CLA109DL**

**10.5 x 10.5 x 1500mm Motorcycle Chain & Disc Lock 4\* ART Approved**

Heavy-duty 10.5mm square link chain, fitted with durable nylon sleeve for avoiding accidental scratching and damage to the bike. Features hardened zinc alloy bodied disc lock with anti-drill, anti-saw and anti-pick protection on the locking cylinder. 4\* ART Approval. Supplied with two keys.

<b>Chain Size:</b>	10.5 x 10.5 x 1500mm
<b>ART Approval:</b>	4*

**F BS103**

**Workshop Bicycle Stand**

Adjustable work height and fitted with articulated rubber coated frame clamp preventing damage to paintwork. Features four folding legs with a 1370mm span for added stability and multi-position tool tray to ensure tools are always close to hand.

<b>Minimum Height:</b>	1050mm
<b>Maximum Height:</b>	1750mm
<b>Maximum Load:</b>	30kg
<b>Weight:</b>	6.2kg



## A SEE BELOW

### Lightweight Car Covers

Made from lightweight, anti-scratch material to protect vehicle's paintwork. Side-opening zips give access to vehicle doors without removing cover. Features elastic corners for easy fitting. Fitted with fastening clip to secure cover onto vehicle. Suitable for dust protection and resistant to light rain.

Model No:	Dimensions (L x W x H):
CCES	3800 x 1540 x 1190mm
CCEM	4060 x 1650 x 1220mm
CCEL	4300 x 1690 x 1220mm
CCEXL	4830 x 1780 x 1220mm



## B SEE BELOW

### Car Covers

Ideal for protection, rain or shine, against weathering and fading. 2-Layer cover for extra protection. Inner layer is made from soft anti-scratch material to protect vehicle's paintwork. Elastic corners for easy and secure fitting. Side-opening zip to allow access to the car when covered. Supplied with waterproof storage bag.

Model No:	Dimensions (L x W x H):
CCS	3800 x 1540 x 1190mm
CCM	4060 x 1650 x 1220mm
CCL	4300 x 1690 x 1220mm
CCXL	4830 x 1780 x 1220mm



## C SEE BELOW

### 3-Layer All Seasons Car Covers

Professional all-seasons car covers, manufactured from completely waterproof 3-layer breathable composite material, which allows condensation to evaporate. Can be used inside or outside to protect vehicle from elements that could be potentially damaging. Cover is easy to fit using the elasticated edges which fit around the vehicle's bumper and ties down securely with under car straps. This range of car covers also protects from UV/heat, environmental pollutants, bird droppings plus snow and ice.

Model No:	Dimensions (L x W x H):
SCCS	3800 x 1650 x 1200mm
SCCM	4050 x 1650 x 1200mm
SCCL	4550 x 1650 x 1200mm
SCCXL	5100 x 1780 x 1240mm
SCCXXL	5100 x 1950 x 1520mm



UV stable material ensures cover can be used during Summer months to protect vehicle from heat and the sun's rays without the risk of fabric degradation.



Provides resistance to environmental pollutants, tree sap and bird droppings.



With use of external seams, this cover minimises the risk of abrasion and ensures the cover is completely waterproof.



Protects vehicle against snow and ice, thanks to its waterproof 3-layer design.



Made using a 3-layer cover allowing paintwork to breathe, preventing condensation forming and reducing the risk of damaging the vehicle's paintwork.





**A FGE01**

**Foldable Garage Extension**

Foldable garage extension, perfect for allowing temporary use of a driveway as a garage. Supplied with a powder coated steel frame. 195g/m2 PE Tarp with UV protection and completely waterproof.

<b>Door Size (W x H):</b>	2.5 x 2m
<b>Overall Size (W x D x H):</b>	2.5 x 4.5 x 2.5m
<b>Material:</b>	195g/m2 PE Tarp and Steel
<b>Weight:</b>	122kg

**B SBSC01**

**Outdoor Storage Box**

Manufactured from heavy-duty polypropylene, maintenance-free and fully weatherproof. Features hinged lid which can be padlocked (not included) for added security. Fitted with two carry-handles, closed ventilation and two integral wheels on base for easy manoeuvrability. Ideal for use in multiple domestic applications, including garden tool and furniture storage. Supplied flat-packed and can be easily assembled with no tools required.

Specification:	Width:	Depth:	Height:
<b>External Size:</b>	1120mm	460mm	540mm
<b>Internal Size:</b>	1100mm	450mm	500mm
<b>Maximum Load:</b>	150kg		
<b>Weight:</b>	9.8kg		

**B**

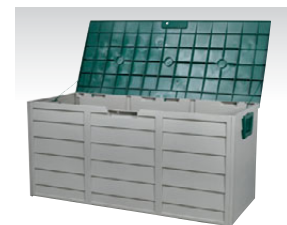





5.5m Length

**A CCS01**  
**Vehicle Storage Shelter**

Made from durable anti-scratch material to protect vehicle's paintwork. Rigid tubular frame with hinged opening for easy-access. Hook-and-loop vents allow increased ventilation while still keeping vehicle protected from elements. Includes anchor points for fixing shelter to driveway/ground (fixings not included). Central padlock hasp and additional ground anchor point for increased security when canopy is closed.

Overall Size (W x D x H): 2.7 x 5.5 x 2m



5.2m Length

**B CPS01**  
**Instant Car Port Shelter**

Allows for temporary or permanent storage of small cars, boats, materials and machinery. Manufactured from a strong, rust resistant thermoset powder coated steel frame and 3-layer heavy-duty polyethylene tarpaulin cover, with rip-stop to help prevent tears. Includes stake pegs to secure unit and side skirting to protect against crosswinds. Features a wide opening double zip door which can be rolled up to provide easy-access. Cover is UV resistant for long-life and gives protection for stored items.

Size (W x D x H): 3 x 5.2 x 2.4m

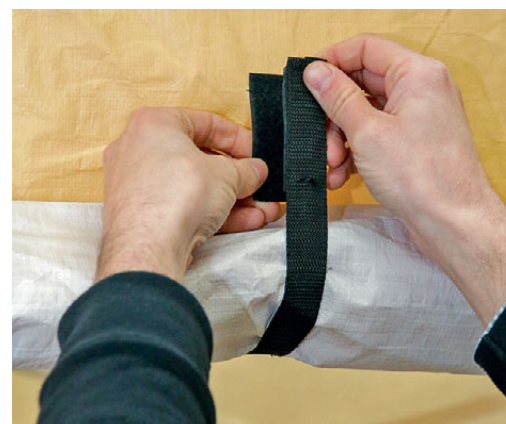

CPS01 is secured using heavy-duty ratchet tie downs.





**C CPS03**  
**Dome Roof Car Port Shelter**

Allows for temporary or permanent storage of small cars, boats, materials and machinery. Manufactured from a strong, rust resistant thermoset powder coated steel frame and 3-layer heavy-duty polyethylene tarpaulin cover, with rip-stop to help prevent tears. Includes stake pegs to secure unit and side skirting to protect against crosswinds. Features a wide opening double zip door which can be rolled up to provide easy-access. Cover is UV resistant for long-life and gives protection for stored items. Features a dome roof design to further protect against strong winds.

**Size (W x D x H):** 4 x 6 x 3.1m



**D CPS02**  
**Instant Car Port Shelter**

Allows for temporary or permanent storage of large cars, boats, materials and machinery. Manufactured from a strong, rust resistant thermoset powder coated steel frame and 3-layer heavy-duty polyethylene tarpaulin cover, with rip-stop to help prevent tears. Includes stake pegs to secure unit and side skirting to protect against crosswinds. Features a wide opening double zip door which can be rolled up to provide easy-access. Cover is UV resistant for long-life and gives protection for stored items.

**Size (W x D x H):** 3.3 x 7.5 x 2.9m



CPS02 & CPS03 feature clips to keep shelter door open when in use.





**A**



**B-E**



**A WPHG01**  
**5V Heated Puffy Gilet**

Water-resistant gilet with three carbon fibre heating elements. Heating elements are in the back and each side of the chest. Three different heat modes controlled by colour changing button (White – Low, Blue – Medium, Red – High). One-size-fits-all design with adjustable chest and waist size. Power bank not included but required (see page 1177), recommended 2A output for optimum use.

**B-E SEE RIGHT**  
**5V Heated Rain Jackets**

Waterproof jackets with three carbon fibre heating elements. Heating elements are in the back and each side of the chest. Three different heat modes controlled by colour changing button (Blue – Low, Green – Medium, Red – High). Power bank not included but required (see page 1177), recommended 2A output for optimum use.

Model No:	Size:
<b>B</b> WPHJ01	Small
<b>C</b> WPHJ02	Medium
<b>D</b> WPHJ03	Large
<b>E</b> WPHJ04	X-Large

**F-G NEW**



Comes with Battery.



**H-O NEW**



Comes with Battery.



**F-G SEE BELOW**

**5V Heated Puffy Gilets - with Power Bank**

Water-resistant gilets with three carbon fibre heating elements. Heating elements are in the back and each side of the chest. Three different heat modes controlled by colour changing button (White – Low, Blue – Medium, Red – High). One-size-fits-all design with adjustable chest and waist size.

**H-O SEE BELOW**

**5V Heated Rain Jackets - with Power Bank**

Water-resistant jackets with three carbon fibre heating elements. Heating elements are in the back and each side of the chest. Three different heat modes controlled by colour changing button (Blue – Low, Green – Medium, Red – High).

Model No:	Contents:	Run Time:
<b>F</b> HG01KIT	WPHG01 - 5V Heated Puffy Gilet 44" to 52" Chest, SPB101 - 10W 10000mAh Portable Power Bank	6hr
<b>G</b> HG02KIT	WPHG01 - 5V Heated Puffy Gilet 44" to 52" Chest, SPB102 - 10W 20000mAh Portable Power Bank	12hr

Model No:	Contents:	Jacket Size:	Run Time:
<b>H</b> HJ01KIT	WPHJ01 - 5V Heated Rain Jacket, SPB101 - 10W 10000mAh Portable Power Bank	Small	6hr
<b>I</b> HJ02KIT	WPHJ02 - 5V Heated Rain Jacket, SPB101 - 10W 10000mAh Portable Power Bank	Medium	6hr
<b>J</b> HJ03KIT	WPHJ03 - 5V Heated Rain Jacket, SPB101 - 10W 10000mAh Portable Power Bank	Large	6hr
<b>K</b> HJ04KIT	WPHJ04 - 5V Heated Rain Jacket, SPB101 - 10W 10000mAh Portable Power Bank	X-Large	6hr
<b>L</b> HJ05KIT	WPHJ01 - 5V Heated Rain Jacket, SPB102 - 10W 20000mAh Portable Power Bank	Small	12hr
<b>M</b> HJ06KIT	WPHJ02 - 5V Heated Rain Jacket, SPB102 - 10W 20000mAh Portable Power Bank	Medium	12hr
<b>N</b> HJ07KIT	WPHJ03 - 5V Heated Rain Jacket, SPB102 - 10W 20000mAh Portable Power Bank	Large	12hr
<b>O</b> HJ08KIT	WPHJ04 - 5V Heated Rain Jacket, SPB102 - 10W 20000mAh Portable Power Bank	X-Large	12hr

