

POWER TOOL ACCESSORIES

 [back to Section List](#)



Abrasive Wheels

929

Abrasives

937-940

Backing Pads

943

Bandsaw Blades

936

Breakers & Chisels

912-915

Buffing & Polishing

941-943

Circular Saw Blades

923

Countersink Bit Sets

893

Cutting & Grinding Discs

919-920

Cutting Oil

936

Deburring Bit Sets

893

Diamond Blades

916-918

Diamond Core Drills

909

Diamond Drills

910

Drill Bits

897-907

Drill Chucks

905

Flap Discs

921-922

Hole Saws

911

Multi-Tool Accessories

933-935

Rotabors

908

Rotary Burrs

894-895

Rotary Tool Accessories

926-928

Sanding Belts & Discs

937-939

Saw Blades

930-932

SDS Breakers & Chisels

912-913

SDS Drill Bits

906-907

Step Drills

896

Wire Brushes

924-925



A AK4704
4pc Multifunction Drill Bit Set
 Multifunction drill bit set to cover most of your drilling needs. Set includes a drill saw, step drill, tube drill and countersink. Drill saw bit can be used as a drill, saw, rotary file, reamer and router.
Contents: Ø4-12mm Step Drill, Ø8-20mm Tube Drill, Ø6mm Drill Saw, Ø12.4mm Countersink



B CSSET6V
6pc 90° Countersink Bit Set
3 x V Flutes
 90° 3 x V Flute design. Set includes popular sized bits. Suitable for light metals and wood. Supplied in a metal storage case.
Contents: Ø6.3, 8.3, 10.4, 12.4, 16.5, 20.5mm



C CSSET40
4pc 90° Slotted Deburring Countersink Drill Bit Set
 Chip removal through the slot prevents excess waste from clogging the workpiece. Ideal for burr, chatter-free deburring and countersinking. More efficient than a standard countersink. Compatible with wood and light metals. Supplied in a metal storage case.
Contents: Ø2-5, 5-10, 10-15, 15-20mm

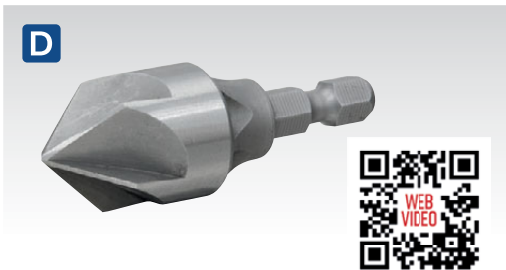

D DB03
Ø3-18mm Internal Deburring/Chamfer Tool
 Designed to clean internal pipe ends quickly and safely. Manufactured with alloy steel cutters to remove damaged metal and burrs. Features a 1/4" Hex shank for use with a drill or hex driver. Applicable for use on pieces from Ø3mm to 18mm in diameter. Suitable for use with a variety of compounds including stainless steel, hardened steel, mild steel, copper, brass, plastic and many more.
Applications: Stainless Steel, Hardened Steel, Mild Steel, Copper, Brass, Wood, Plastic, Fibreglass



E DB04
Ø3-19mm External Deburring/Chamfer Tool
 Designed to clean up and repair threaded fasteners and studding quickly and safely. Fitted with 3 x HSS blades to remove damaged metal and burrs. Features a 1/4" Hex shank for use with a drill or hex driver. Applicable for use on pieces from Ø3mm to 19mm in diameter. Suitable for use with a variety of compounds including stainless steel, hardened steel, mild steel, copper, brass, plastic and many more. Unit is much faster and more accurate than using a file or angle grinder.
Applications: Stainless Steel, Hardened Steel, Mild Steel, Copper, Brass, Wood, Plastic, Fibreglass



F AK4730
9pc Ø10mm Spot Weld Cutter & Drill Bit Set
 Suitable for drilling out spot welds on most vehicle panels. Spot weld cutter features spring loaded centre point to guide cutting crown onto weld. Ø8mm HSS Drill with 5% Cobalt for longer life, suitable for more specialist materials including galvanized, boron and high stress steels. Solid Cobalt stock allows resharping, extending product life. Set includes replacement centre points and cutter crowns. Supplied in metal storage case.
Contents: Spot Weld Cutter, Ø8mm Cobalt Spot Weld Drill, Centre Points (x2), Ø10mm Cutter Crowns (x5)
Spot Weld Cutting Crown (Pack of 2): Z1C2

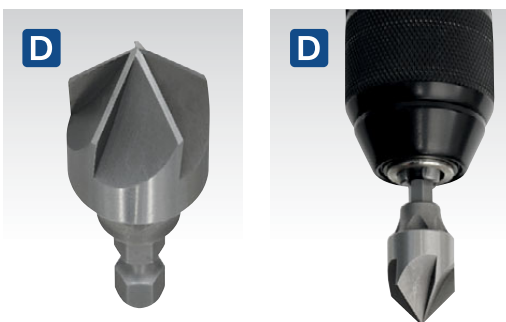

Tungsten Carbide

Tungsten Carbide is much stronger than standard HSS metals and also keeps its cutting edge over a much longer period of time. This in turn gives a much improved finish. Tungsten Carbide rotary burrs are also able to be used at much higher temperatures which again helps prolong tool life when compared against standard HSS versions.

A HSS COBALT
Ø1-10mm
MM



A AK4701
19pc HSS Cobalt Fully Ground Drill Bit Set

Fully ground HSS with 5% Cobalt makes these ideal for drilling extra hard materials. 135° Split point tip enables bits to bite workpiece quickly, reducing the need for centre mark. Drills can be resharpened without affecting their performance. Supplied in metal storage case.

Sizes: Ø1-10mm in 0.5mm increments

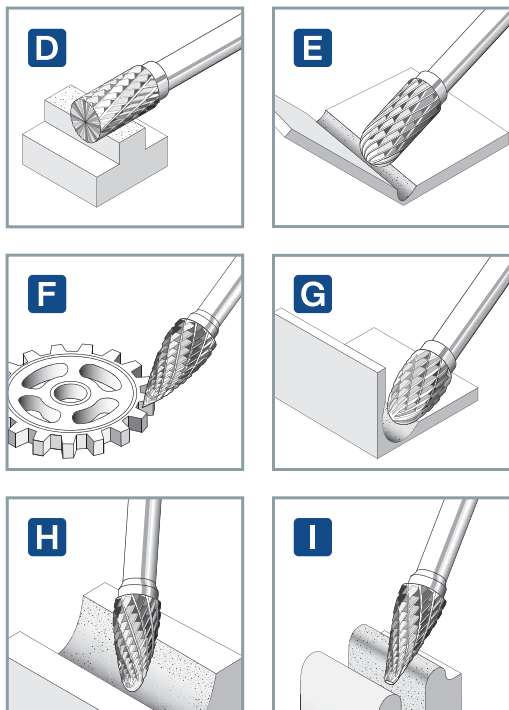

B SDBK3
3pc Tungsten Carbide Rotary Burr Set

Rotary burrs manufactured from Tungsten Carbide with Cylindrical Front End No. 6 cut (universal), Rotary Ball Nose and Arc Pointed Nose shaped heads. For use on soft and hard metal, including welded seams. Supplied in plastic storage box.

Comprises: SDB01, SDB02, SDB03



C SDBK5
5pc Tungsten Carbide Rotary Burr Set

Rotary burrs manufactured from Tungsten Carbide with Cylindrical Front End No. 6 cut (universal), Rotary Ball Nose, Arc Pointed Nose, Arc Round Nose, Conical Ball Nose shaped heads. For use on soft and hard metal, including welded seams. Supplied in plastic storage box.

Comprises: SDB01, SDB02, SDB03, SDB05, SDB06

D-I SEE BELOW
Ø10mm Tungsten Carbide Rotary Burrs - Ø6mm Shaft

Rotary burrs manufactured from Tungsten Carbide with No. 6 cut (universal) with various shaped heads. For use on soft and hard metal, including welded seams. Supplied in plastic storage box. Available individually or as a 3 or 5pc set (see **B** & **C**).

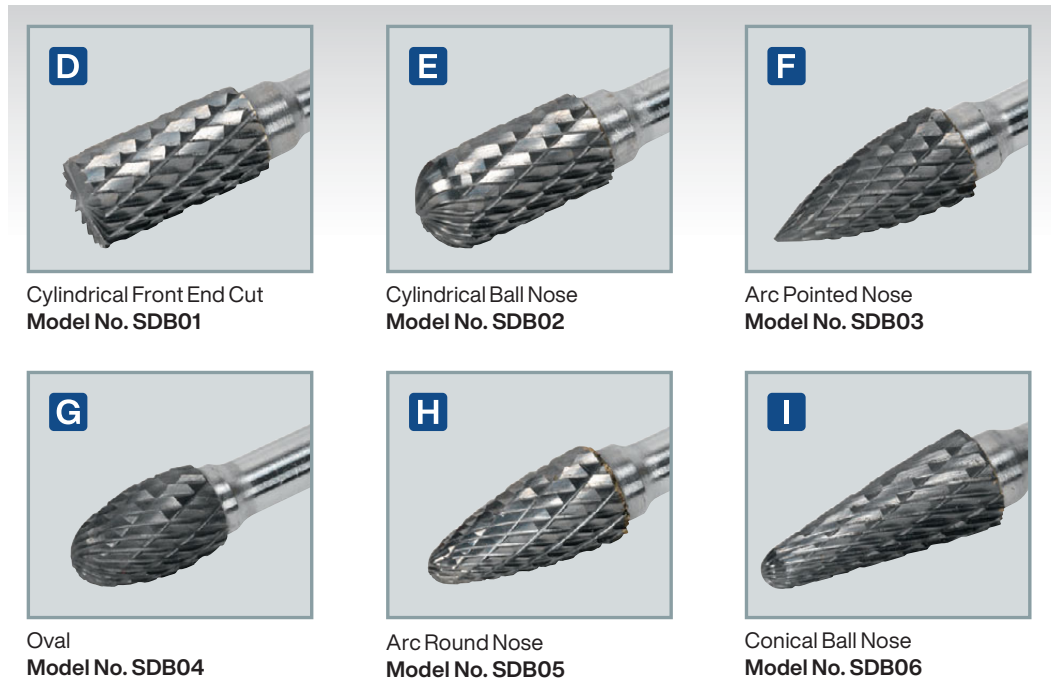

Model No:	Head Shape:	Shaft Diameter:	Head Diameter:	Head Length:	Overall Length:
D SDB01	Cylindrical Front End Cut	Ø6mm	Ø10mm	20mm	65mm
E SDB02	Cylindrical Ball Nose	Ø6mm	Ø10mm	20mm	65mm
F SDB03	Arc Pointed Nose	Ø6mm	Ø10mm	20mm	65mm
G SDB04	Oval	Ø6mm	Ø10mm	16mm	65mm
H SDB05	Arc Round Nose	Ø6mm	Ø10mm	20mm	65mm
I SDB06	Conical Ball Nose	Ø6mm	Ø10mm	25mm	65mm



A MCBSET01
5pc Micro Burr Set

Micro rotary burrs manufactured from Tungsten Carbide, with Ø3mm shanks and various shaped heads. For use on soft and hard metal, including welded seams. Great for porting, gas flowing or any precision detailing jobs. Supplied in plastic storage box.



H SDBC3
3pc Tungsten Carbide Rotary Burr Set Ripper/Coarse

Comprises: SDBC1, SDBC2, SDBC3



O SDBC5
5pc Tungsten Carbide Rotary Burr Set Ripper/Coarse

Comprises: SDBC1, SDBC2, SDBC3, SDBC4, SDBC6



B
Burr Ball
Model No. MCB001



C
Ball Nose Cylinder
Model No. MCB002



D
Cylinder
Model No. MCB003



E
Ball Nose Taper
Model No. MCB004



F
Pointed Tree
Model No. MCB005



G
Ball Nose Tree
Model No. MCB006

B-G SEE BELOW
Ø3mm Micro Carbide Burrs - Packs of 3

Micro rotary burrs manufactured from Tungsten Carbide, with Ø3mm shanks and various shaped heads. For use on soft and hard metal, including welded seams. Great for porting, gas flowing or any precision detailing jobs. Packs of three, supplied in plastic storage box.

Model No:	Head Shape:	Shaft Diameter:	Overall Length:	Head Length:	Pack Qty:
B MCB001	Burr Ball	Ø3mm	38mm	3mm	3
C MCB002	Ball Nose Cylinder	Ø3mm	38mm	16mm	3
D MCB003	Cylinder	Ø3mm	38mm	16mm	3
E MCB004	Ball Nose Taper	Ø3mm	38mm	16mm	3
F MCB005	Pointed Tree	Ø3mm	38mm	16mm	3
G MCB006	Ball Nose Tree	Ø3mm	38mm	16mm	3

I-N SEE BELOW
Ø10mm Tungsten Carbide Rotary Burrs Ripper/Coarse

Rotary burrs manufactured from Tungsten Carbide with coarse teeth for aluminium or plastic cutting. Supplied in plastic storage box. Available individually or as a 3 or 5pc set (see **H** & **O**).



I
Cylindrical Front End Cut
Model No. SDBC1



J
Cylindrical Ball Nose
Model No. SDBC2



K
Oval
Model No. SDBC3



L
Arc Round Nose
Model No. SDBC4



M
Flame
Model No. SDBC5



N
Conical Ball Nose
Model No. SDBC6

Model No:	Head Shape:	Shaft Diameter:	Head Diameter:	Head Length:	Overall Length:
I SDBC1	Cylindrical Front End Cut	Ø6mm	Ø10mm	20mm	65mm
J SDBC2	Cylindrical Ball Nose	Ø6mm	Ø10mm	20mm	65mm
K SDBC3	Oval	Ø6mm	Ø10mm	16mm	65mm
L SDBC4	Arc Round Nose	Ø6mm	Ø10mm	20mm	65mm
M SDBC5	Flame	Ø6mm	Ø10mm	25mm	65mm
N SDBC6	Conical Ball Nose	Ø6mm	Ø10mm	25mm	65mm



Double Straight Flute

Double flute allows faster swarf removal than a standard single flute found on cheaper alternatives.



Double Spiral Flute

Much like the double straight flutes, these offer faster swarf removal than a standard single flute step drill. The two spiral flutes offer even greater efficiency, which in turn helps to keep the temperature down, resulting in a longer life expectancy of the tool.

M2 Steel

Our M2 metal step drills are more durable and longer lasting than standard 4341 steel and cheaper versions that you may see elsewhere. As well as lasting longer, they also cut through tougher materials with less effort and more efficiency.



I CP20VDDKIT
20V SV20 Series Ø13mm Combi Drill/Driver Kit - 2 Batteries

For full details, see page 847.



For our full range of SV20 Series Power Tools, see pages 844 to 872.

A

MM

DOUBLE STRAIGHT FLUTE



A AK4746
3pc Double Flute HSS 4341 Step Drill Bit Set

Three high-speed HSS 4341 double flute step drills. Double straight flutes for efficient swarf clearance. 18 Sizes covered by three drill bits. Supplied in flip-up metal case.

Size Coverage #1:	Ø4, 5, 6, 7, 8, 9, 10, 11, 12mm
Size Coverage #2:	Ø4, 6, 8, 10, 12, 14, 16, 18, 20, 22mm
Size Coverage #3:	Ø4, 6, 8, 10, 12, 14, 16, 18, 20, 22, 24, 26, 28, 30mm

B

HSS M2 High Wear Resistance

MM

DOUBLE STRAIGHT FLUTE



B AK4733
3pc Double Flute HSS M2 Step Drill Bit Set

Three high-speed HSS M2 double flute step drills. Double straight flutes for efficient swarf clearance. Allows clog-free, precision drilling of 18 different size holes with just three bits. Supplied in a flip-up metal case.

Size Coverage #1:	Ø4, 5, 6, 7, 8, 9, 10, 11, 12mm
Size Coverage #2:	Ø4, 6, 8, 10, 12, 14, 16, 18, 20, 22mm
Size Coverage #3:	Ø4, 6, 8, 10, 12, 14, 16, 18, 20, 22, 24, 26, 28, 30mm

C-D

MM

Model No:	Sizes:
C AK4744	Ø4, 6, 8, 10, 12, 14, 16, 18, 20, 22mm
D AK4745	Ø4, 6, 8, 10, 12, 14, 16, 18, 20, 22, 24, 26, 28, 30mm

E-F

MM

Model No:	Sizes:
E AK4747	Ø4, 6, 8, 10, 12, 14, 16, 18, 20, 22mm
F AK4748	Ø4, 6, 8, 10, 12, 14, 16, 18, 20, 22, 24, 26, 28, 30mm

G-H

HSS M2 High Wear Resistance

MM

Model No:	Sizes:
G AK4722	Ø4, 6, 8, 10, 12, 14, 16, 18, 20, 22mm
H AK4732	Ø4, 6, 8, 10, 12, 14, 16, 18, 20, 22, 24, 26, 28, 30mm

J

MM

DOUBLE SPIRAL FLUTE



J AK4749
3pc Spiral Flute HSS 4341 Step Drill Bit Set

Three high-speed HSS 4341 double spiral flute step drills. Double spiral flutes for efficient swarf clearance. Allows clog-free precision drilling of up to 18 different hole sizes. Supplied in flip-up metal case.

Size Coverage #1:	Ø4, 5, 6, 7, 8, 9, 10, 11, 12mm
Size Coverage #2:	Ø4, 6, 8, 10, 12, 14, 16, 18, 20, 22mm
Size Coverage #3:	Ø4, 6, 8, 10, 12, 14, 16, 18, 20, 22, 24, 26, 28, 30mm

K

HSS M2 High Wear Resistance

MM

DOUBLE SPIRAL FLUTE



K AK4743
3pc Spiral Flute HSS M2 Step Drill Bit Set

Three high-speed HSS M2 spiral flute step drills. Double spiral flutes for efficient swarf clearance. Allows clog-free, precision drilling of 18 different size holes with just three bits. Supplied in flip-up metal case.

Size Coverage #1:	Ø4, 5, 6, 7, 8, 9, 10, 11, 12mm
Size Coverage #2:	Ø4, 6, 8, 10, 12, 14, 16, 18, 20, 22mm
Size Coverage #3:	Ø4, 6, 8, 10, 12, 14, 16, 18, 20, 22, 24, 26, 28, 30mm

A MM



A SEE BELOW
HSS Twist Drill Bits

Model No:	Size:	Overall Length:	Pack Qty:
HSS1	Ø1mm	30mm	2
HSS1.5	Ø1.5mm	30mm	2
HSS2	Ø2mm	47mm	2
HSS2.5	Ø2.5mm	55mm	2
HSS3	Ø3mm	60mm	1
HSS3.5	Ø3.5mm	70mm	1
HSS4	Ø4mm	75mm	1
HSS4.5	Ø4.5mm	80mm	1
HSS5	Ø5mm	85mm	1

Model No:	Size:	Overall Length:	Pack Qty:
HSS5.5	Ø5.5mm	85mm	1
HSS6	Ø6mm	90mm	1
HSS6.5	Ø6.5mm	100mm	1
HSS7	Ø7mm	105mm	1
HSS7.5	Ø7.5mm	105mm	1
HSS8	Ø8mm	115mm	1
HSS8.5	Ø8.5mm	115mm	1
HSS9	Ø9mm	125mm	1
HSS9.5	Ø9.5mm	125mm	1

Model No:	Size:	Overall Length:	Pack Qty:
HSS10	Ø10mm	135mm	1
HSS10.5	Ø10.5mm	135mm	1
HSS11	Ø11mm	140mm	1
HSS11.5	Ø11.5mm	145mm	1
HSS12	Ø12mm	150mm	1
HSS12.5	Ø12.5mm	155mm	1
HSS13	Ø13mm	160mm	1

B MM



B SEE BELOW
Blacksmith Drill Bits

Model No:	Size:	Overall Length:	Pack Qty:
BSB10.5	Ø10.5mm	130mm	1
BSB11.0	Ø11mm	140mm	1
BSB11.5	Ø11.5mm	140mm	1
BSB12.0	Ø12mm	150mm	1
BSB12.5	Ø12.5mm	150mm	1
BSB13.0	Ø13mm	150mm	1
BSB13.5	Ø13.5mm	160mm	1
BSB14.0	Ø14mm	160mm	1
BSB14.5	Ø14.5mm	170mm	1
BSB15.0	Ø15mm	170mm	1

Model No:	Size:	Overall Length:	Pack Qty:
BSB15.5	Ø15.5mm	180mm	1
BSB16.0	Ø16mm	180mm	1
BSB16.5	Ø16.5mm	180mm	1
BSB17.0	Ø17mm	185mm	1
BSB17.5	Ø17.5mm	190mm	1
BSB18.0	Ø18mm	190mm	1
BSB18.5	Ø18.5mm	200mm	1
BSB19.0	Ø19mm	200mm	1
BSB19.5	Ø19.5mm	205mm	1
BSB20.0	Ø20mm	205mm	1

Model No:	Size:	Overall Length:	Pack Qty:
BSB20.5	Ø20.5mm	200mm	1
BSB21.0	Ø21mm	210mm	1
BSB21.5	Ø21.5mm	220mm	1
BSB22.0	Ø22mm	220mm	1
BSB22.5	Ø22.5mm	220mm	1
BSB23.0	Ø23mm	215mm	1
BSB23.5	Ø23.5mm	230mm	1
BSB24.0	Ø24mm	230mm	1
BSB24.5	Ø24.5mm	235mm	1
BSB25.0	Ø25mm	240mm	1

C



Siegen

C S01039
6pc HSS Drill Bit Set

HSS Roll forged drill bits manufactured to DIN338. Suitable for general workshop use in both hand and pillar drill applications. Six popular sizes supplied in storage case.

Contents:	Ø2, 3, 4, 5, 6, 8mm
-----------	---------------------

D



D DBS19RF
19pc HSS Roll Forged Drill Bit Set

General purpose HSS roll forged drill bits manufactured to DIN 338. 118° Point tip. Efficient clog-free swarf clearance. Suitable for use with both hand and pillar drills. Supplied in flip-up metal storage case.

Contents:	Ø1, 1.5, 2, 2.5, 3, 3.5, 4, 4.5, 5, 5.5, 6, 6.5, 7, 7.5, 8, 8.5, 9, 9.5, 10mm
-----------	---

E



E SEE BELOW
SG Iron Industrial Vices

Bench mounting SG iron vices, impact and fatigue resistant, suitable for professionals. Features jaws made from high carbon steel to provide long-life durability and a heavy-duty anvil strong enough to withstand the rigours of daily use. Precision engineered screw thread ensures smooth and easy jaw operation. Swivel base mounts directly onto workbench.

Model No:	Jaw Width:	Jaw Opening:	Weight:
SGV150	150mm	150mm	14.4kg
SGV200	200mm	200mm	20.5kg

A SEE BELOW**Individual HSS Roll Forged Drill Bits - Metric**

Model No:	Size:	Pack Qty:
DB010RF	Ø1mm	10
DB015RF	Ø1.5mm	10
DB020RF	Ø2mm	10
DB025RF	Ø2.5mm	10
DB030RF	Ø3mm	10
DB035RF	Ø3.5mm	10
DB040RF	Ø4mm	10
DB045RF	Ø4.5mm	10
DB050RF	Ø5mm	10
DB055RF	Ø5.5mm	10
DB060RF	Ø6mm	10
DB065RF	Ø6.5mm	10
DB070RF	Ø7mm	10
DB075RF	Ø7.5mm	10
DB080RF	Ø8mm	10
DB085RF	Ø8.5mm	10
DB090RF	Ø9mm	10
DB095RF	Ø9.5mm	10
DB100RF	Ø10mm	5
DB105RF	Ø10.5mm	5
DB110RF	Ø11mm	5
DB115RF	Ø11.5mm	5
DB120RF	Ø12mm	5
DB125RF	Ø12.5mm	5
DB130RF	Ø13mm	5

**HSS ROLL FORGED****B SEE BELOW****Individual HSS Fully Ground Drill Bits - Metric**

Model No:	Size:	Pack Qty:
DB010FG	Ø1mm	10
DB015FG	Ø1.5mm	10
DB020FG	Ø2mm	10
DB025FG	Ø2.5mm	10
DB030FG	Ø3mm	10
DB035FG	Ø3.5mm	10
DB040FG	Ø4mm	10
DB045FG	Ø4.5mm	10
DB050FG	Ø5mm	10
DB055FG	Ø5.5mm	10
DB060FG	Ø6mm	10
DB065FG	Ø6.5mm	10
DB070FG	Ø7mm	10
DB075FG	Ø7.5mm	10
DB080FG	Ø8mm	10
DB085FG	Ø8.5mm	10
DB090FG	Ø9mm	10
DB095FG	Ø9.5mm	10
DB100FG	Ø10mm	5
DB105FG	Ø10.5mm	5
DB110FG	Ø11mm	5
DB115FG	Ø11.5mm	5
DB120FG	Ø12mm	5
DB125FG	Ø12.5mm	5
DB130FG	Ø13mm	5

**HSS FULLY GROUND****C SEE BELOW****Individual HSS Fully Ground Cobalt Drill Bits - Metric**

Model No:	Size:	Pack Qty:
DB010CB	Ø1mm	10
DB015CB	Ø1.5mm	10
DB020CB	Ø2mm	10
DB025CB	Ø2.5mm	10
DB030CB	Ø3mm	10
DB035CB	Ø3.5mm	10
DB040CB	Ø4mm	10
DB045CB	Ø4.5mm	10
DB050CB	Ø5mm	10
DB055CB	Ø5.5mm	10
DB060CB	Ø6mm	10
DB065CB	Ø6.5mm	10
DB070CB	Ø7mm	10
DB075CB	Ø7.5mm	10
DB080CB	Ø8mm	10
DB085CB	Ø8.5mm	10
DB090CB	Ø9mm	10
DB095CB	Ø9.5mm	10
DB100CB	Ø10mm	5
DB105CB	Ø10.5mm	5
DB110CB	Ø11mm	5
DB115CB	Ø11.5mm	5
DB120CB	Ø12mm	5
DB125CB	Ø12.5mm	5
DB130CB	Ø13mm	5

**HSS FULLY GROUND COBALT****A SEE BELOW****Individual HSS Roll Forged Drill Bits - Imperial**

Model No:	Size:	Pack Qty:
DBI18RF	Ø1/8"	10
DBI316RF	Ø3/16"	10
DBI732RF	Ø7/32"	10
DBI14RF	Ø1/4"	10

B SEE BELOW**Individual HSS Fully Ground Drill Bits - Imperial**

Model No:	Size:	Pack Qty:
DBI18FG	Ø1/8"	10
DBI316FG	Ø3/16"	10
DBI732FG	Ø7/32"	10
DBI14FG	Ø1/4"	10

C SEE BELOW**Individual HSS Fully Ground Cobalt Drill Bits - Imperial**

Model No:	Size:	Pack Qty:
DBI18CB	Ø1/8"	10
DBI316CB	Ø3/16"	10
DBI732CB	Ø7/32"	10
DBI14CB	Ø1/4"	10

**D AK9910****10pc Ø1/8" Double End Drill Bit Set**

High-speed steel double end drill bits. Ø1/8" Size for pop riveting. Supplied in plastic tube.

Contents: Ø1/8" (3.2mm) (x10)

**E****Solid Carbide****E AK4740****Ø8mm Solid Carbide Spot Weld Drill Bit**

Suitable for drilling out spot welds on "Ultra High Strength Steel" also known as Boron steels, can also be used on galvanized stress steels. Packed in high-density case for safe storage.

Diameter:	Ø8mm
Length:	44mm

F**HSS COBALT****F SEE BELOW****HSS Cobalt Spot Weld Drill Bits**

HSS with 5% Cobalt for longer life. Suitable for drilling out spot welds on most common vehicle panels, including galvanized and high stress steels.

Model No:	Size:	Length:
AK4728	Ø6mm	66mm
AK4734	Ø8mm	80mm

G**G AK4730****9pc Ø10mm Spot Weld Cutter & Drill Bit Set**

Suitable for drilling out spot welds on most vehicle panels. Spot weld cutter features spring loaded centre point to guide cutting crown onto weld. 8mm HSS drill with 5% Cobalt for longer life, suitable for more specialist materials including galvanized, boron and high stress steels. Solid Cobalt stock allows resharpener, extending product life. Set includes replacement centre points and cutter crowns. Supplied in metal storage case.

Contents: Spot Weld Cutter, Ø8mm Cobalt Spot Weld Drill, Centre Points (x2), Ø10mm Cutter Crowns (x5)	
Replacement Cutters (Pack of 2):	Z1C2

118°

118° Split Point Drill Bits

118° Point angles are used primarily in softer materials such as mild steels and cast irons. 135° Split point should be used to cut harder steel materials.

135° Split Point



135° Split Point Drill Bits

With a 135° drill point, you get thicker chips which allows holes to be drilled faster especially when coupled with HSS fully ground off cobalt drill bits. The length of the lips on a 135° point drill, measured from axis to the outer corners, is relatively short. This enables quicker penetration into the workpiece and reduces thrust and abrasion along the cutting edges.

Roll Forged Drill Bits

Entry level drills with 118° tips are ideal for use on softer materials such as mild steel. These drills are perfect for occasional use.

Fully Ground Drill Bits

These are higher quality than roll forged drill bits, featuring 135° tips which allow holes to be drilled faster. Longer lasting and ideal for regular use.

Cobalt Drill Bits

Cobalt drills are much stronger and hard wearing than standard drill bits meaning that they will also last much longer. As well as being stronger than other drill bits, they are able to cut through hardened materials such as cast iron and stainless steel. Cobalt drill bits are our highest quality drill bit and will outlast both roll forged and fully ground versions.

A

Roll Forged

MM



A DBS170RF

170pc HSS Roll Forged Drill Bit Assortment

General purpose HSS roll forged drill bits manufactured to DIN 338. 118° Point tip. Efficient clog-free swarf clearance. Suitable for use with both hand and pillar drills.

Contents: Ø1, 1.5, 2, 2.5, 3, 3.5, 4, 4.5, 5, 5.5, 6, 6.5, 7, 7.5, 8mm (10 of each), Ø8.5, 9, 9.5, 10mm (5 of each)

B

Fully Ground

MM



B DBS99FG

99pc Fully Ground Drill Bit Set

HSS Fully ground drill bit set. 135° Split point is self-centring which helps to reduce thrust, friction and heat and aids easier penetration. Efficient clog-free swarf clearance. Supplied in a metal storage case.

Contents: Ø1.5 (x16), 2 (x16), 2.5 (x15), 3 (x10), 3.2 (x10), 3.5 (x8), 4 (x8), 4.5 (x3), 5 (x3), 5.5 (x2), 6 (x2), 6.5 (x2), 8 (x2), 10mm (x2)

C

Fully Ground

MM



C DBS170FG

170pc HSS Fully Ground Drill Bit Assortment

Fully ground HSS drill bits manufactured to DIN 338. 135° Split point is self-centring which helps to reduce thrust, friction and heat and aids easier penetration. Efficient clog-free swarf clearance. Suitable for use with both hand and pillar drills, particularly on high carbon steels and copper. Supplied in tough composite storage case.

Contents: Ø1, 1.5, 2, 2.5, 3, 3.5, 4, 4.5, 5, 5.5, 6, 6.5, 7, 7.5, 8mm (10 of each), Ø8.5, 9, 9.5, 10mm (5 of each)

D

HSS COBALT

MM



D DBS99CB

99pc HSS Cobalt Fully Ground Drill Bit Set

135° Split point self-centring tips make for easier penetration. 5% Cobalt helps to increase life of drill bit. Suitable for drilling high carbon steel and stainless steel. Supplied in a metal storage case.

Contents: Ø1.5 (x16), 2 (x16), 2.5 (x15), 3 (x10), 3.2 (x10), 3.5 (x8), 4 (x8), 4.5 (x3), 5 (x3), 5.5 (x2), 6 (x2), 6.5 (x2), 8 (x2), 10mm (x2)

E

HSS COBALT

MM



E DBS170CB

170pc HSS Cobalt Fully Ground Drill Bit Assortment

Fully ground HSS Cobalt drill bits manufactured to DIN 338. 5% Cobalt gives increased heat hardness which helps extend the life of the drill bit. 135° Split point is self-centring which helps to reduce thrust and aids an easier penetration. Efficient clog-free swarf clearance. Suitable for drilling high carbon steel and stainless steel. Supplied in tough composite storage case.

Contents: Ø1, 1.5, 2, 2.5, 3, 3.5, 4, 4.5, 5, 5.5, 6, 6.5, 7, 7.5, 8mm (10 of each), Ø8.5, 9, 9.5, 10mm (5 of each)



A AK3715HSS
15pc HSS Drill Bit Set

Set consists of 15 titanium nitride coated high-speed steel drills. Popular range of sizes. Supplied in plastic storage box with rubberised, non-slip coating.

Contents: Ø1.5 (x2), 2 (x2), 2.5 (x2), 3, 3.2, 3.5, 4, 4.5, 5, 6, 8, 10mm



B AK3715M
15pc Masonry Drill Bit Set

Set consists of 15 tungsten steel masonry drills. Popular selection of sizes. Supplied in plastic storage box with rubberised, non-slip coating.

Contents: Ø3 (x3), 4 (x3), 5 (x3), 6 (x2), 8 (x2), 10mm (x2)



C S01039
6pc HSS Drill Bit Set

HSS Roll forged drill bits manufactured to DIN338. Suitable for general workshop use in both hand and pillar drill applications. Six popular sizes supplied in storage case.

Contents: Ø2, 3, 4, 5, 6, 8mm

Always wear eye protection when using these tools. For our range of safety equipment, see pages 1276 to 1301.

D AK8189
5pc Left-Hand Spiral Drill Bit Set

Left-hand drill bits, used for the extraction of snapped studs, screws or fixings. Manufactured from 4121 HSS steel. Supplied in display case.

Contents: Ø3.2, 4.8, 6.4, 8, 8.7mm



E-F SEE BELOW
Edge Ground HSS Drill Bit Sets

Edge ground HSS drill bits manufactured to DIN 338, with a coating to help reduce friction and heat. Suitable for general workshop use in both hand and pillar drill applications. Supplied in flip-up metal storage case.

Model No:	Description:
E S0868	Ø1 - 10mm in 0.5mm increments, 19pc
F S0938	Ø1 - 13mm in 0.5mm increments, 25pc



G-H SEE BELOW
HSS Roll Forged Drill Bit Sets

General purpose HSS roll forged drill bits manufactured to DIN 338. 118° Point tip. Efficient clog-free swarf clearance. Suitable for use with both hand and pillar drills. Supplied in flip-up metal storage case.

Model No:	Description:
G DBS19RF	Ø1 - 10mm in 0.5mm increments, 19pc
H DBS25RF	Ø1 - 13mm in 0.5mm increments, 25pc





A-B SEE BELOW
HSS Fully Ground Drill Bit Sets

Fully ground HSS drill bits designed to reduce friction and heat. 135° Split point enables bits to bite workpiece to start drilling. Efficient clog-free swarf clearance. Ideal for use on high carbon steels, copper and plastics. Supplied in storage case.

Model No:	Description:
A AK47191	Ø1 - 10mm in 0.5mm increments, 19pc
B AK47251	Ø1 - 13mm in 0.5mm increments, 25pc

C-D SEE BELOW
HSS Fully Ground Drill Bit Sets

Manufactured to DIN 338. 135° Split point tip is self-centring, making for easier penetration. Efficient clog-free swarf clearance. Ideal for use on stainless steel and copper. Supplied in storage case.

Model No:	Description:
C AK4719	Ø1 - 10mm in 0.5mm increments, 19pc
D AK4725	Ø1 - 13mm in 0.5mm increments, 25pc



E-F SEE BELOW
HSS Tri-Point M2 Drill Bit Sets

Tri-point, self-centring tip allows for a quicker cut. Three flatted shank for improved chuck grip in sizes 5mm and above. Engineered design allows drilling on curved surfaces. Supplied in a plastic storage case with rubber corner protectors.

Model No:	Description:
E AK4705	Ø1 - 10mm in 0.5mm increments, 19pc
F AK4706	Ø1 - 13mm in 0.5mm increments, 25pc

G-H SEE BELOW
HSS Cobalt Fully Ground Drill Bit Sets

Fully ground HSS with 5% Cobalt makes these ideal for drilling extra hard materials. 135° Split point tip enables bits to bite workpiece quickly, reducing the need for centre mark. Drills can be resharpened without affecting their performance. Supplied in metal storage case.

Model No:	Description:
G AK4701	Ø1 - 10mm in 0.5mm increments, 19pc
H AK4702	Ø1 - 13mm in 0.5mm increments, 25pc



A AK3715W
15pc Brad Point Wood Drill Bit Set
 Brad point tips and outer spurs allow for faster and more accurate drilling into both hard and soft woods. Popular range of sizes. Supplied in plastic storage box with rubberised, non-slip coating.

Contents: Ø3 (x3), 3.5 (x2), 4 (x2), 4.5, 5, 5.5, 6, 6.5, 7, 8, 10mm



B AK3718MW
18pc Wood/Masonry Drill Bit Set
 Set consists of nine brad point drills and nine tungsten steel masonry drills. Popular range of sizes. Supplied in plastic storage box with rubberised, non-slip coating.

Contents: Masonry; Ø3, 3, 4, 4, 5, 5, 6, 8, 10mm, Wood; Ø3, 3, 4, 4, 5, 5, 6, 8, 10mm



C AK3707FW
7pc 1/4"Hex Shank Flat Wood Drill Bit Set
 Set consists of seven titanium coated flat wood drills. 1/4" Shank allows for a quick change between different drill bits. Popular range of sizes. Supplied in plastic storage box with rubberised, non-slip coating.

Contents: Ø10, 12, 16, 19, 22, 25, 32mm



D AK3HD
3pc Hinge Drill Set
 Use hinge as template by drilling directly through the holes. Spring-loaded sleeve has a chamfered tip to position centrally in hole. 1/4"Hex shank.

Contents: Hinge Drill Bits; 7/64" x 87mm, 9/64" x 89mm, 11/64" x 98mm, 2.5mm Hex Key



E SEE BELOW
Flat Wood Drill Bits

Fully hardened high performance drill bits, for use in wood and wood-like materials. Hex shank for precise and extra grip. Supplied in plastic wallets.

Model No:	Size:	Overall Length:
FWB60	Ø6mm	152mm
FWB80	Ø8mm	152mm
FWB10	Ø10mm	152mm
FWB12	Ø12mm	152mm
FWB13	Ø13mm	152mm
FWB14	Ø14mm	152mm
FWB16	Ø16mm	152mm

Model No:	Size:	Overall Length:
FWB18	Ø18mm	152mm
FWB20	Ø20mm	152mm
FWB22	Ø22mm	152mm
FWB24	Ø24mm	152mm
FWB25	Ø25mm	152mm
FWB28	Ø28mm	152mm
FWB30	Ø30mm	152mm

Model No:	Size:	Overall Length:
FWB32	Ø32mm	152mm
FWB35	Ø35mm	152mm
FWB38	Ø38mm	152mm



F FWBEXT
300mm Flat Wood Bit Extension

Hex shank for precise and extra grip. Two grub screws for secure fitting of flat wood drill bits.

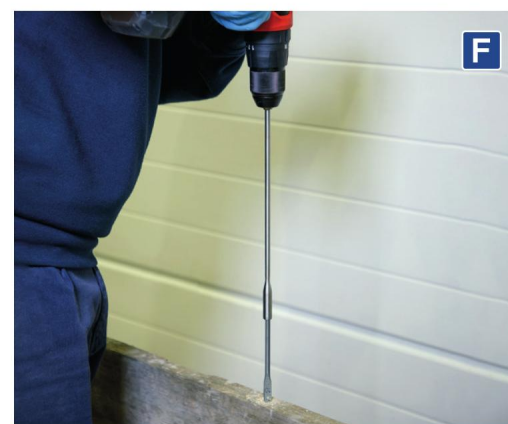



A SEE BELOW

Auger Wood Drill Bits

These quality auger wood drill bits have a hexagonal shank for higher torque ranges demanded by this drill type. Drill bits are fully hardened and have a screw point to aid location and smooth drilling. Supplied in a plastic wallet.

Model No:	Size:	Overall Length:
AW6X155	Ø6mm	155mm
AW6X235	Ø6mm	235mm
AW8X155	Ø8mm	155mm
AW8X235	Ø8mm	235mm
AW8X460	Ø8mm	460mm
AW10X155	Ø10mm	155mm
AW10X235	Ø10mm	235mm
AW10X460	Ø10mm	460mm
AW10X600	Ø10mm	600mm
AW12X155	Ø12mm	155mm
AW12X235	Ø12mm	235mm
AW12X460	Ø12mm	460mm
AW12X600	Ø12mm	600mm
AW13X155	Ø13mm	155mm
AW13X235	Ø13mm	235mm
AW13X460	Ø13mm	460mm
AW14X155	Ø14mm	155mm
AW14X235	Ø14mm	235mm
AW14X460	Ø14mm	460mm

Model No:	Size:	Overall Length:
AW14X600	Ø14mm	600mm
AW16X100	Ø16mm	100mm
AW16X155	Ø16mm	155mm
AW16X235	Ø16mm	235mm
AW16X460	Ø16mm	460mm
AW16X600	Ø16mm	600mm
AW18X155	Ø18mm	155mm
AW18X235	Ø18mm	235mm
AW18X460	Ø18mm	460mm
AW18X600	Ø18mm	600mm
AW20X100	Ø20mm	100mm
AW20X155	Ø20mm	155mm
AW20X235	Ø20mm	235mm
AW20X460	Ø20mm	460mm
AW20X600	Ø20mm	600mm
AW22X155	Ø22mm	155mm
AW22X235	Ø22mm	235mm
AW22X460	Ø22mm	460mm
AW22X600	Ø22mm	600mm

Model No:	Size:	Overall Length:
AW25X100	Ø25mm	100mm
AW25X155	Ø25mm	155mm
AW25X235	Ø25mm	235mm
AW25X460	Ø25mm	460mm
AW25X600	Ø25mm	600mm
AW28X155	Ø28mm	155mm
AW28X235	Ø28mm	235mm
AW28X460	Ø28mm	460mm
AW28X600	Ø28mm	600mm
AW30X155	Ø30mm	155mm
AW30X235	Ø30mm	235mm
AW30X460	Ø30mm	460mm
AW30X600	Ø30mm	600mm
AW32X155	Ø32mm	155mm
AW32X235	Ø32mm	235mm
AW32X460	Ø32mm	460mm
AW32X600	Ø32mm	600mm

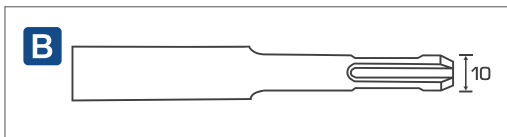

B SEE BELOW

SDS Plus Auger Wood Drill Bits

SDS Plus auger wood drill bits are to the same specification as the auger drill bits but with the SDS Plus shank. Ideal for use with 2kg SDS Plus drills with hammer action switched off. Supplied in a plastic wallet.

Model No:	Size:	Overall Length:
SA6X200	Ø6mm	200mm
SA8X200	Ø8mm	200mm
SA10X235	Ø10mm	235mm
SA12X235	Ø12mm	235mm
SA13X235	Ø13mm	235mm
SA14X235	Ø14mm	235mm
SA16X235	Ø16mm	235mm
SA19X235	Ø19mm	235mm
SA20X235	Ø20mm	235mm
SA22X235	Ø22mm	235mm
SA25X235	Ø25mm	235mm

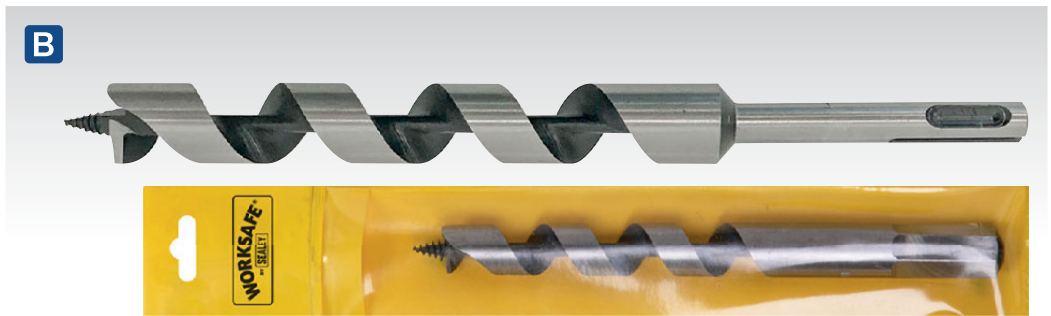

For our range of Safety Goggles and Gloves, see pages 1277 to 1287.



C DJ02
7pc Angled Pocket Dowelling Jig Set
 Pocket-sized 15° angled dowel jig set. Set includes 6, 8, 10mm drill bit guides and adaptor.

D CP20VDD
20V Ø13mm Cordless Combi Drill/Driver
 For full details, see page 847.

Variable Speed
SV20
 SERIES

Hex Shank

Hex shank drill bits are ideal for when you need to change between multiple drill bits quickly and saves the need to constantly have to loosen and re-tighten your chuck. The shape of these drill bits also means that you get more grip, making these perfect for use on harder materials. Always make sure that the bit has been fully tightened before use to ensure that it drills straight or else it may cause breakage.

Ø6mm Shank

These are the most common sizes of drill bits found on the market and offer incredible reliability. They have a Ø6mm diameter and will fit into most hand and pillar drills.

118° 118° Split Point Drill Bits

118° Point angles are used primarily in softer materials such as mild steels and cast irons. 135° Split point drills should be used to cut harder steel materials.

135° Split Point Drill Bits

With a 135° drill point, you get thicker chips which allow holes to be drilled faster, especially when coupled with HSS fully ground off cobalt drill bits. The length of the lips on a 135° point drill, measured from axis to the outer corners, is relatively short. This enables quicker penetration into the workpiece and reduces thrust and abrasion along the cutting edges.

Roll Forged Drill Bits

Entry level drills with 118° tips are ideal for use on softer materials such as mild steel. These drills are perfect for occasional use.

Fully Ground Drill Bits

These are higher quality than roll forged drill bits, featuring 135° tips which allow holes to be drilled faster. Longer lasting and ideal for regular use.

Cobalt Drill Bits

Cobalt drills are much stronger and hard wearing than standard drill bits, meaning that they will also last much longer. As well as being stronger than other drill bits, they are able to cut through hardened materials such as cast iron and stainless steel. Cobalt drill bits are our highest quality drill bit and will outlast both roll forged and fully ground versions.



A AK4720
20pc 1/4"Hex Shank Assorted Drill Bit Set

Comprehensive set of drill bits for use on wood, masonry and metal. Fitted with 1/4"Hex shank for quick and convenient changing. Supplied in tool roll.

Contents: Drill Bits; HSS Coated - Ø3 (x2), 4 (x2), 5, 6, 8, 10mm, Wood - Ø3, 4, 5, 6, 8, 10mm, Masonry - Ø3, 4, 5.5, 6, 8, 10mm

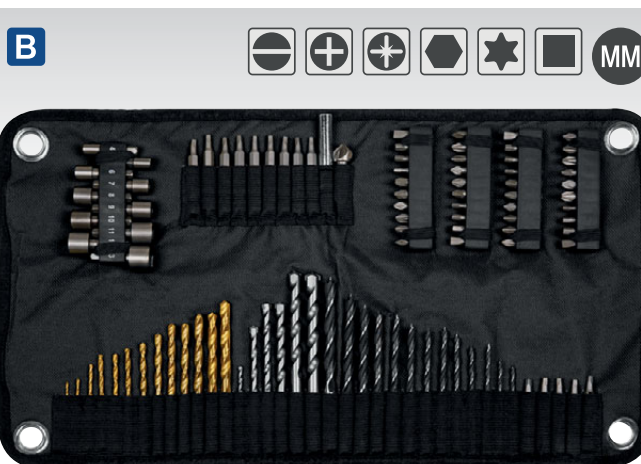

B AK4798
98pc Drill & Bit Accessory Set

Comprehensive set of drill bits for use on wood, masonry and metal. Range of 25 and 50mm bits; Slotted, Phillips, Pozi, TRX-Star*, nut drivers and countersink bit. Stainless steel magnetic bit holder. Supplied in tool roll.

Contents: Drill Bits; HSS Coated - Ø1.5, 2, 2.5, 3, 3.2, 3.5, 4, 4.5, 4.8, 5, 5.5, 6, 6.5mm, Masonry - Ø3, 5.5, 6, 7, 8, 10mm, Wood - Ø3, 3.2, 3.5, 4, 4.5, 4.8, 5, 5.5, 6, 6.5, 7, 7.5, 8mm, 25mm Bits; Slotted - 4, 5, 6, 7mm, Phillips - #0 (x2), #1 (x2), #2 (x3), #3 (x2), Pozi - #0 (x2), #1 (x3), #2 (x4), #3 (x2), TRX-Star* - T10, T15, T20, T25, T27, T30, Hex - 3, 4 (x2), 5 (x2), 6mm, Square Drive - Sq1, Sq2, Sq3, 50mm Bits; Slotted - 4, 6, 7mm, Phillips - #0, #1, #2, #3, Pozi - #1, #2 (x2), #3, TRX-Star* - T10, T15, T20, Nut Drivers; 5 (x2), 6, 7, 8, 9, 10, 11, 12, 13mm, Stainless Steel Bit Holder, Countersink Bit



C AK3735
35pc Drill & Bit Accessory Set

Comprehensive set of drill bits for use on wood, masonry and metal. Manufactured to DIN 3126 specification. Range of 25mm bits; Slotted, Phillips, Pozi, TRX-Star*, magnetic nut holders, stainless steel bit holder. Supplied in storage case.

Contents: Drill Bits; HSS Coated - Ø1.5, 2, 2.5, 3, 4, 5, 6mm, Masonry - Ø3, 4, 5, 6, 7, 8mm, Wood - Ø3, 4, 5, 6, 7, 8mm, 25mm Bits; Slotted - 4, 5, 6mm, Phillips - #1, #2, #3, Pozi - #1, #2, #3, TRX-Star* - T10, T20, T30, Magnetic Nut Holders; 6, 8, 10mm, Stainless Steel Bit Holder, Countersink Bit



D AK3717TCM
17pc HSS/Masonry Drill Bit Set

Set consists of 12 titanium nitride coated high-speed steel drills and five tungsten steel masonry drills. Popular range of sizes. Supplied in plastic storage box with rubberised, non-slip coating.

Contents: HSS; Ø1.5, 2, 2.5, 3, 3.2, 3.5, 4, 4.5, 4.8, 5, 5.5, 6mm, Masonry; Ø3, 5, 6, 8, 10mm



A

MM

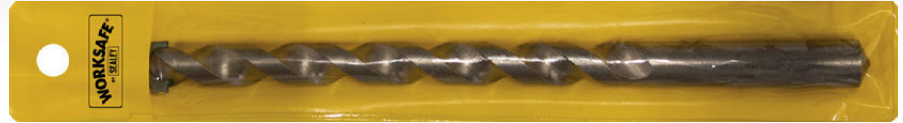

A SEE BELOW

Rotary Impact/Masonry Drill Bits

Ideal for general purpose drilling into most masonry materials. Supplied in a plastic wallet.

Model No:	Size:	Overall Length:
SS4X85	Ø4mm	85mm
SS45X85	Ø4.5mm	85mm
SS5X100	Ø5mm	100mm
SS5X150	Ø5mm	150mm
SS55X100	Ø5.5mm	100mm
SS55X150	Ø5.5mm	150mm
SS6X100	Ø6mm	100mm
SS6X150	Ø6mm	150mm
SS65X100	Ø6.5mm	100mm
SS65X150	Ø6.5mm	150mm
SS65X300	Ø6.5mm	300mm
SS7X100	Ø7mm	100mm
SS7X150	Ø7mm	150mm
SS7X300	Ø7mm	300mm
SS8X120	Ø8mm	120mm
SS8X150	Ø8mm	150mm

Model No:	Size:	Overall Length:
SS8X200	Ø8mm	200mm
SS8X250	Ø8mm	250mm
SS8X300	Ø8mm	300mm
SS8X400	Ø8mm	400mm
SS9X120	Ø9mm	120mm
SS10X150	Ø10mm	150mm
SS10X200	Ø10mm	200mm
SS10X300	Ø10mm	300mm
SS10X400	Ø10mm	400mm
SS10X600	Ø10mm	600mm
SS11X150	Ø11mm	150mm
SS11X300	Ø11mm	300mm
SS12X150	Ø12mm	150mm
SS12X200	Ø12mm	200mm
SS12X300	Ø12mm	300mm
SS12X400	Ø12mm	400mm

Model No:	Size:	Overall Length:
SS12X600	Ø12mm	600mm
SS13X150	Ø13mm	150mm
SS13X300	Ø13mm	300mm
SS13X400	Ø13mm	400mm
SS13X600	Ø13mm	600mm
SS14X150	Ø14mm	150mm
SS14X300	Ø14mm	300mm
SS14X400	Ø14mm	400mm
SS14X600	Ø14mm	600mm
SS15X400	Ø15mm	400mm
SS16X150	Ø16mm	150mm
SS16X300	Ø16mm	300mm
SS18X150	Ø18mm	150mm
SS18X300	Ø18mm	300mm
SS18X400	Ø18mm	400mm

B



C



D



E



F



G



H



H AK5708

8pc Tungsten Carbide Tipped Masonry Drill Bit Set

Tungsten carbide tipped for prolonged life and heavy-duty use. Shank features a special flute design for fast and effective waste removal. Set covers sizes from Ø3 to 10mm. Supplied in storage case.

Contents: Ø3, 4, 5.5, 6, 7, 8, 9, 10mm

B-G SEE BELOW

Chucks & Keys

Model No:	Description:
B DC003	10mm Keyless Drill Chuck - 3/8"-24UNF
B C3812K	10mm Keyless Drill Chuck - 1/2"-20UNF
B DC004	13mm Keyless Drill Chuck - 1/2"-20UNF
C DC005	13mm Keyless Drill Chuck Single Sleeve 1/2"-20UNF
D DC006	13mm Keyless Drill Chuck Auto Lock 1/2"-20UNF

Model No:	Description:
E DC001	10mm Drill Chuck & Key - 3/8"-24UNF
E DC002	13mm Drill Chuck & Key - 1/2"-20UNF
E C1212	13mm Chuck & Key - 1/2"-20UNF
F S2	10mm & 13mm S2 Chuck Key
F S3	16mm S3 Chuck Key
G DC/J-38K-L	10mm L-Shape Chuck Key

H





A WDCS

13pc SDS Plus Drill Bit & Chisel Set

Most popular sized SDS Plus drill bits included in one set. Professional quality steels for SDS Plus and Roto-Stop machines only. Supplied in sturdy storage case.

Contents: SDS Plus Drill Bits; Ø5.5 x 160, 6 x 160, 7 x 160, 8 x 210, 10 x 210, 10 x 260, 12 x 210, 12 x 260, 14 x 260mm, SDS Plus Chisels; Point, Gouge, Flat (20mm), Wide (40mm)



MM

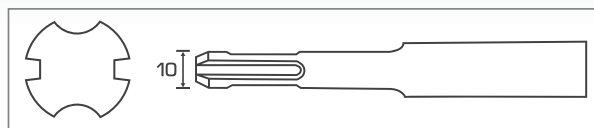

B SEE BELOW

SDS Plus Drill Bits

Model No:	Size:	Overall Length:
SDS4X110	Ø4mm	110mm
SDS4X160	Ø4mm	160mm
SDS5X110	Ø5mm	110mm
SDS5X160	Ø5mm	160mm
SDS5.5X110	Ø5.5mm	110mm
SDS5.5X160	Ø5.5mm	160mm
SDS5.5X210	Ø5.5mm	210mm
SDS6X110	Ø6mm	110mm
SDS6X160	Ø6mm	160mm
SDS6X210	Ø6mm	210mm
SDS6X260	Ø6mm	260mm
SDS6.5X110	Ø6.5mm	110mm
SDS6.5X160	Ø6.5mm	160mm
SDS6.5X210	Ø6.5mm	210mm
SDS6.5X260	Ø6.5mm	260mm
SDS7X110	Ø7mm	110mm
SDS7X160	Ø7mm	160mm
SDS7X210	Ø7mm	210mm
SDS8X110	Ø8mm	110mm
SDS8X160	Ø8mm	160mm
SDS8X210	Ø8mm	210mm
SDS8X260	Ø8mm	260mm
SDS8X310	Ø8mm	310mm
SDS8X450	Ø8mm	450mm
SDS10X110	Ø10mm	110mm
SDS10X160	Ø10mm	160mm
SDS10X260	Ø10mm	260mm
SDS10X310	Ø10mm	310mm
SDS10X360	Ø10mm	360mm
SDS10X450	Ø10mm	450mm
SDS10X600	Ø10mm	600mm
SDS10X1000	Ø10mm	1000mm

Supplied on a Hanging Tag.

Model No:	Size:	Overall Length:
SDS11X160	Ø11mm	160mm
SDS11X310	Ø11mm	310mm
SDS11X450	Ø11mm	450mm
SDS12X160	Ø12mm	160mm
SDS12X210	Ø12mm	210mm
SDS12X260	Ø12mm	260mm
SDS12X310	Ø12mm	310mm
SDS12X450	Ø12mm	450mm
SDS12X600	Ø12mm	600mm
SDS12X1000	Ø12mm	1000mm
SDS13X160	Ø13mm	160mm
SDS13X310	Ø13mm	310mm
SDS13X450	Ø13mm	450mm
SDS14X160	Ø14mm	160mm
SDS14X210	Ø14mm	210mm
SDS14X260	Ø14mm	260mm
SDS14X310	Ø14mm	310mm
SDS14X450	Ø14mm	450mm
SDS14X600	Ø14mm	600mm
SDS14X1000	Ø14mm	1000mm
SDS15X160	Ø15mm	160mm
SDS15X210	Ø15mm	210mm
SDS15X260	Ø15mm	260mm
SDS15X450	Ø15mm	450mm
SDS16X160	Ø16mm	160mm
SDS16X200	Ø16mm	200mm
SDS16X250	Ø16mm	250mm
SDS16X300	Ø16mm	300mm
SDS16X450	Ø16mm	450mm
SDS16X600	Ø16mm	600mm
SDS16X800	Ø16mm	800mm
SDS16X1000	Ø16mm	1000mm

Model No:	Size:	Overall Length:
SDS17X200	Ø17mm	200mm
SDS18X200	Ø18mm	200mm
SDS18X250	Ø18mm	250mm
SDS18X300	Ø18mm	300mm
SDS18X450	Ø18mm	450mm
SDS18X600	Ø18mm	600mm
SDS18X1000	Ø18mm	1000mm
SDS19X200	Ø19mm	200mm
SDS19X450	Ø19mm	450mm
SDS20X200	Ø20mm	200mm
SDS20X300	Ø20mm	300mm
SDS20X450	Ø20mm	450mm
SDS20X600	Ø20mm	600mm
SDS20X1000	Ø20mm	1000mm
SDS22X250	Ø22mm	250mm
SDS22X450	Ø22mm	450mm
SDS22X600	Ø22mm	600mm
SDS22X1000	Ø22mm	1000mm
SDS23X250	Ø23mm	250mm
SDS23X450	Ø23mm	450mm
SDS24X250	Ø24mm	250mm
SDS24X450	Ø24mm	450mm
SDS25X250	Ø25mm	250mm
SDS25X450	Ø25mm	450mm
SDS25X600	Ø25mm	600mm
SDS25X1000	Ø25mm	1000mm
SDS26X250	Ø26mm	250mm
SDS26X450	Ø26mm	450mm
SDS28X450	Ø28mm	450mm
SDS30X450	Ø30mm	450mm

A



Supplied on a Hanging Tag.

MM

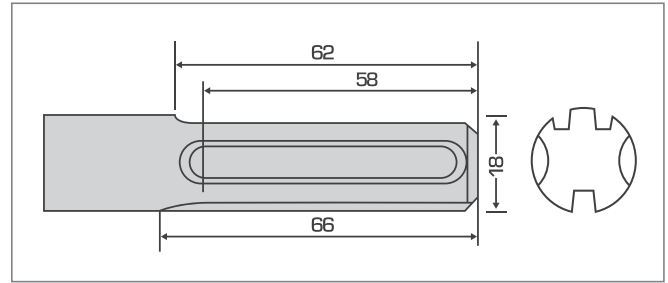

A SEE BELOW
SDS MAX Drill Bits

Model No:	Size:	Overall Length:
MAX12X340	Ø12mm	340mm
MAX12X540	Ø12mm	540mm
MAX13X340	Ø13mm	340mm
MAX13X540	Ø13mm	540mm
MAX14X340	Ø14mm	340mm
MAX14X540	Ø14mm	540mm
MAX15X340	Ø15mm	340mm
MAX15X540	Ø15mm	540mm
MAX16X340	Ø16mm	340mm
MAX16X540	Ø16mm	540mm
MAX16X920	Ø16mm	920mm
MAX18X340	Ø18mm	340mm
MAX18X540	Ø18mm	540mm
MAX18X940	Ø18mm	940mm
MAX19X340	Ø19mm	340mm
MAX19X540	Ø19mm	540mm
MAX20X320	Ø20mm	320mm
MAX20X520	Ø20mm	520mm
MAX20X920	Ø20mm	920mm
MAX22X320	Ø22mm	320mm
MAX22X520	Ø22mm	520mm

Model No:	Size:	Overall Length:
MAX22X920	Ø22mm	920mm
MAX24X320	Ø24mm	320mm
MAX24X520	Ø24mm	520mm
MAX25X320	Ø25mm	320mm
MAX25X520	Ø25mm	520mm
MAX25X920	Ø25mm	920mm
MAX25X1320	Ø25mm	1320mm
MAX26X340	Ø26mm	340mm
MAX26X520	Ø26mm	520mm
MAX28X370	Ø28mm	370mm
MAX28X570	Ø28mm	570mm
MAX30X370	Ø30mm	370mm
MAX30X570	Ø30mm	570mm
MAX32X370	Ø32mm	370mm
MAX32X570	Ø32mm	570mm
MAX32X920	Ø32mm	920mm

Model No:	Size:	Overall Length:
MAX32X1320	Ø32mm	1320mm
MAX35X370	Ø35mm	370mm
MAX35X570	Ø35mm	570mm
MAX38X370	Ø38mm	370mm
MAX38X570	Ø38mm	570mm
MAX40X370	Ø40mm	370mm
MAX40X570	Ø40mm	570mm
MAX40X920	Ø40mm	920mm
MAX40X1320	Ø40mm	1320mm

B



B 314C
5pc SDS MAX Demolition Kit

Five SDS MAX chisels supplied in a sturdy storage case.

Contents: Pointed Chisels; Ø18 x 280, 18 x 400mm, Flat Chisels; 24 x 280, 24 x 400, 50 x 360mm



Ear Defenders
For our full range of Ear Defenders, see page 1290.



C-F SEE BELOW
Adaptors

Model No:	Description:
C SDSADA	SDS Plus Adaptor
D B3K	Chuck Adaptor - SDS MAX to K Taper
E K1K	Chuck Adaptor - Kango 950 to K Taper
F B3S	Adaptor SDS MAX to SDS Plus



G SDSMAX40
Ø40mm SDS MAX
Rotary Hammer Drill 1500W/230V
For full details, see page 877.

A



25mm



50mm

A SEE BELOW

HSS M2 Rotabors

Manufactured from HSS M2 steel for fast and accurate hole drilling. Universal 19mm Weldon shank means these rotabors are suitable for use with Sealey and other leading brands of magnetic drills. Available in 25mm and 50mm cutting depths.

Model No:	Cut Depth:	Size:
RBHSS12S	25mm	Ø12mm
RBHSS13S	25mm	Ø13mm
RBHSS14S	25mm	Ø14mm
RBHSS15S	25mm	Ø15mm
RBHSS16S	25mm	Ø16mm
RBHSS17S	25mm	Ø17mm
RBHSS18S	25mm	Ø18mm
RBHSS19S	25mm	Ø19mm
RBHSS20S	25mm	Ø20mm
RBHSS21S	25mm	Ø21mm
RBHSS22S	25mm	Ø22mm
RBHSS23S	25mm	Ø23mm
RBHSS24S	25mm	Ø24mm
RBHSS25S	25mm	Ø25mm
RBHSS26S	25mm	Ø26mm
RBHSS27S	25mm	Ø27mm
RBHSS28S	25mm	Ø28mm
RBHSS29S	25mm	Ø29mm
RBHSS30S	25mm	Ø30mm
RBHSS31S	25mm	Ø31mm
RBHSS32S	25mm	Ø32mm
RBHSS33S	25mm	Ø33mm
RBHSS34S	25mm	Ø34mm
RBHSS35S	25mm	Ø35mm
RBHSS36S	25mm	Ø36mm
RBHSS37S	25mm	Ø37mm

*RSBP Pilot Drills Only

Model No:	Cut Depth:	Size:
RBHSS38S	25mm	Ø38mm
RBHSS39S	25mm	Ø39mm
RBHSS40S	25mm	Ø40mm
RBHSS41S	25mm	Ø41mm
RBHSS42S	25mm	Ø42mm
RBHSS43S	25mm	Ø43mm
RBHSS44S	25mm	Ø44mm
RBHSS45S	25mm	Ø45mm
RBHSS46S	25mm	Ø46mm
RBHSS47S	25mm	Ø47mm
RBHSS48S	25mm	Ø48mm
RBHSS49S	25mm	Ø49mm
RBHSS50S	25mm	Ø50mm
RBHSS51S	25mm	Ø51mm
RBHSS12L	50mm	Ø12mm
RBHSS13L*	50mm	Ø13mm
RBHSS14L*	50mm	Ø14mm
RBHSS15L	50mm	Ø15mm
RBHSS16L	50mm	Ø16mm
RBHSS17L	50mm	Ø17mm
RBHSS18L	50mm	Ø18mm
RBHSS19L	50mm	Ø19mm
RBHSS20L	50mm	Ø20mm
RBHSS21L	50mm	Ø21mm
RBHSS22L	50mm	Ø22mm
RBHSS23L	50mm	Ø23mm
RBHSS24L	50mm	Ø24mm

B



B SEE BELOW

Pilot Rods

Available in two sizes, RBSP suitable for 25mm cut Rotabors and WRBLP suitable for 50mm cut Rotabors.

Model No:	Description:	Length:
RBSP	Short Straight Pin	77mm
WRBLP	Long Straight Pin	102mm

Model No:	Cut Depth:	Size:
RBHSS25L	50mm	Ø25mm
RBHSS26L	50mm	Ø26mm
RBHSS27L	50mm	Ø27mm
RBHSS28L	50mm	Ø28mm
RBHSS29L	50mm	Ø29mm
RBHSS30L	50mm	Ø30mm
RBHSS31L	50mm	Ø31mm
RBHSS32L	50mm	Ø32mm
RBHSS33L	50mm	Ø33mm
RBHSS34L	50mm	Ø34mm
RBHSS35L	50mm	Ø35mm
RBHSS36L	50mm	Ø36mm
RBHSS37L	50mm	Ø37mm
RBHSS38L	50mm	Ø38mm
RBHSS39L	50mm	Ø39mm
RBHSS40L	50mm	Ø40mm
RBHSS41L	50mm	Ø41mm
RBHSS42L	50mm	Ø42mm
RBHSS43L	50mm	Ø43mm
RBHSS44L	50mm	Ø44mm
RBHSS45L	50mm	Ø45mm
RBHSS46L	50mm	Ø46mm
RBHSS47L	50mm	Ø47mm
RBHSS48L	50mm	Ø48mm
RBHSS49L	50mm	Ø49mm
RBHSS50L	50mm	Ø50mm
RBHSS51L	50mm	Ø51mm



C

110V

HEAVY DUTY



Control Panel

C MAG60110VHD

60mm Heavy-Duty Magnetic Drilling Machine 110V

Manufactured using high quality components for performance and reliability. Made from heavy-duty die-cast magnesium alloy with a variable speed gearbox for greater accuracy. Fitted with a powerful magnet to ensure unit stays adhered at any angle and a double dovetail groove to increase the stroke length. Includes safety fixing strap and integrated coolant system to extend the life of cutters and increase the quality of the cut. Can be used with a 16mm twist drill chuck and M8 to M20 Tapping chucks. Designed for use in fabrication, construction and other applications when drilling/tapping ferrous metal.

D

230V



D MAG35230VLP

35mm Low Profile Magnetic Drilling Machine 230V

Manufactured using high quality components for performance and reliability. Lightweight and compact unit made with a low profile for those difficult to get to places. Fitted with a powerful magnet to ensure unit stays adhered at any angle. Includes safety fixing strap. Designed for use in fabrication, construction and other applications when drilling ferrous metal.



A WDCKIT5
Diamond 5 Core Kit

Contents: Diamond Cores; Ø38, Ø52, Ø65, Ø117, Ø127mm, SDS Plus Adaptors; 100, 300mm, Hex Adaptors; Ø13mm - 100, 300mm, 10mm 'A-Taper' Pilot, Extractor Drift



B SEE BELOW
Core-to-Go Dry Diamond Core Drill Bits

Best results when used with a purpose-built core drilling machine. SDS machines can be used but the drilling speed and diamond core life will be greatly reduced. Suitable for fast and accurate drilling of holes through concrete, masonry and brickwork. Each core supplied with hex drive adaptor, pilot drill and extractor drift (excludes CTG22 & CTG28).

Model No:	Size:	Length:
CTG22	Ø22mm	300mm
CTG28	Ø28mm	300mm
CTG32	Ø32mm	150mm
CTG38	Ø38mm	150mm
CTG48	Ø48mm	150mm
CTG52	Ø52mm	150mm
CTG65	Ø65mm	150mm
CTG78	Ø78mm	150mm
CTG107	Ø107mm	150mm
CTG117	Ø117mm	150mm
CTG127	Ø127mm	150mm
CTG150	Ø150mm	150mm



E DDP
200mm Pilot Drill



D DDD
Drift Key
For removal of guide rod or taper drill from the adaptor.



G DDAH
Hex Standard Adaptor Pack
Includes drift key and pilot rod.



F DDAS
SDS Plus Standard Adaptor Pack
Includes drift key and pilot rod.



H DDAHL
310mm Hex Adaptor Pack
Includes drift key and pilot rod.



I DDASL
310mm SDS Plus Adaptor Pack
Includes drift key and pilot rod.

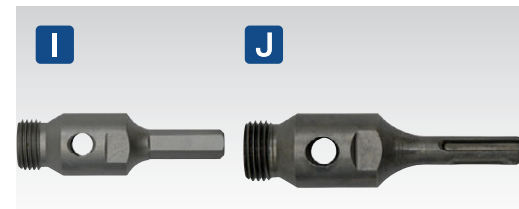

I-J SEE BELOW
Standard Adaptors

Model No:	Description:
I DDAHO	100mm Hex Standard Adaptor
J DDASO	100mm SDS Plus Standard Adaptor

K DDA250EX
250mm Extension Rod
250mm Threaded 1/2" BSP extension bar with taper for pilot rod/drill.

A-E SEE BELOW

Hex Diamond Drill Bits

Vacuum brazed diamond drill bits. Hex shank for use with drills. Fast dry drilling in to porcelain tiles.

Model No:	Size:
A DBD6H	Ø6mm
B DBD7H	Ø7mm
C DBD8H	Ø8mm
D DBD10H	Ø10mm
E DBD12H	Ø12mm



G DB01 Deburring Tool with Spare Blade

Composite handgrip with interchangeable swivel cutting bits. Spare cutter stored in handle. Suitable for deburring pipes and sheet materials.

Length: 150mm



H SEE BELOW Pilot Drills

Suitable for use with hole saw arbors.

Model No:	Application:	Length:
HKPD75	HKA1430	75mm
HKPD105	HKA32152	105mm

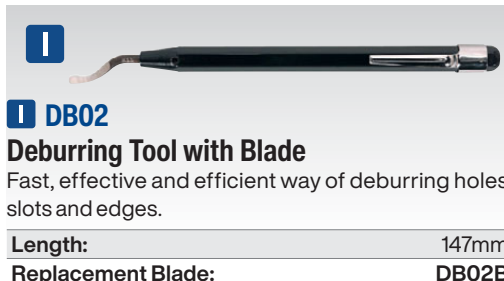

I DB02 Deburring Tool with Blade

Fast, effective and efficient way of deburring holes, slots and edges.

Length: 147mm

Replacement Blade: DB02B

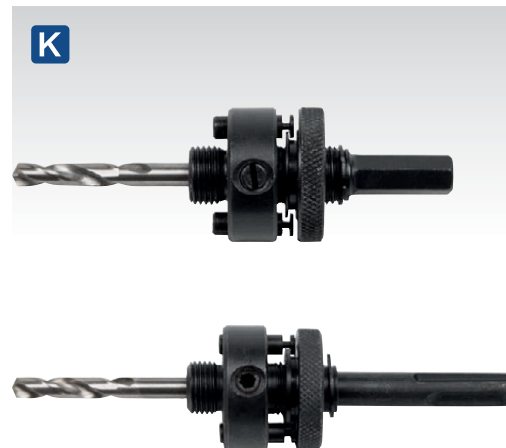

K SEE BELOW Arbor with Pilot Drill

Model No:	Description:
WHSHL	Ø32-152mm Hex Mandrel
WHSSL	Ø32-152mm SDS Plus Mandrel
WHSSS	Ø14-30mm SDS Plus Mandrel



F CP20VDDKIT1 2Ah Ø13mm Combi Drill/Driver Kit

For full details, see page 847.

Contents:
CP20VDD - Combi Drill/Driver
CP20VBP2 - 2Ah Battery
CP20VMC - Battery Charger
CP1200CB - Canvas Storage Bag

J SR701 100 x 600mm Hex Shank Mixer Paddle

Designed to combine liquids so they're ready for use. The paddle mixer works great for paint, slurry, plaster, adhesives and textured coatings. Constructed using carbon steel with an electroplated finish. Fix the mixer into the chuck on your drill, tighten and you are ready to go. For an easy storage solution, use the rubber hanger supplied with the paddle mixer.





A SEE BELOW

Individual Hole Saws

Manufactured from Bi-Metal M3 steel with milled teeth for fast accurate cuts and long-life.

Model No:	Size:
WHS16	Ø16mm
WHS19	Ø19mm
WHS20	Ø20mm
WHS22	Ø22mm
WHS25	Ø25mm
WHS29	Ø29mm
WHS32	Ø32mm
WHS35	Ø35mm
WHS38	Ø38mm
WHS40	Ø40mm
WHS44	Ø44mm
WHS51	Ø51mm
WHS57	Ø57mm
WHS64	Ø64mm
WHS70	Ø70mm
WHS76	Ø76mm
WHS79	Ø79mm
WHS83	Ø83mm
WHS92	Ø92mm
WHS102	Ø102mm
WHS114	Ø114mm
WHS127	Ø127mm
WHS152	Ø152mm



B WSPHSK

9pc Plumber's Hole Saw Kit

Bi-metal blades. Professional quality kit in metal storage case.

Contents: Hole Saws (1 of each); Ø19, 22, 29, 38, 44, 57mm; Simple Arbor (x1), Quick Release Arbor (x1), Adaptor (x1)



C WSEHSK

9pc Electrician's Hole Saw Kit

Bi-metal blades. Professional quality kit in metal storage case.

Contents: Hole Saws (1 of each); Ø16, 20, 25, 32, 40, 51mm; Simple Arbor (x1), Quick Release Arbor (x1), Adaptor (x1)



D WDLK

9pc Downlight Hole Saw Kit

Fits most common sizes of downlights.

Contents: Hole Saws; Ø51, 60, 65, 72, 75 86mm, Mandrel and Pilot Drive, Hex Key



E SEE RIGHT

Electroplated Diamond Hole Saws

Electroplated diamond coated hole saws with a diamond coated cutting edge that allows precise chip-free cutting of glass, granite, marble and ceramics. Integrated water-cooling sponge that prolongs the life of the cutting edge by reducing heat build-up. Sponge must be soaked in water before use. Multiple cutting depths and diameter ranges makes these hole saws ideal for plumbing and electrical installations. Rounded 10mm hex shank means they will fit both handheld and pillar drill chucks.

Model No:	Cutting Depth:	Size:
DHS18	45mm	Ø18mm
DHS20	45mm	Ø20mm
DHS22	45mm	Ø22mm
DHS25	45mm	Ø25mm
DHS30	45mm	Ø30mm
DHS45	45mm	Ø45mm
DHS60	45mm	Ø60mm

A-G SEE BELOW

SDS Plus Breaker Steels



Supplied on Hanging Tag.

Breaker Steels
 We stock a wide range of breaker steels and chisels to cover all types of applications across 18 types of fittings. These heavy-duty breakers and chisels are perfect for use with concrete, demolition work, render removal, chasing and many other different tasks.

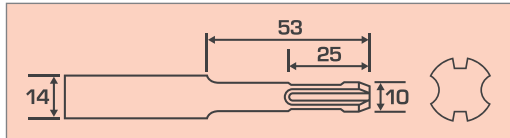

A SEE BELOW
250mm Chisels - SDS Plus

Fits most SDS Plus Roto-Stop Hammer Drills.

Model No:	Length:	Width:
D1CH	250mm	20mm
D1WC	250mm	40mm



B D75W
75 x 165mm Wide Chisel - SDS Plus

Wide SDS Plus chisel. Fits most SDS Plus Roto-Stop Hammer Drills. Ideal for use on concrete and masonry. Suitable for the quick and easy removal of tiles, chipping and chiselling as well as breaking through and light demolition work.

Length:	165mm
Width:	75mm



Ideal for lifting tiles

C SEE BELOW
Wide Cranked Chisels - SDS Plus

Fits most SDS Plus Roto-Stop Hammer Drills. Ideal for lifting tiles.

Model No:	Length:	Width:
D2WC	250mm	40mm
D75WC	165mm	75mm



D D1G
25 x 250mm Gouge Chisel - SDS Plus

Fits most SDS Plus Roto-Stop Hammer Drills.

Length:	250mm
Width:	25mm



E D1PT
250mm Point - SDS Plus

Fits most SDS Plus Roto-Stop Hammer Drills.

Length:	250mm
---------	-------

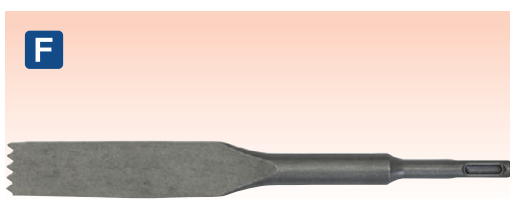

F D1CC
30 x 250mm Toothed Mortar/Comb Chisel SDS Plus

Length:	250mm
Width:	30mm



G WDCS
13pc SDS Plus Drill Bit & Chisel Set

Most popular sized SDS Plus drill bits included in one set. Professional quality steels for SDS Plus and Roto-Stop machines only. Supplied in sturdy storage case.

Contents:	SDS Plus Drill Bits; Ø5.5 x 160, 6 x 160, 7 x 160, 8 x 210, 10 x 210, 10 x 260, 12 x 210, 12 x 260, 14 x 260mm, SDS Plus Chisels; Point, Gouge, Flat (20mm), Wide (40mm)
-----------	--



A-I SEE BELOW
SDS MAX Breaker Steels

SDS MAX breakers are more powerful than SDS Plus drills and require heavy-duty points and chisels. This range is suited for chipping and chiselling tiles, mortar and other heavy-duty materials, such as brick and concrete.



Supplied on Hanging Tag.

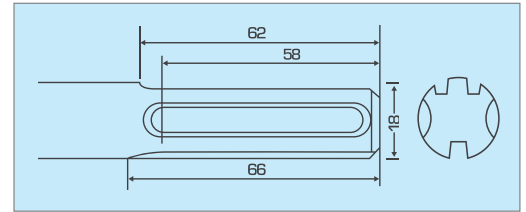

A



A SEE BELOW
Points - SDS MAX

Model No:	Length:
X1PT	300mm
X2PT	400mm
X3PT	450mm
X4PT	600mm

B



B SEE BELOW
Chisels - SDS MAX

Model No:	Length:	Width:
X1CH	300mm	25mm
X2CH	400mm	20mm
X3CH	450mm	25mm
X4CH	600mm	20mm

C



C SEE BELOW
Wide Chisels - SDS MAX

Model No:	Length:	Width:
X1WC	400mm	50mm
X2WC	400mm	75mm
X3WC	350mm	112mm
X3WCB NEW	445mm	112mm
X4WCB NEW	600mm	75mm

D



D X1CS
110 x 455mm Clay Spade - SDS MAX

Length:	455mm
Width:	110mm

E



E X4WC
75 x 300mm Wide Cranked Chisel SDS MAX

Wide chisel is cranked making it perfect for lifting tiles and stone.

Length:	300mm
Width:	75mm



Model No. X4WC wide chisel is cranked making it perfect for lifting tiles and stone.

F



F X1CC
30 x 290mm Scutch Comb Chisel SDS MAX

Length:	290mm
Width:	30mm

G



G X1SH
400mm Stem - SDS MAX

Length:	400mm
Width:	Tapered

H



H X1G
18 x 450mm Hollow Gouge - SDS MAX

Length:	450mm
Width:	18mm

I



I 314C
5pc SDS MAX Demolition Kit

Five SDS MAX chisels supplied in a sturdy storage case.

Contents: Pointed Chisels; Ø18 x 280, 18 x 400mm, Flat Chisels; 24 x 280, 24 x 400, 50 x 360mm

J

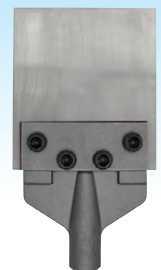

J K2FC
Floor Scraper (M12 Bolt)

For use with Stem Model No. X1SH. Replacement parts available; Model No. K2SB Blade, Model No. K2BN Nut & Bolt.

K



K 9142L
Anti-Vibration Gloves Large - Pair

For full details, see page 1287.



Safety Goggles
For our full range of Safety Goggles, see pages 1277 to 1279.

A NEW**A IE1EWC****110 x 608mm Extra Wide Chisel - 1-1/8"Hex**

Also fits; Wacker - BH22, 23, EH22, 23, 24, BHF30S.

Length:	608mm
Width:	110mm

F-I SEE BELOW**Hilti TP805/TE905/TE1000****F****F G1PT****500mm Point - Hilti TP805/TE905/TE1000**

Length:	500mm
---------	-------

G**G G1CH****30 x 500mm Chisel - Hilti TP805/TE905/TE1000**

Length:	500mm
Width:	30mm

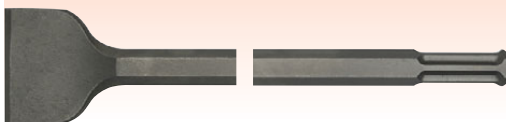
H**H G2WC****80 x 500mm Wide Chisel - Hilti TP805/TE905/TE1000**

Length:	500mm
Width:	80mm

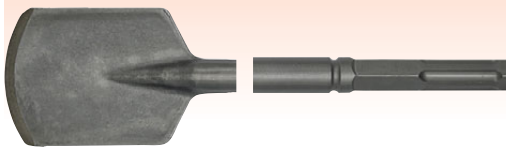
I**I G1CS****110 x 520mm Clay Spade - Hilti TP805/TE905/TE1000**

Length:	520mm
Width:	110mm

B-E SEE BELOW**1-1/4" Hexagonal****B****B Q1PT****620mm Point - 1-1/4"Hex**

Length:	620mm
---------	-------

D**D Q1AC****125 x 560mm Asphalt Cutter - 1-1/4"Hex**

Length:	560mm
Width:	125mm

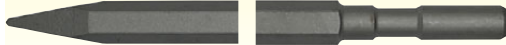
J-L SEE BELOW**CP9****J****J P1PT****610mm Point - CP9**

Length:	610mm
---------	-------

K**K P1CH****25 x 250mm Chisel - CP9**

Also fits; VP9, RK4, DKR34, 21TEC, 3300 Ball Type (Gold).

Length:	250mm
Width:	25mm

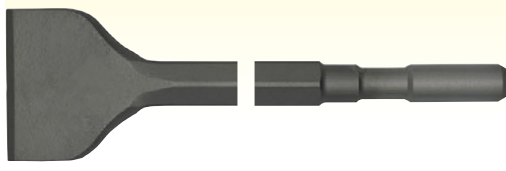
L**L P3WC****75 x 300mm Chisel - CP9**

Also fits; VP9, RK4, DKR34, 21TEC, 3300 Ball Type (Gold).

Length:	300mm
Width:	75mm

C**C SEE BELOW****Chisels - 1-1/4"Hex**

Model No:	Length:	Width:
Q1CH	620mm	35mm
Q1WCH	620mm	75mm

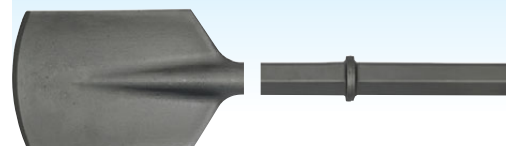
E**E Q1CS****140 x 570mm Clay Spade - 1-1/4"Hex**

Length:	570mm
Width:	140mm

M NEW**M 71EWC****125 x 475mm Extra-Wide Chisel - 7/8"Hex**

Length:	475mm
Width:	125mm

N-O SEE BELOW**Makita HM0810****N****N M2CH****20 x 450mm Chisel - Makita HM0810**

Length:	450mm
Width:	20mm

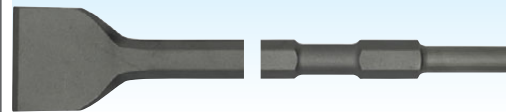
O**O M1WC****50 x 450mm Wide Chisel - Makita HM0810**

Length:	450mm
Width:	50mm

A-E SEE BELOW AND RIGHT
Kango 900

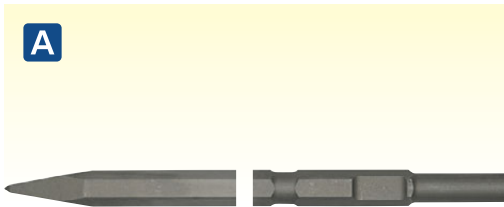
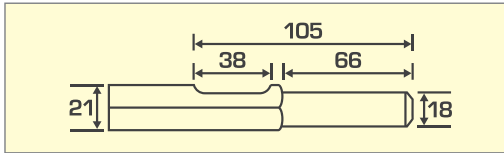

A SEE BELOW
Points - Kango 900

Model No:	Length:
K1PT	375mm
K2PT	450mm
K3PT	600mm

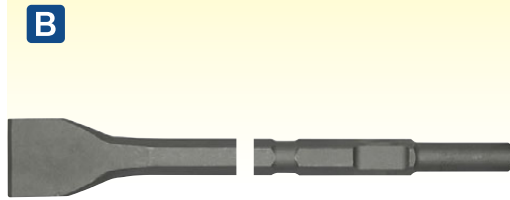

B SEE BELOW
Wide Chisels - Kango 900

Model No:	Length:	Width:
K1WC	300mm	50mm
K2WC	300mm	75mm



D SEE BELOW
Chisels - Kango 900

Model No:	Length:	Width:
K1CH	375mm	35mm
K2CH	450mm	35mm
K3CH	600mm	35mm

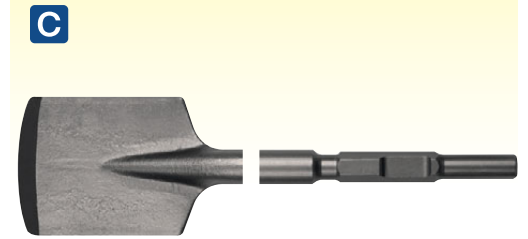

C K1CS
110 x 460mm Clay Spade - Kango 900

Length:	460mm
Width:	110mm



E K1SH
280mm Stem (Locked) - Kango 900

Length:	280mm
Width:	Tapered

F-G SEE RIGHT
Kango 637

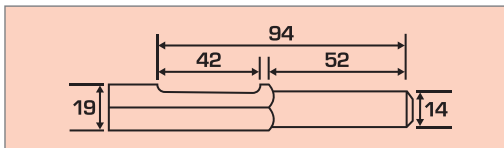

F A1PT
380mm Point - Kango 637

Length:	380mm
---------	-------



G SEE BELOW
Chisels - Kango 637

Model No:	Length:	Width:
A1CH	380mm	25mm
A2CH	450mm	25mm

H-L SEE BELOW AND RIGHT
Bosch 11304

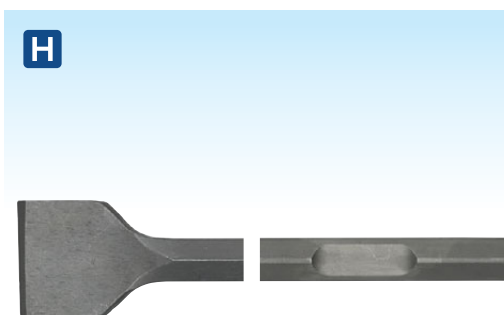
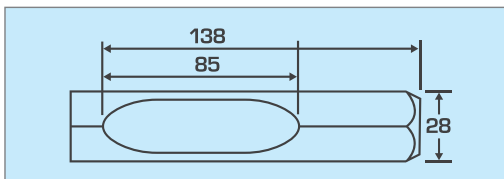

H B1WC
75 x 375mm Wide Chisel - Bosch 11304

Length:	375mm
Width:	75mm



I SEE BELOW
Points - Bosch 11304

Model No:	Length:
B1PT	375mm
B2PT	450mm



J SEE BELOW
Chisels - Bosch 11304

Model No:	Length:	Width:
B1CH	375mm	30mm
B2CH	450mm	30mm

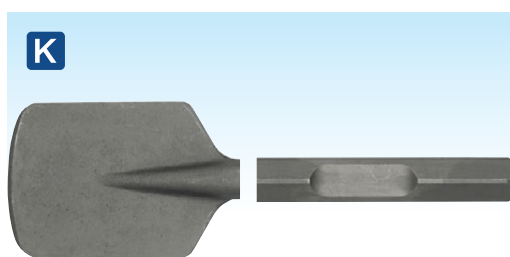

K B1CS
110 x 500mm Clay Spade - Bosch 11304

Length:	500mm
Width:	110mm

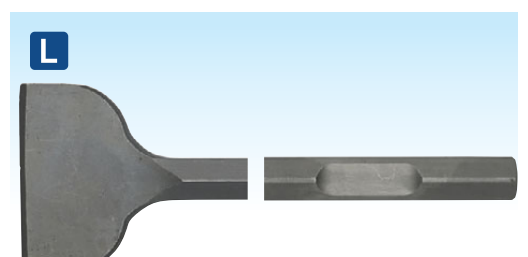

L B1AC
130 x 500mm Asphalt Cutter - Bosch 11304

Length:	500mm
Width:	130mm

SEGMENTED BLADES

The slots on segmented blades help to improve the flow of air to the blade, which in turn keeps the temperature down and increases the life of the blade. There are various types of shapes and sizes of segments, which lend themselves to the cutting of different materials.

TURBO BLADES

With their continuous rim and serrated edge, these blades are intended to give faster cutting speeds, yet still maintaining a smooth cut. These blades are suitable for normal angle grinders and circular saws and are designed to cut through the toughest of materials.

HOT PRESSED

Hot Pressed

These diamond discs have an extra process in their manufacturing cycle to help improve their hardness. These discs cost slightly more, but have a longer lifespan than standard, cold pressed discs.

LASER WELDED

Laser Welded

Laser welded discs are designed to withstand higher temperatures, which in turn improves the life of the disc and also allows for cutting of harder materials without any issues. Laser welded segments are also generally larger and therefore last longer.

SEGMENT LENGTH

Segment Length

When comparing quality levels of diamond disc, it is always important to check the segment length. Generally, the larger the segment length, the more cutting life the disc will have.

ADVANTAGES

Advantages of Diamond Blades

Diamond blades create a cleaner cut than standard cutting discs and are safer to use. They are longer lasting and therefore more economical over time.

A



A SEE BELOW

Value Diamond Blades

Suitable for cutting most types of building materials. For best results avoid extremely hard or abrasive materials. 7mm Segments.

Model No:	Diameter:	Bore:
WDV115	Ø115mm	Ø22mm
WDV230	Ø230mm	Ø22mm
WDV300/20	Ø300mm	Ø20mm

B



B SEE BELOW

Silver Easy Cut Diamond Blades

Suitable for cutting most types of building materials. 10mm Segments.

Model No:	Diameter:	Bore:
WDEC115	Ø115mm	Ø22mm
WDEC300/20	Ø300mm	Ø20mm

C SEE BELOW

Value Plus Diamond Blades

Value Plus blades suitable for cutting hard and medium materials including concrete, brick and stone. 10mm Segments.

Model No:	Diameter:	Bore:
WDVP100	Ø100mm	Ø16mm
WDVP115	Ø115mm	Ø22mm
WDVP125	Ø125mm	Ø22mm
WDVP230	Ø230mm	Ø22mm
WDVP300/20	Ø300mm	Ø20mm
WDVP300/78	Ø300mm	Ø22mm

C



DIAMOND BLADE CUTTING GUIDE

	Light Masonry	Concrete	Stone	Reinforced Concrete	Steel	Cast Iron	Mortar	Asphalt Tarmac	Hard Masonry
WDV	✓	✓	✗	✗	✗	✗	✗	✗	✗
WDVP	✓	✓	✓	✗	✗	✗	✗	✗	✗
WDEC	✓	✓	✓	✗	✗	✗	✗	✗	✗
WDC	✓	✓	✓	✗	✗	✗	✗	✗	✗
WDMP	✓	✓	✓	✓	✗	✗	✗	✗	✓
WDTA	✓	✓	✓	✓	✓	✓	✗	✗	✗
WDPA	✓	✓	✓	✓	✓	✓	✗	✗	✗
WDEC/MR	✓	✗	✗	✗	✗	✗	✓	✗	✗
WDVM	✓	✓	✓	✓	✗	✗	✗	✓	✗
WDT	✓	✓	✓	✓	✗	✗	✗	✓	✗
WDHFS	✓	✓	✓	✓	✗	✗	✗	✗	✓
WDH	✓	✓	✓	✓	✗	✗	✗	✗	✓
WDA	✓	✓	✓	✓	✗	✗	✗	✗	✓



HOT PRESSED

A SEE BELOW

Multipurpose Cutting Diamond Blades

Suitable for cutting various building materials such as granite, masonry, concrete and hard bricks. Can be used for wet or dry cutting. 15mm Diamond segments allow for longer use per disc.

Model No:	Diameter:	Bore:
WDMP115	Ø115mm	Ø22mm
WDMP230	Ø230mm	Ø22mm
WDMP300/20	Ø300mm	Ø20mm
WDMP350/22	Ø350mm	Ø22mm



HOT PRESSED

B SEE BELOW

Turbo Allmat Diamond Blades

Cuts through the toughest of materials including reinforced concrete, steel and cast iron. Hot pressed 10mm segments.

Model No:	Diameter:	Bore:
WDTA115	Ø115mm	Ø22mm
WDTA230	Ø230mm	Ø22mm
WDTA300	Ø300mm	Ø20mm

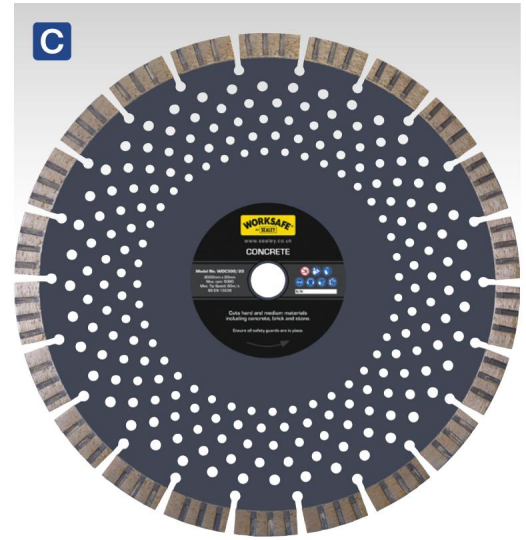

C SEE BELOW

Concrete Diamond Blades

Ideal for cutting concrete. Cold pressed sintering allows the blade to be more durable. Can be used for dry cutting. 15mm Diamond segments allow for longer use per blade.

Model No:	Diameter:	Bore:
WDC115	Ø115mm	Ø22mm
WDC230	Ø230mm	Ø22mm
WDC300/20	Ø300mm	Ø20mm

Models A & B are suitable for cutting a large range of commonly found materials, meaning less blade changes.



LASER WELDED

D SEE BELOW

Platinum Allmat Diamond Blades

Will cut through the toughest of materials; reinforced concrete, steel and cast iron. Laser welded 10mm segments.

Model No:	Diameter:	Bore:
WDPA125	Ø125mm	Ø22mm
WDPA350/20	Ø350mm	Ø20mm
WDPA350/25	Ø350mm	Ø25mm



6.4mm Thick

E WDEC1156MR

Ø115 x Ø22mm Easy Cut Diamond Blade Mortar Raker

Ideal for the removal of standard mortar from brickwork.

Diameter:	Ø115mm
Bore:	Ø22mm



F SEE BELOW

Anti-Vibration Gloves - Pair

Special anti-vibration material covers palm and fingertips to significantly reduce the effects of impact and vibration. Breathable fabric improves comfort. Ideal for use with jack hammers, air impact tools, drilling equipment and chainsaws, among others. Conforms to EN 388:2016 and EN ISO 10819:2013.

Model No:	Size:	Pack Qty:
9142L	Large	1
9142XL	X-Large	1



G SSP18F

Ear Defenders Folding

Lightweight, yet rugged construction, certified to BS EN 352-1:2002 standard. Hearing protection level in excess of the standard, with an SNR of 30.4dB. Adjustable swivel cups for optimum comfort and safety. Arms fold in for easy storage. Fully approved to protect against high noise levels in most working environments.

**A DST14****14L Dust Suppression Water Tank**

Dust suppression tank with 14L working capacity. Effective at suppressing dust while using cut-off saws, bench saws and floor saws in all working environments. Automatic pressure release valve stops pressure building higher than 3bar for optimum use. Before use 20 full pumps will allow for 1-1½ minutes of operation. Includes attached strap for easy transportation, a 3m hose with quick release coupling and a spare set of washers.

**LASER WELDED****D SEE BELOW****Floor Saw Diamond Blades - Hard**

Laser welded 10mm segments for premium quality. For use with a floor saw on hard materials.

Model No:	Diameter:	Bore:
WDHFS350	Ø350mm	Ø25mm
WDHFS450	Ø450mm	Ø25mm

**B WDV300/20****Ø300 x Ø20mm Valuemac Diamond Blade**

Suitable for dry-cutting very abrasive materials including asphalt and tarmac.

Diameter:	Ø300mm
Bore:	Ø20mm

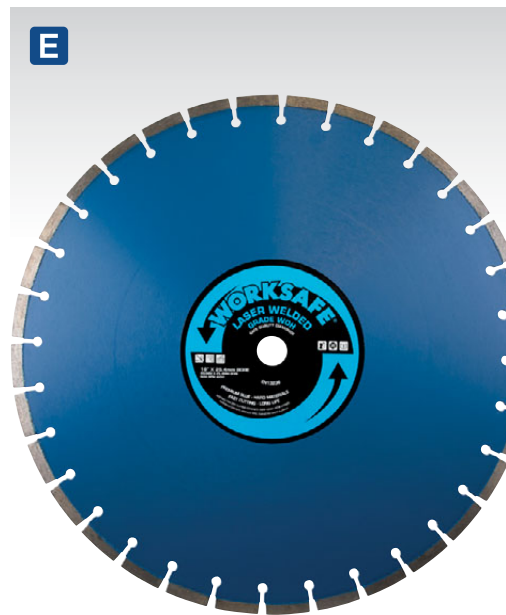
**LASER WELDED****E WDH450****Ø450 x 25mm Premium Blue WDH Diamond Blade**

Suitable for cutting hard materials including concrete with flint, engineering bricks, hard facing bricks, hard concrete kerbs and slabs, lintels, clay paviours and pipes, Portland stone, York stone and most hard materials.

Diameter:	Ø450mm
Bore:	Ø25mm

It is recommended to 'wet' cut with any diamond blade above 230mm. This prevents excess dust whilst cutting and helps to keep the temperature of the blade down, prolonging its life.

**LASER WELDED****C SEE BELOW****Asphalt/Tarmac Diamond Blades**

Special diamond segments configured for improved cutting and wear rate. Suitable for dry-cutting of very abrasive materials, including asphalt and tarmac.

Model No:	Diameter:	Bore:
WDT230	Ø230mm	Ø22mm
WDT300/20	Ø300mm	Ø20mm
WDT350	Ø350mm	Ø25mm
WDT450	Ø450mm	Ø25mm

**LASER WELDED****F SEE BELOW****Premium Blue WDA Diamond Blades**

Suitable for cutting abrasive materials including concrete blocks. Concrete paviours, sandstone, arc block, limestone, green concrete, concrete roof tiles and breeze blocks. Laser welded 10mm segments.

Model No:	Diameter:	Bore:
WDA230	Ø230mm	Ø22mm
WDA300/20	Ø300mm	Ø20mm
WDA300/22	Ø300mm	Ø22mm
WDA350	Ø350mm	Ø25mm
WDA450	Ø450mm	Ø25mm



A WDCUP105

Diamond Cup Grinding Disc

Ideal for the smooth grinding of stone, concrete and stock removal. Suitable for Sealey and most other brands of Ø115/125mm angle grinders.

Imperial:	Ø4"
Metric:	Ø105mm
Bore:	Ø22mm



B-C SEE BELOW

Turbo Row Concrete Grinding Heads

Ideal for grinding stone and concrete. Turbo row segments allow for a continuous cut, therefore a faster cutting speed while also giving a smoother finish. Cold pressed, sintered head allows it to be more durable.

Model No:	Diameter:	Bore:
B WDRTCUP115	Ø115mm	Ø22mm
C WDRTCUP125	Ø125mm	Ø22mm

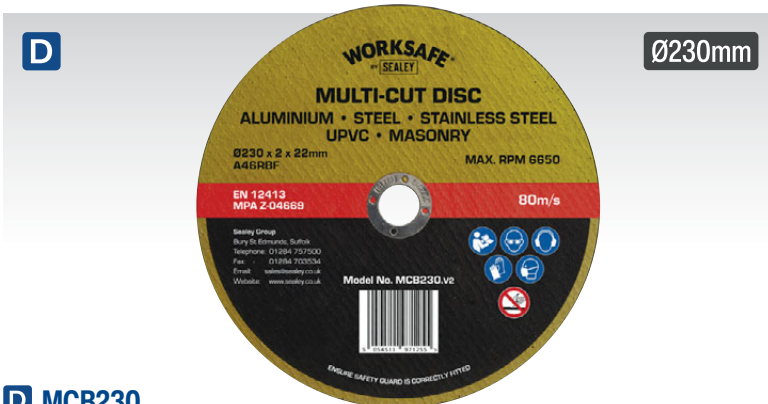

D MCB230

Ø230 x 2 x Ø22mm Multi-Cut Disc

Multipurpose cutting disc. Suitable for cutting mild steel, stainless steel (inox), UPVC, aluminium and masonry. Eliminates the need to change disc for different applications.

Disc Size :	Ø230mm(Ø9")
Bore:	Ø22mm

Multi-Cutting Discs
Our multi-material cutting discs are designed to cut through five different materials, saving you the effort of constantly having to change discs during a job. These discs also save you having to keep multiple disc types as they can cut most materials that would be required on a day-to-day basis.

Steel

Brick

Aluminium

UPVC

INOX



F SEE BELOW

Metal Grinding Discs

Depressed centre metal grinding discs.

Model No:	Disc Size Metric:	Disc Size Imperial:	Bore:	Pack Qty:
PTC/50G	Ø58 x 4mm	Ø2-1/2"	Ø9.5mm	1
PTC/100G	Ø100 x 6mm	Ø4"	Ø16mm	1
PTC/115G	Ø115 x 6mm	Ø4.5"	Ø22mm	1
PTC/115G5	Ø115 x 6mm	Ø4.5"	Ø22mm	5
PTC115G12 NEW	Ø115 x 6mm	Ø4.5"	Ø22mm	12
PTC/125G	Ø125 x 6mm	Ø5"	Ø22mm	1
PTC/230G	Ø230 x 6mm	Ø9"	Ø22mm	1



E PTC/115MC

Universal Cutting Disc

Multipurpose cutting disc. Suitable for cutting mild steel, stainless steel (inox), UPVC, aluminium and masonry. Eliminates the need to change disc for different applications.

Disc Size :	Ø115 x 1.6mm
Bore:	Ø22.2mm



G NEW

Ø300mm

G PTC/30020C

Ø300 x 3.2 x Ø20mm Bore Flat Metal Cutting Disc

General-purpose flat metal cutting discs. Recommended for use with Sealey and other leading makes of grinding and cutting power tools.

Disc Size:	Ø300mm(12") x 3.2mm
Bore:	Ø20mm

A

Ø3" Ø4" Ø4½"
 Ø5" Ø6" Ø9"
 Ø12" Ø14"

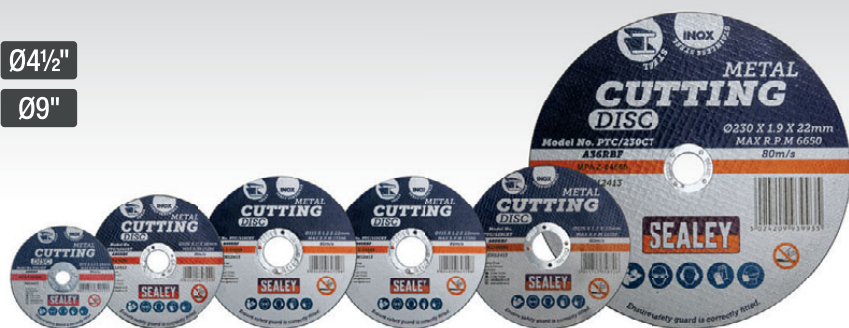

Bulk packs available on some models, see below.

A SEE BELOW

Metal Cutting Discs

Model No's ending CT and CET are also suitable for cutting stainless steel.

Model No:	Disc Size Metric:	Disc Size Imperial:	Material:	Bore:	Pack Quantity:	
PTC/3C	Ø75 x 2mm	Ø3"	Steel	Ø10mm	1	
PTC/3C5	Ø75 x 2mm	Ø3"	Steel	Ø10mm	5	
PTC/3C100	NEW	Ø75 x 2mm	Ø3"	Steel	Ø10mm	100
PTC/100C	Ø100 x 3mm	Ø4"	Steel	Ø16mm	1	
PTC/100C50	NEW	Ø100 x 3mm	Ø4"	Steel	Ø16mm	50
PTC/115C	Ø115 x 3mm	Ø4.5"	Steel	Ø22mm	1	
PTC/115C50	NEW	Ø115 x 3mm	Ø4.5"	Steel	Ø22mm	50
PTC/125C	Ø125 x 3mm	Ø5"	Steel	Ø22mm	1	
PTC/150C	Ø150 x 1.6mm	Ø6"	Steel	Ø22mm	1	
PTC/230C	Ø230 x 3mm	Ø9"	Steel	Ø22mm	1	
PTC/300C	Ø305 x 2.8mm	Ø12"	Steel	Ø25.4mm	1	
PTC/355C	Ø355 x 3mm	Ø14"	Steel	Ø25.4mm	1	
PTC/3CT	Ø75 x 1.2mm	Ø3"	Stainless Steel	Ø10mm	1	
PTC/3CT100	NEW	Ø75 x 1.2mm	Ø3"	Stainless Steel	Ø10mm	100
PTC/100CET	Ø100 x 1.2mm	Ø4"	Stainless Steel	Ø16mm	1	
PTC/100CET5	Ø100 x 1.2mm	Ø4"	Stainless Steel	Ø16mm	5	
PTC/100CET100	NEW	Ø100 x 1.2mm	Ø4"	Stainless Steel	Ø16mm	100
PTC/100CT	Ø100 x 1.6mm	Ø4"	Stainless Steel	Ø16mm	1	
PTC/100CT50	NEW	Ø100 x 1.6mm	Ø4"	Stainless Steel	Ø16mm	50
PTC/115CET	Ø115 x 1.2mm	Ø4.5"	Stainless Steel	Ø22mm	1	
PTC/115CET50	NEW	Ø115 x 1.2mm	Ø4.5"	Stainless Steel	Ø22mm	50
PTC/115CT	Ø115 x 1.6mm	Ø4.5"	Stainless Steel	Ø22mm	1	
PTC/115CT5	Ø115 x 1.6mm	Ø4.5"	Stainless Steel	Ø22mm	5	
PTC/115CET5	Ø115 x 1.2mm	Ø4.5"	Stainless Steel	Ø22mm	5	
PTC/115CET50	NEW	Ø115 x 1.2mm	Ø4.5"	Stainless Steel	Ø22mm	50
PTC/115CET100	NEW	Ø115 x 1.2mm	Ø4.5"	Stainless Steel	Ø22mm	100
PTC/125CET	Ø125 x 1.2mm	Ø5"	Stainless Steel	Ø22mm	1	
PTC/125CT	Ø125 x 1.6mm	Ø5"	Stainless Steel	Ø22mm	1	
PTC/230CT	Ø230 x 2mm	Ø9"	Stainless Steel	Ø22mm	1	
PTC/230CT50	Ø230 x 2mm	Ø9"	Stainless Steel	Ø22mm	50	

B



B



B SEE BELOW

Metal Cutting Discs - Ø22mm Bore

General-purpose flat cutting discs recommended for use with Sealey and other manufacturers of grinding and cutting power tools. Also suitable for cutting stainless steel. Supplied in metal tin.

Model No:	PTC11510CET	PTC11510CETD
Disc Size:	Ø115 x 1.2mm	Ø115 x 1.2mm
Pack Qty:	(x10)	Display Box (10 x 10)



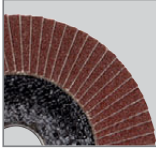

ALUMINIUM OXIDE FLAP DISCS

Aluminium oxide flap discs are ideal for occasional trade use. Available in various grades suitable for rust removal, weld dressing, material removal and surface preparation.



ZIRCONIUM FLAP DISCS

Zirconium are our premium grade flap discs offering strength and durability with fast stock removal. These discs are recommended for frequent professional use.



A SEE BELOW

Aluminium Oxide Flap Discs

Aluminium oxide flap discs for descaling, rust removal, weld preparation, weld cleaning and general surface preparation. Abrasive flaps are attached to a rigid disc with epoxy adhesive, so does not require backing pad. Depressed centre discs suitable for electric and air tools.

Model No:	Grit:	Disc Size Metric:	Disc Size Imperial:	Bore:
FD10040E	40	Ø100mm	Ø4"	Ø16mm
FD10060E	60	Ø100mm	Ø4"	Ø16mm
FD10080E	80	Ø100mm	Ø4"	Ø16mm
FD100120E	120	Ø100mm	Ø4"	Ø16mm
FD11540E	40	Ø115mm	Ø4.5"	Ø22mm
FD11560E	60	Ø115mm	Ø4.5"	Ø22mm
FD11580E	80	Ø115mm	Ø4.5"	Ø22mm
FD115120E	120	Ø115mm	Ø4.5"	Ø22mm
FD12540E	40	Ø125mm	Ø5"	Ø22mm
FD12560E	60	Ø125mm	Ø5"	Ø22mm
FD12580E	80	Ø125mm	Ø5"	Ø22mm
FD125120E	120	Ø125mm	Ø5"	Ø22mm

B SEE BELOW

Zirconium Flap Discs

Zirconium flap discs for descaling, rust removal, weld preparation, weld cleaning and general surface preparation. More durable than normal sanding discs. Abrasive flaps are attached to rigid disc with epoxy adhesive, so does not require backing pad. Depressed centre discs suitable for electric and air tools.

Model No:	Grit:	Disc Size Metric:	Disc Size Imperial:	Bore:
FD10040	40	Ø100mm	Ø4"	Ø16mm
FD10060	60	Ø100mm	Ø4"	Ø16mm
FD10080	80	Ø100mm	Ø4"	Ø16mm
FD100120	120	Ø100mm	Ø4"	Ø16mm
FD11540	40	Ø115mm	Ø4.5"	Ø22mm
FD11560	60	Ø115mm	Ø4.5"	Ø22mm
FD11580	80	Ø115mm	Ø4.5"	Ø22mm
FD115120	120	Ø115mm	Ø4.5"	Ø22mm
FD12540	40	Ø125mm	Ø5"	Ø22mm
FD12560	60	Ø125mm	Ø5"	Ø22mm
FD12580	80	Ø125mm	Ø5"	Ø22mm
FD125120	120	Ø125mm	Ø5"	Ø22mm

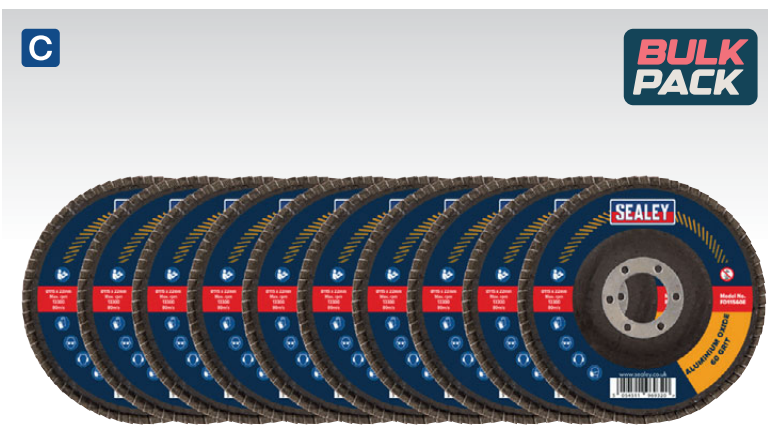

C FD115EMIX

Ø115mm Aluminium Oxide Flap Discs - Assorted Grit - Pack of 10

Aluminium oxide flap discs for descaling, rust removal, weld preparation, weld cleaning and general surface preparation. Pack contains four different levels of abrasion, for assorted applications and finishes. Abrasive flaps are attached to rigid disc with epoxy adhesive, so does not require backing pad. Depressed centre discs suitable for electric and air tools.

Disc Size:	Ø115mm
Bore:	Ø22mm
Grit:	40G (x3), 60G (x4), 80G (x2), 120G (x1)

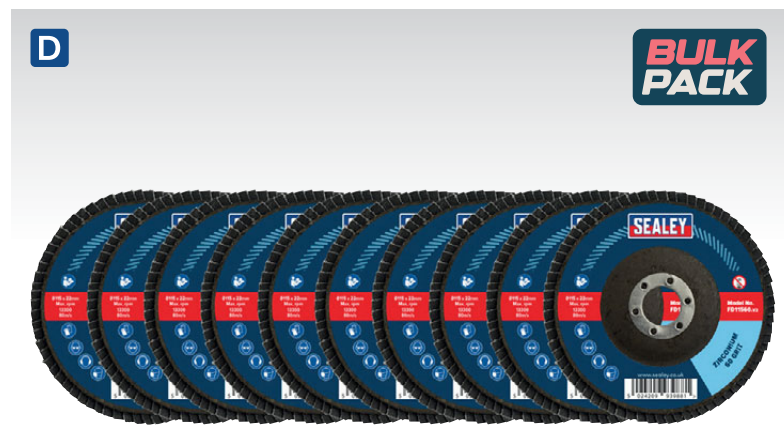

D FD115MIX

Ø115mm Zirconium Flap Discs - Assorted Grit - Pack of 10

Zirconium flap discs for descaling, rust removal, weld preparation, weld cleaning and general surface preparation. More durable than normal sanding discs. Pack contains four different levels of abrasion, for assorted applications and finishes. Abrasive flaps are attached to rigid disc with epoxy adhesive, so does not require backing pad. Depressed centre discs suitable for electric and air tools.

Disc Size:	Ø115mm
Bore:	Ø22mm
Grit:	40G (x3), 60G (x4), 80G (x2), 120G (x1)

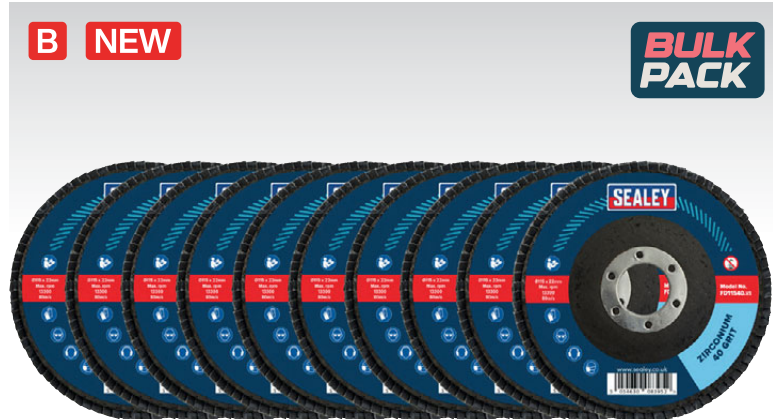
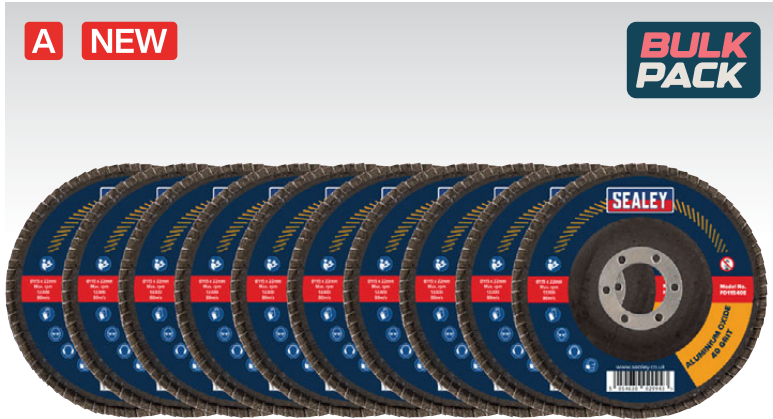

A SEE BELOW

Ø115mm Aluminium Oxide Flap Discs Ø22mm Bore - Packs of 10

Aluminium oxide flap discs for descaling, derusting, weld preparation, weld cleaning and general surface preparation. Pack contains four different levels of abrasion for assorted applications and finishes. Abrasive flaps are attached to rigid disc with epoxy adhesive - does not require backing pad. Depressed centre discs suitable for electric and air tools.

Model No:	Grit:	Disc Size Metric:	Disc Size Imperial:	Bore:
FD11540E10	40	Ø115mm	Ø4.5"	Ø22mm
FD11560E10	60	Ø115mm	Ø4.5"	Ø22mm
FD11580E10	80	Ø115mm	Ø4.5"	Ø22mm
FD115120E10	120	Ø115mm	Ø4.5"	Ø22mm

B SEE BELOW

Ø115mm Zirconium Flap Discs Ø22mm Bore - Packs of 10

Zirconium flap discs for descaling, derusting, weld preparation, weld cleaning and general surface preparation. More durable than normal sanding discs. Abrasive flaps are attached to rigid disc with epoxy adhesive - does not require backing pad. Depressed centre discs suitable for electric and air tools.

Model No:	Grit:	Disc Size Metric:	Disc Size Imperial:	Bore:
FD11540I0	40	Ø115mm	Ø4.5"	Ø22mm
FD11560I0	60	Ø115mm	Ø4.5"	Ø22mm
FD11580I0	80	Ø115mm	Ø4.5"	Ø22mm
FD115120I0	120	Ø115mm	Ø4.5"	Ø22mm



Ø115mm
Premier
SV20 SERIES



C CP20VAGX

20V SV20 Series Ø115mm Brushless Angle Grinder - Body Only

Ergonomic, lightweight and compact design. Brushless motor gives improved performance and requires less maintenance than the brushed equivalent, giving you a more efficient, longer lasting tool. Features spindle lock for quick disc changes and adjustable disc guard. Supplied with side/top handle and soft grip for added comfort and control. Slide on/off lock on switch. Discs not included, see table below. Requires compatible 20V battery and mains charger, sold separately, see page 860. For our full range of SV20 Series power tools, see pages 844 to 872.

Motor Power:	48W
Disc Size:	Ø115mm
No-Load Speed:	10000rpm
Spindle Size:	M14
Noise Power/Pressure:	97/86dB(A)
Vibration/Uncertainty:	5.598/1.5m/s ²
Optional Grinding Disc:	PTC/115G
Optional Cutting Disc:	PTC/115C
Body Weight:	1.6kg



750W
Ø100mm

D SAG101

Ø100mm Angle Grinder 750W

Suitable for a variety of trade applications. Features heavy-duty alloy bevel gear head with spindle lock for fast loading/unloading of discs. Vibration reducing double injection composite body with rubber coating for added comfort. Powerful 750W heavy-duty motor produces 12000rpm (no-load speed). Tool-less wheel guard adjustment. Built-in LED power indicator. Supplied with side handle and spanner. Discs not included, see table below.

Disc Size:	Ø100mm
Spindle Size:	M10 x 1.5mm
Motor Power:	750W
No-Load Speed:	12000rpm
Noise Power/Pressure:	99/88dB(A)
Vibration/Uncertainty:	6.92/1.5m/s ²
Supply:	230V
Plug Type:	3-Pin
Power Supply Cable Length:	2m
Optional Grinding Disc:	PTC/100G
Optional Cutting Disc:	PTC/100C
Weight:	1.8kg



900W
Ø115mm

E SAG115

Ø115mm Angle Grinder 900W

Suitable for a variety of trade applications. Features heavy-duty alloy bevel gear head with spindle lock for fast loading/unloading of discs. Vibration reducing double injection composite body with rubber coating for added comfort. Powerful 900W heavy-duty motor produces 12000rpm (no-load speed). Tool-less wheel guard adjustment. Built-in LED power indicator. Supplied with side handle and spanner. Discs not included, see table below.

Disc Size:	Ø115mm
Spindle Size:	M14
Motor Power:	900W
No-Load Speed:	12000rpm
Noise Power/Pressure:	98/87dB(A)
Vibration/Uncertainty:	6.18/1.5m/s ²
Supply:	230V
Plug Type:	3-Pin
Power Supply Cable Length:	2m
Optional Grinding Disc:	PTC/115G
Optional Cutting Disc:	PTC/115C
Weight:	1.8kg

A TS19024

Ø190 x 30mm Trade Circular Saw Blade - 24tpu

Made from high tensile steel. Tungsten carbide tipped (TCT) saw blades, for super sharp, fast, long-lasting cutting performance. Supplied with two reducing bushes, making the blade suitable for 24mm and 18mm bore machines.

Material:	Diameter:	Bore:	Teeth:
Wood	Ø190mm	Ø30mm	24tpu

B TPS30560

Ø305 x 25.4mm Trade Plus Circular Saw Blade - 60tpu

Tungsten carbide tipped (TCT) saw blade, for super sharp, fast, long-lasting cutting performance. Laser cut slots for better heat dissipation, which increase the life of the blade. Ultra-thin blade allows for a cleaner cut. Stops any breakout, making it ideal for worktops and laminates. Supplied with two reducing bushes, making the blade suitable for 24mm and 18mm bore machines.

Material:	Diameter:	Bore:	Teeth:
Wood/Mild Steel	Ø305mm	Ø25.4mm	60tpu

C SEE BELOW

Mitre/Radial Arm Cross Cutting Blades

Made from high tensile steel, with gravity circle for improved balance. Tungsten carbide tipped (TCT) saw blades, for super sharp, fast, long-lasting cutting performance. Stops any breakout, making it ideal for worktops and laminates.

Model No:	Materials:	Diameter:	Bore:	Teeth:	Finish:
25060	Chipboard/Plywood	Ø250mm	Ø30mm	60tpu	Fine
25080/ALI	Wood/Aluminium/Plastic	Ø250mm	Ø30mm	80tpu	Fine

D TS10P.601

Ø254mm Blade for TS10P 40tpu

Table saw blade for Model No. TS10P.

Blade Size:	Ø254 x 2.8mm
Bore:	Ø30mm
Teeth:	40tpu
Application:	TS10P



E SM85B20

20tpu Circular Saw Blade Ø85 x 15 x 1.3mm

Tungsten carbide tipped (TCT) saw blades with hardened steel teeth. Suitable for circular saws such as Model No. CP108VCSBO. Size/Bore: Ø85 x 1.3mm/Ø15mm.

Blade Size(s):	Size/Bore: Ø85 x 1.3mm/Ø15mm
	Max RPM 17,000rpm, Kerf size 1.3mm
Bore:	15mm
Teeth:	20
Material:	Wood

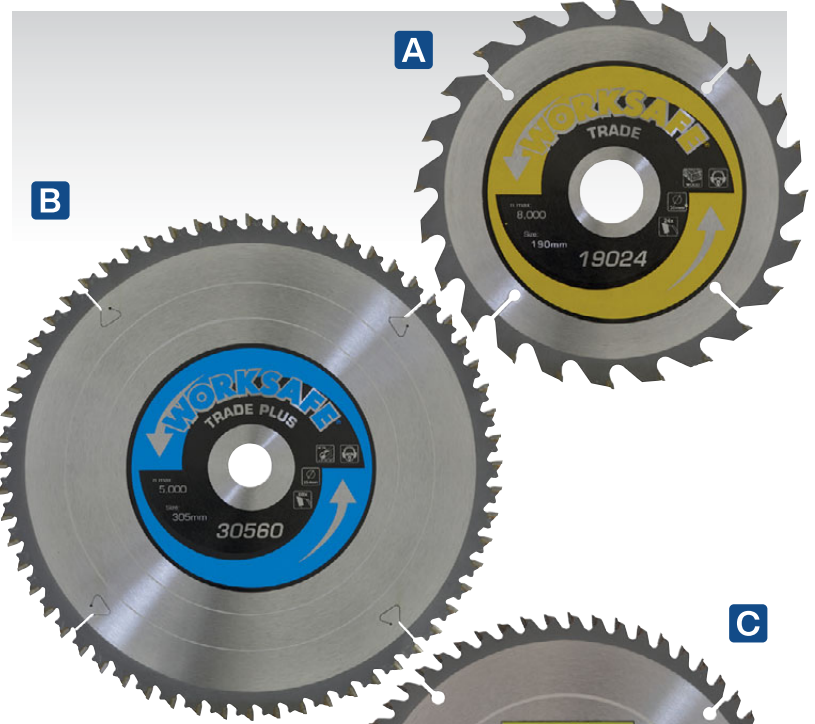

F SEE BELOW

Multipurpose Cut-Off Saw Blades

Multipurpose blades suitable for cutting steel, aluminium, wood and plastic. Cuts nail-embedded wood easily and cuts steel with reduced sparks and heat.

Model No:	SMS216B	SMS255B
Blade Size:	Ø216 x 2.4mm	Ø250 x 2.4mm
Bore:	Ø30mm	Ø30mm
Teeth:	48tpu	60tpu
Application:	SMS216	SMS255



G SEE BELOW

Cut-Off Saw Blades

Tungsten carbide tipped (TCT) saw blade with hardened steel teeth. Suitable for cutting steel, wood, plastics and aluminium alloy.

Model No:	SM180B36	SM355B72
Blade Size:	Ø180 x 1.9mm	Ø355 x 2.4mm
Bore:	Ø20mm	Ø25.4mm
Application:	SM180B	SM355B



A BWBS40DB
Wire Brushes Assorted Sizes - Display Box of 40

Suitable for use with power tools up to the maximum rated rpm. Crimped brassed steel filaments add extra rigidity and cleaning power. Eight of each size/type supplied in countertop display box.

Contents:	Brushes; Wire Cup; 50, 75mm, Flat Wire; 50, 75mm, 25mm Decarbonising/Cleaning Wire (8 of each)
Shaft:	Ø6mm
Maximum Speed:	4500rpm



B SEE BELOW
Wire Cup Brushes

Suitable for use with power drills. Crimped brassed steel filaments add extra rigidity and cleaning power.

Model No:	Shaft:	Diameter:	Max. Speed:
SCB50	Ø6mm	Ø50mm	4500rpm
SCB75	Ø6mm	Ø75mm	4500rpm



D SEE BELOW
Flat Top Decarbonising Brushes

Flat trimmed brushes with brassed and crimped filaments for extra rigidity.

Model No:	Shaft:	Trim Length:	Trim Diameter:
VS1802	Ø6mm	20mm	Ø13mm
VS1803	Ø6mm	28mm	Ø25mm



C VS1801
2pc Decarbonising Brush Set

Brassed and crimped steel brushes with flat and pointed fill. Suitable for decarbonising cylinder head ports and components.

Trim Diameter:	Flat; Ø15mm, Pointed; Ø12mm
Trim Length:	Flat; 25mm, Pointed; 25mm



E TKFS75
Ø75mm Twist Knot Flat Wire Wheel
Ø6mm Shaft

Diameter:	Ø75mm
Shaft Diameter:	Ø6mm
Maximum Speed:	12000rpm



F SEE BELOW
Flat Wire Brushes

Suitable for use with power drills. Crimped brassed steel filaments add extra rigidity and cleaning power.

Model No:	Shaft:	Diameter:	Max. Speed:
SFB50	Ø6mm	Ø50mm	4500rpm
SFB75	Ø6mm	Ø75mm	4500rpm
SFB100	Ø6mm	Ø100mm	4500rpm



G SEE BELOW
Flat Wire Brushes

Flat wire brushes with crimped stainless steel filaments.

Model No:	Shaft:	Diameter:	Max. Speed:
SFBS50	Ø6mm	Ø50mm	4500rpm
SFBS75	Ø6mm	Ø75mm	4500rpm
SFBS100	Ø6mm	Ø100mm	4500rpm



H BWBS03
3pc Wire Brush Set

Contents:	Brushes; Ø50mm Wire Cup, Ø50mm Flat Wire, Ø25mm Decarbonising/Cleaning Wire
Shaft:	Ø6mm
Maximum Speed:	4500rpm



I BWBS05
5pc Wire Brush Set

Contents:	Brushes; Wire Cup; Ø50mm, 75mm, Flat Wire; Ø50mm, 75mm, Ø25mm Decarbonising/Cleaning Wire
Shaft:	Ø6mm
Maximum Speed:	4500rpm



J BWBS08
8pc Wire Brush Set

Contents:	Brushes; Flat Wire; Ø25, 40, 50, 65, 75mm, Removable Shafts (x3)
Shaft:	Ø6mm
Maximum Speed:	4500rpm

A



B



C



Electric Angle Grinders

For our full range of Electric Angle Grinders, see pages 878 to 879.

A SEE BELOW

Twist Knot Wire Cup Brushes

Suitable for use with power tools up to the maximum rated rpm. Twisted steel filaments give more aggressive cleaning action - ideal for heavy rust removal.

Model No:	Thread:	Diameter:	Max. Speed:
TKCB652	M10 x 1.25mm	Ø65mm	12500rpm
TKCB65	M10 x 1.5mm	Ø65mm	12500rpm
TKCB651	M14 x 2mm	Ø65mm	12500rpm
TKCB100	M14 x 2mm	Ø100mm	8500rpm

B SEE BELOW

Conical Wire Brushes

Suitable for use with power tools up to the maximum rated rpm. Twisted steel filaments give more aggressive cleaning action - ideal for heavy rust removal.

Model No:	Thread:	Diameter:	Max. Speed:
CWB100	M10 x 1.5mm	Ø100mm	12500rpm
CWB101	M14 x 2mm	Ø100mm	12500rpm
CWB115	M14 x 2mm	Ø115mm	12500rpm

C SEE BELOW

Brassed Steel Cup Brushes

Suitable for use with power tools. Crimped brass steel filaments add extra rigidity and cleaning power.

Model No:	Thread:	Diameter:	Max. Speed:
CBC75	M10 x 1.5mm	Ø75mm	12500rpm
CBC752	M14 x 2mm	Ø75mm	12500rpm
CBC100	M14 x 2mm	Ø100mm	8500rpm
CBC125	M14 x 2mm	Ø125mm	6500rpm

D



D HRK01

Headlight Restoration Kit

3-Stage headlight restoration kit designed to eliminate the worst cases of headlight degradation, yellowing, oxidation and scratches. Includes everything needed to restore the cloudiest lenses. Get great results on most plastic lenses, such as tail lights, trailers, boat windows, helmet visors, motorcycle windscreens, snowmobiles and more. Improves visibility and safety. One kit is intended to restore two headlight lenses.

Contents: Sanding Discs; P800 (x2), P1200 (x2), P2000 (x2), M10 Male to Female Adaptor, 40g Polishing Paste (x2), 3ml Protection Liquid (x2), 3m x 20mm Masking Tape, Backing Pad M10 Female Thread, Orange Sponge Disc, Cleaning Cloth

E



E SEE BELOW

Flap Wheels - Ø6mm Shaft

Aluminium oxide flap wheels ideal for finishing curved and intricate metal surfaces.

Model No:	Shaft:	Wheel Size:	Wheel Thickness:	Grit:
FW251060	Ø6mm	Ø25mm	10mm	60
FW251080	Ø6mm	Ø25mm	10mm	80
FW252060	Ø6mm	Ø25mm	20mm	60
FW252080	Ø6mm	Ø25mm	20mm	80
FW402040	Ø6mm	Ø40mm	20mm	40
FW402060	Ø6mm	Ø40mm	20mm	60
FW402080	Ø6mm	Ø40mm	20mm	80
FW403040	Ø6mm	Ø40mm	30mm	40
FW403060	Ø6mm	Ø40mm	30mm	60
FW403080	Ø6mm	Ø40mm	30mm	80
FW502540	Ø6mm	Ø50mm	25mm	40
FW502560	Ø6mm	Ø50mm	25mm	60
FW502580	Ø6mm	Ø50mm	25mm	80
FW603040	Ø6mm	Ø60mm	30mm	40
FW603060	Ø6mm	Ø60mm	30mm	60
FW603080	Ø6mm	Ø60mm	30mm	80
FW805040	Ø6mm	Ø80mm	50mm	40
FW805060	Ø6mm	Ø80mm	50mm	60
FW805080	Ø6mm	Ø80mm	50mm	80

F



F SSK20

20pc Spiral Band Sanding Kit

Suitable for sanding and surface preparation for curves, bends and confined areas. Easy-to-fit rubber drums.



Safety Goggles

For our full range of Safety Goggles, see pages 1277 to 1279.

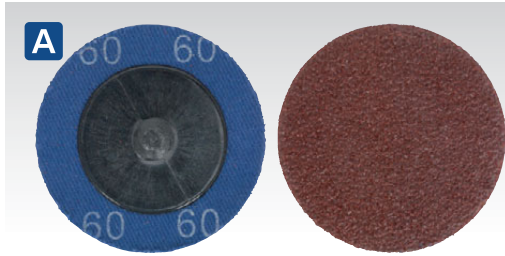
**A SEE BELOW****Quick Change Sanding Discs - Packs of 10**

Sanding discs suitable for use with mini air sanders.

Model No:	Disc Size:	Grit:	Pack Qty:
PTCQC5060	Ø50mm	60	10
PTCQC5080	Ø50mm	80	10
PTCQC50120	Ø50mm	120	10
PTCQC7560	Ø75mm	60	10
PTCQC7580	Ø75mm	80	10
PTCQC75120	Ø75mm	120	10

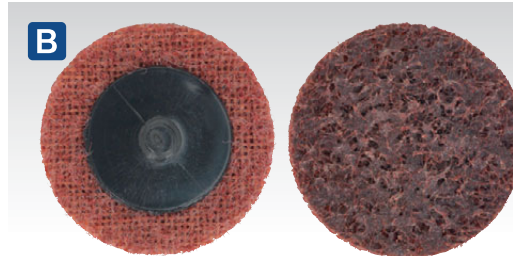
**B SEE BELOW****Quick Change Preparation Pads - Packs of 10**

Preparation pads for use with mini air sanders.

Model No:	Pad Size:	Grade:	Pack Qty:
PTCQC50F	Ø50mm	Fine	10
PTCQC50M	Ø50mm	Medium	10
PTCQC50C	Ø50mm	Coarse	10
PTCQC75F	Ø75mm	Fine	10
PTCQC75M	Ø75mm	Medium	10
PTCQC75C	Ø75mm	Coarse	10

**C SEE BELOW****Quick Change Backing Pads 1/4"UNC**

Backing pads for use with quick change sanding discs and preparation pads. Suitable for use with mini air sanders.

Model No:	Pad Size:	Thread Size:
PTCQCBP50	Ø50mm	1/4"UNC
PTCQCBP75	Ø75mm	1/4"UNC

**D E540****40pc Multipurpose Rotary Tool & Engraver Kit**

Multipurpose high-speed power tool with on/off and electronic variable speed controls. Stepless control between 10,000 and 32,000rpm. Spindle lock for fast tool changes. Supplied with a full range of tips, wheels, sanding discs/bands, dressing stone, chuck spanner and flexible rotary shaft. Suitable for carving, shaping, deburring, drilling, engraving, cutting and tool sharpening. Supplied in storage case.

Power - Supply:	135W - 230V
Speed Range:	10000-32000rpm
Collets:	2.3, 3mm
Twist Drills:	2.3, 3mm
Mounted Points:	10
Diamond Tipped Engraving Heads:	2
Sanding Cylinder:	12.7 x 15mm
Accessories:	Sanding Bands (x4), Sanding Discs (x3), Cutting Discs (x8), Polishing Wheels (x4), Dressing Stone, Spanner, Flexible Rotary Shaft

**E SEE BELOW****Ø50mm Sanding Discs - Packs of 10**

Hook-and-loop sanding discs for use with Sealey and other makes of mini air sanders.

Model No:	Disc Size:	Grit:	Pack Qty:
SA701D60G	Ø50mm	60	10
SA701D80G	Ø50mm	80	10
SA701D120G	Ø50mm	120	10

**F SEE BELOW****Ø75mm Sanding Discs - Packs of 10**

Hook-and-loop sanding discs for use with Sealey and other makes of mini air sanders.

Model No:	Disc Size:	Grit:	Pack Qty:
SA722D60G	Ø75mm	60	10
SA722D80G	Ø75mm	80	10
SA722D120G	Ø75mm	120	10

**G GSA70****Ø50mm Disc Air Orbital Sander**

Composite cover moulded around lightweight aluminium alloy housing reduces effects of chill on operator's hands and provides added control. Air motor with quality bearings for smooth and powerful operation. Fitted with safety release trigger control to prevent accidental operation. Exhaust outlet adjusts 360° keeping airflow away from operator. Supplied with Ø50mm pad and spanner.

Pad Size:	Ø50mm
Thread Size:	M6 x 1mm
No-Load Speed:	15000rpm
Orbit Size:	Ø3mm
Air Consumption:	4cfm
Operating Pressure:	90psi
Inlet Size:	1/4" BSP
Noise Power/Pressure:	101/90dB(A)
Vibration/Uncertainty:	4.5/2.25m/s ²
Weight:	0.7kg

**H SA721****Ø75mm Air Polisher**

Composite lightweight housing reduces effects of chill on operator's hands. Adjustable speed control on side of motor housing. Air motor with quality bearings for smooth and powerful operation. Ideal for sanding down smaller areas prior to smart repairs or spot refinishing. Supplied with Ø75mm hook-and-loop pad. Suitable for the professional workshop.

Pad Size:	Ø75mm
Thread Size:	5/16" UNF
Free Speed:	15000rpm
Air Consumption:	3cfm
Operating Pressure:	90psi
Inlet Size:	1/4" BSP
Noise Power/Pressure:	88.3/77.2dB(A)
Vibration/Uncertainty:	4.25/0.85m/s ²
Weight:	0.5kg



A RTA138CGD
138pc Rotary Tool Cutting Disc Set

For cutting, trimming and deburring in small confined areas. Compatible with Sealey and other popular branded rotary tools.



B RTA7FW
7pc Ø30mm Rotary Tool Flap Wheel Set

Ideal for surface treatment, smoothing corners and deburring in small, confined areas. Set includes 60Grit (x4) and 80Grit (x3) flap wheels. Compatible for use with Sealey and other popular brands of drills and die grinders.



C RTA18WB
18pc Rotary Tool Brush Set

Set includes soft brass, steel wire brushes and nylon brushes. Crimped brushes with flat and pointed fill. For cleaning, dusting, polishing and surface preparation in small confined areas. Compatible with Sealey and other popular branded rotary tools.



D RTA63SB
63pc Rotary Tool Sanding Bands Set

For sanding, shaping and surface preparation in small confined areas. Compatible with Sealey and other popular branded rotary tools.



E SEE BELOW
Flap Wheels Ø6mm Shaft - Packs of 5

Aluminium oxide flap wheels ideal for finishing curved and intricate metal surfaces. Supplied in packs of 5.

Model No:	Wheel Size:	Wheel Width:	Shaft Diameter:	Grit:
FW2510405	Ø25mm	10mm	Ø6mm	40
FW2510605	Ø25mm	10mm	Ø6mm	60
FW2510805	Ø25mm	10mm	Ø6mm	80
FW2520405	Ø25mm	20mm	Ø6mm	40
FW2520605	Ø25mm	20mm	Ø6mm	60
FW2520805	Ø25mm	20mm	Ø6mm	80
FW4020405	Ø40mm	20mm	Ø6mm	40
FW4020605	Ø40mm	20mm	Ø6mm	60
FW4020805	Ø40mm	20mm	Ø6mm	80
FW4030405	Ø40mm	30mm	Ø6mm	40
FW4030605	Ø40mm	30mm	Ø6mm	60
FW4030805	Ø40mm	30mm	Ø6mm	80
FW5025405	Ø50mm	25mm	Ø6mm	40
FW5025605	Ø50mm	25mm	Ø6mm	60
FW5025805	Ø50mm	25mm	Ø6mm	80
FW6030405	Ø60mm	30mm	Ø6mm	40
FW6030605	Ø60mm	30mm	Ø6mm	60
FW6030805	Ø60mm	30mm	Ø6mm	80
FW8050405	Ø80mm	50mm	Ø6mm	40
FW8050605	Ø80mm	50mm	Ø6mm	60
FW8050805	Ø80mm	50mm	Ø6mm	80



F SEE BELOW
Flap Wheels Assortment Ø6mm Shaft Packs of 5

Aluminium oxide flap wheels on Ø6mm shaft. Suitable for use with power drills. Supplied in packs of 5. Pack includes 40Grit (x1), 60Grit (x2) and 80Grit (x2).

Model No:	Wheel Size:	Wheel Width:	Shaft Diameter:	Grit:
FW2510ASS	Ø25mm	10mm	Ø6mm	40 (x1) 60 (x2) 80 (x2)
FW2520ASS	Ø25mm	20mm	Ø6mm	40 (x1) 60 (x2) 80 (x2)
FW4020ASS	Ø40mm	20mm	Ø6mm	40 (x1) 60 (x2) 80 (x2)
FW4030ASS	Ø40mm	30mm	Ø6mm	40 (x1) 60 (x2) 80 (x2)
FW5025ASS	Ø50mm	25mm	Ø6mm	40 (x1) 60 (x2) 80 (x2)
FW6030ASS	Ø60mm	30mm	Ø6mm	40 (x1) 60 (x2) 80 (x2)
FW8050ASS	Ø80mm	50mm	Ø6mm	40 (x1) 60 (x2) 80 (x2)



G-P SEE BELOW
Mounted Wheels

Abrasive heads. Suitable for use with die grinders and drills. Supplied individually.

Model No:	Head Diameter:	Shaft Diameter:	Shaft Length:	Overall Length:
G MW01	Ø25mm	Ø6mm	25mm	52mm
H MW02	Ø13mm	Ø6mm	25mm	53mm
I MW03	Ø25mm	Ø6mm	12mm	44mm
J MW04	Ø19mm	Ø6mm	26mm	53mm
K MW05	Ø25mm	Ø6mm	38mm	65mm
L MW06	Ø13mm	Ø3mm	18mm	48mm
M MW07	Ø10mm	Ø3mm	15mm	44mm
N MW08	Ø15mm	Ø3mm	19mm	48mm
O MW09	Ø12mm	Ø3mm	10mm	42mm
P MW10	Ø13mm	Ø3mm	16mm	45mm

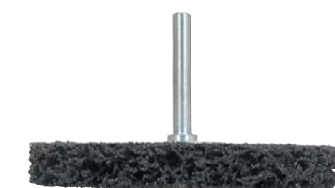

A-B SEE BELOW

Polycarbide Wheels

Versatile abrasive wheels for use with Sealey and other leading makes of grinding and cutting power tools. Suitable for removal of paint/rust and other flaking materials when a less harsh abrasive is needed.

A Model No:	PTC/SW100
Size:	Ø100 x 13mm
Spindle Size:	Ø6mm
B Model No:	PTC/CW115
Size:	Ø115 x 13mm
Bore:	Ø22mm



C-H SEE BELOW

Backing Pads & Nuts

Backing pads for grinders and sanders.

Model No:	Pad Size:	Suitability:	Thread Size:
C PTC/BP3	Ø90mm	Ø100mm	n/a
D PTC/BP4	Ø104mm	Ø115mm	n/a
E PTC/BP7/5/8	Ø171mm	Ø180mm	5-8"UNC

Lock nuts for backing pads.

Model No:	Thread Size:
F PTC/BP3/NUT	M10 x 1.25mm
G PTC/BP3/NUT15	M10 x 1.5mm
H PTC/BP4/NUT	M14 x 2mm



I SAG115

Ø115mm Angle Grinder 900W

For full details, see page 878.



J PTC/QCNM14

M14 Quick Change Angle Grinder Locking Nut

Quick change locking nut for angle grinders. Easy-to-use, can tighten and release discs by hand. Suitable for Sealey and most popular branded angle grinders.

Thread Size:	M14 x 2mm
--------------	-----------



L SEE BELOW

Rubber Backing Pads with Locking Nut

For use with fibre backed sanding discs.

Model No:	Diameter:	Thread Size:
RBP116	Ø116mm	M14
RBP125	Ø125mm	M14
RBP180	Ø180mm	M14



K SEE BELOW

Grinding Stones

Aluminium oxide stones. Supplied with reduction bushes where indicated.

Model No:	Size/Bore (Reducer):	Grade:
NBG150/GWC	Ø150mm x 16mm/Ø32(Ø13)mm	A36Q Coarse
NBG150/GWF	Ø150mm x 16mm/Ø32(Ø13)mm	A60P Fine
BG150/15	Ø150mm x 20mm/Ø32(Ø13)mm	A60P Fine
BG150/16	Ø150mm x 20mm/Ø32(Ø13)mm	A36Q Coarse
BG200/15	Ø200mm x 25mm/Ø16mm	A60P Fine
BG200/16	Ø200mm x 25mm/Ø16mm	A36Q Coarse



M PTC/UPW

Universal Pin Spanner

Adjustable from 10-30mm to suit most pin discs found on air and electric grinders and sanders. Comfort profiled and dipped handle.

Size/Type:	10-30mm/4mm Pins
------------	------------------



A SMS2101.SW
Ø200mm Sharpening Stone for SMS2101
 Aluminium oxide sharpening stone for use with Model No. SMS2101, see page 1203.

Bore: Ø12mm



D SMS2101.HW
Ø200mm Honing Wheel for SMS2101
 Leather covered honing wheel for use with Model No. SMS2101.

Bore: Ø12mm



E-G SEE BELOW
Wet & Dry Stone Wheels

E Model No:	SM521GW200W
Size:	Ø200 x 40mm
Bore:	Ø20mm
Grinding Speed:	130rpm
F Model No:	SMS2107GW200W
Size:	Ø200 x 20mm
Bore:	Ø20mm
Grinding Speed:	320rpm
G Model No:	SMS2107GW125D
Size:	Ø125 x 50mm
Bore:	Ø12.7mm
Grinding Speed:	2850rpm

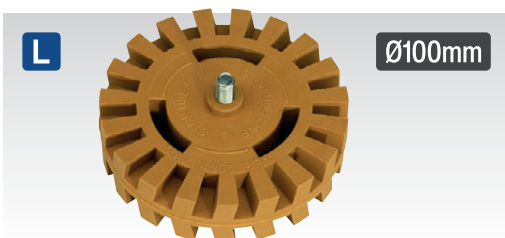

L SA95PXPLUS
Deluxe Stripe Removing Pad
 'Toothed' cutting edges rapidly remove pinstripes or double-sided tape prior to refinishing.

Pad Size:	Ø100 x 27mm
Thread Size:	5/16"UNF
Minimum Diameter:	Ø50mm
Maximum Speed:	4000rpm



B SEE BELOW
Wire Wheels

Brass coated steel wire wheel. Supplied with reduction bushes.

Model No:	Size/Bore (Reducer):
BG150/WW1	Ø150mm x 13mm/Ø32(Ø13mm)
BG150/WW2	Ø150mm x 20mm/Ø32(Ø13mm)
BG200/WW1	Ø200mm x 13mm/Ø32(Ø13mm)



H SA695WA
Angled Wire Wheel for SA695

Size: Ø100 x 25mm



J SA695A
Polycarbide Wheel for SA695

Size: Ø100 x 28mm
Thread: 5/16"UNF



M SA95/PXM
Stripe Removing Pad

Suitable for use in a drill chuck, for removing pinstripes or double-sided tape from panel work prior to refinishing.

Pad Size:	Ø88 x 15mm
Thread Size:	6mm Mandrel
Minimum Diameter:	Ø38mm
Maximum Speed:	4000rpm



C SEE BELOW
Buffing Wheels

Manufactured entirely from cotton. Soft density. Provides high quality finish.

Model No:	Size/Bore:	Type:	Ply:
BG150BW	Ø150mm x 13mm/Ø16mm	Fine	32
BG200BW	Ø200mm x 16mm/Ø16mm	Fine	40
BG150BWC	Ø150mm x 13mm/Ø13mm	Coarse	40
BG200BWC	Ø200mm x 16mm/Ø16mm	Coarse	40

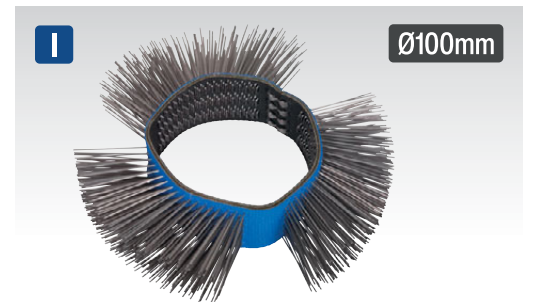

I SA695WS
Straight Wire Wheel for SA695

Size: Ø100 x 25mm



K SA95UNI
Universal Stripe Removing Pad

Suitable for removing pinstripes or double sided tape from panel work prior to refinishing. Waved design to increase airflow and thus prolonging life. 5/16" UNF Fitting with 6mm mandrel adaptor to also allow use with a standard drill.

Pad Size:	Ø88 x 20mm
Thread Size:	5/16"UNF, 6mm Mandrel
Minimum Diameter:	Ø40mm
Maximum Speed:	4000rpm



N SA95/PX
Stripe Removing Pad

Suitable for use with Model No. SA95, for removing pinstripes or double-sided tape from panel work prior to refinishing.

Pad Size:	Ø88 x 16mm
Thread Size:	1/4"UNC
Minimum Diameter:	Ø38mm
Maximum Speed:	4000rpm

A



A WJTASS

Jigsaw Blades Assorted - Pack of 5

Combination of Chrome Vanadium and HSS blades suitable for cutting a variety of materials. Compatible with Sealey and most other popular brands of jigsaw.

Contents: WJT101B - 75mm Wood & Plastics, WJT111C - 75mm Wood & Plastics, WJT144D - 75mm Wood, WJT118A - 55mm Steel & Sheet Metals, WJT118B - 55mm Non-Ferrous Metals and Aluminium

B

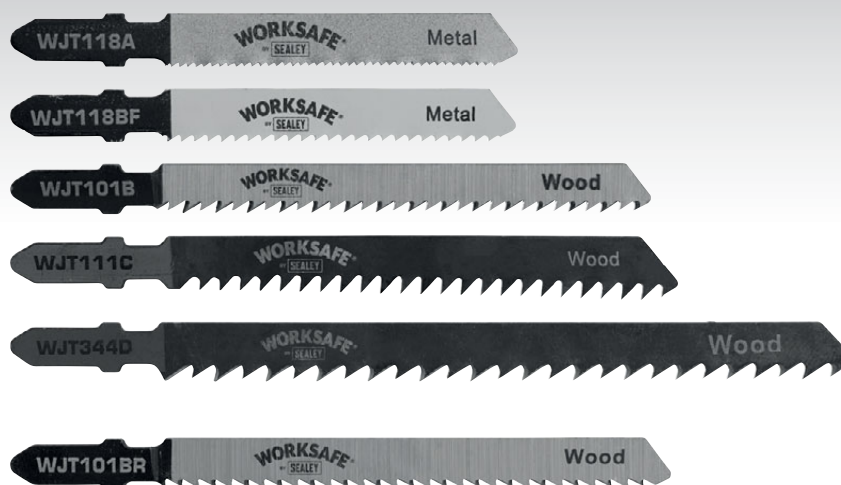

Model No WJT101BR features reversed teeth for cutting on downward stroke.

B SEE BELOW

Jigsaw Blades - Pack of 5

Jigsaw blades compatible with most popular brands of jigsaws.

Model No:	Applications:	Material:	TPI:	Toothed Length:	Pack Qty:
WJT101B	Wood & Plastics	CV-Steel	10	75mm	5
WJT101BR	Wood & Plastics	CV-Steel	10	75mm	5
WJT301CD	Wood & Plastics	CV-Steel	8	90mm	5
WJT111C	Soft Wood & Plastics	CV-Steel	9	75mm	5
WJT144D	Quick Cut for Wood	CV-Steel	6	75mm	5
WJT344D	Quick Cut for Wood	CV-Steel	6	105mm	5
WJT101A	Non-ferrous Metals & Aluminium	Bi-Metal	12	75mm	5
WJT118A	Steel & Sheet Metals up to 2mm	HSS	21	55mm	5
WJT318A	Steel & Sheet Metals up to 2mm	Bi-Metal	21	105mm	5
WJT118B	Non-ferrous Metals & Aluminium	HSS	12	55mm	5
WJT118BF	Non-ferrous Metals & Aluminium & Stainless Steel up to 3mm	Bi-Metal	12	55mm	5
WJTASS	See A for assortment contents				

C

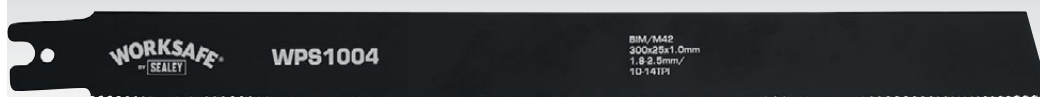

D



D SEE BELOW

Reciprocating Saw Blades - Pack of 5

Reciprocating saw blades compatible with Sealey and most other popular brands of reciprocating saw.

Model No:	Applications:	TPI:	Toothed Length:	Pack Qty:
WRS3021/150	Medium cut for wood, gypsum boards and gas formed concrete	6	130mm	5
WRS3021/300	Medium cut for wood, gypsum boards and gas formed concrete	6	280mm	5
WRS3029/240	Ideal for cutting through green wood	5	220mm	5
WRS3019/225	Suitable for cutting through all types of wood	3	205mm	5
WRS3014/150	Very fine cuts for sheet metals and pipes thicker than 1.2mm	18	130mm	5
WRS3014/200	Universal saw blade for iron, steel and pipes thicker than 1.2mm	18	205mm	5
WRS3014/250	Universal saw blade for iron, steel and pipes thicker than 1.2mm	18	230mm	5
WRS3013/150	Medium cut for iron, steel pipes, non ferrous metals and pallets	14	130mm	5
WRS3013/200	Medium cut for iron, steel pipes, non ferrous metals and pallets	14	205mm	5
WRS3013/250	Medium cut for iron, steel pipes, non ferrous metals and pallets	14	230mm	5
WRS3018/150	Coarse cut for cast iron and steel pipes, on-ferrous metals and pallets	10	130mm	5
WRS3018/280	Coarse cut for cast iron and steel pipes, on-ferrous metals and pallets	10	260mm	5

C SEE BELOW

Pipe Saw Blades - Pack of 5

Rigid/rem/flex pipe saw blades, compatible with Sealey and most other popular brands of reciprocating saw.

Model No:	Material:	TPI:	Toothed Length:	Pack Qty:
WPS1002	Bi-Metal	8	200mm	5
WPS1004	Bi-Metal	10-14	300mm	5

E



E SRS850

850W Reciprocating Saw

For full details, see page 886.

Motor Power:	850W
Supply:	230V
No-Load Speed:	0-2800spm
Vibration/Uncertainty:	22.168/1.5m/s ²
Replacement Blade Set:	SBS3150
Weight:	2.55kg

A

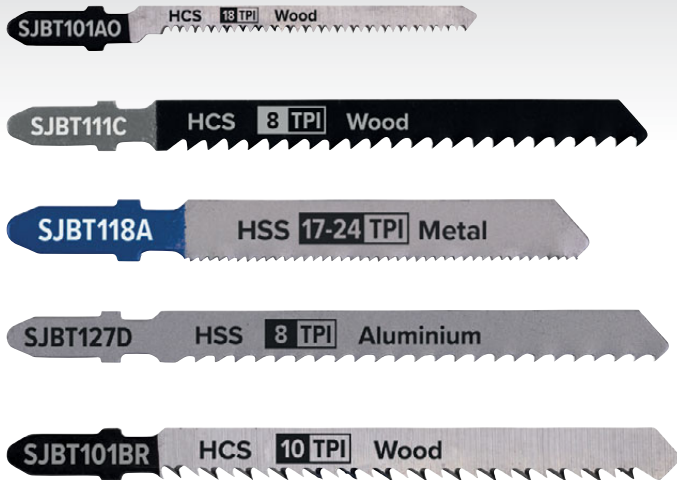

Model No SJBT101BR features reversed teeth for cutting on downward stroke.



A SEE BELOW

Jigsaw Blades - Packs of 5

Suitable for Sealey and most other popular brands of jigsaw.

Model No:	Applications:	TPI:	Toothed Length:	Pack Qty:
SJBT101AO	Wood - Hard	18	83mm	5
SJBT101B	Wood - Hard	10	100mm	5
SJBT101BR	Wood - Hard	10	100mm	5
SJBT101D	Wood - Hard	6	100mm	5
SJBT111C	General - Wood	8	100mm	5
SJBT118A	Metal	17-24	92mm	5
SJBT118AF	Metal	21	75mm	5
SJBT118B	Metal	11-14	92mm	5
SJBT118BF	Metal	12	75mm	5
SJBT118G	Metal	32	75mm	5
SJBT119BO	General - Wood	12	75mm	5
SJBT127D	Aluminium	8	100mm	5
SJBT144D	General - Wood	6	100mm	5

B

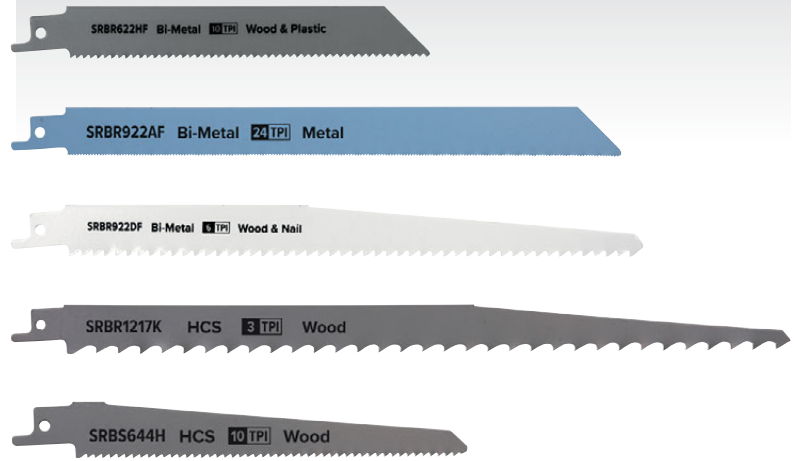

B SEE BELOW

Jigsaw Blades - Packs of 5

Suitable for Sealey and most other popular brands of jigsaw.

Model No:	Applications:	TPI:	Toothed Length:	Pack Qty:
SRBR617K	Pruning & Coarse Wood	3	150mm	5
SRBR1217K	Pruning & Coarse Wood	3	300mm	5
SRBS644D	Clean Wood	6	150mm	5
SRBS644H	Clean Wood	10	150mm	5
SRBS811D	Clean Wood	6	200mm	5
SRBS911D	Clean Wood	6	230mm	5
SRBS1211D	Clean Wood	6	250mm	5
SRBR622HF	Wood & Plastics	10	150mm	5
SRBR922HF	Wood & Plastics	10	230mm	5
SRBR611DF	Wood & Nail	6	150mm	5
SRBR922DF	Wood & Nail	6	230mm	5
SRBR1211DF	Wood & Nail	6	300mm	5
SRBR622EF	Metal	18	150mm	5
SRBR622AF	Metal	24	150mm	5
SRBR922EF	Metal	18	230mm	5
SRBR922AF	Metal	24	230mm	5
SRBRB611F	Multipurpose	5-8	150mm	5
SRBRB922F	Multipurpose	5-8	230mm	5
SRBRB1222F	Multipurpose	5-8	300mm	5

C



C CP20VJSKIT1

20V 2Ah SV20 Series Cordless Jigsaw Kit

For full details, see page 853.

No-Load Speed:	0-2400spm
Cutting Specifications:	
Wood:	80mm
Plastic:	12mm
Steel:	10mm
Metal Pipe:	Ø5-25mm
Noise Power/Pressure:	90/79db(A)
Stroke Length:	25mm
Vibration/Uncertainty:	11.18/1.5m/s ²
Body Only Weight:	2kg

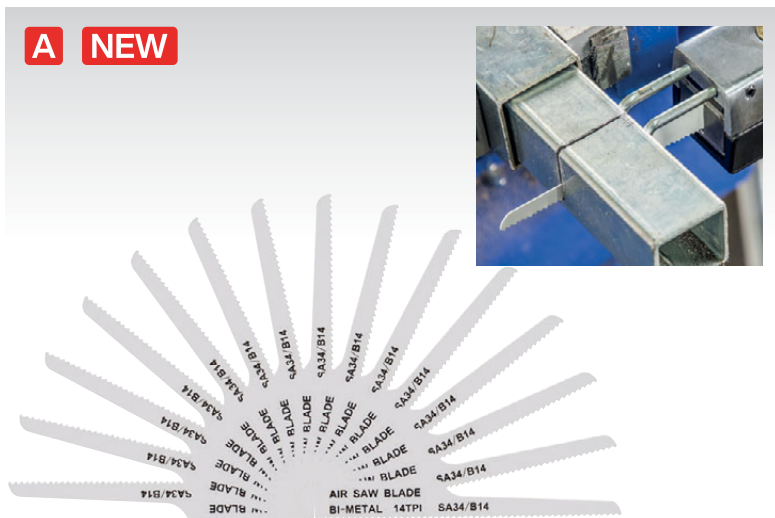

A SEE BELOW

Air Saw Blades - Pack of 15

HSS Air saw blades suitable for Sealey and other leading makes of air saw.

Model No:	Blade Pitch:	Pack Qty:
SA34/B1415	14tpi	15
SA34/B2415	24tpi	15
SA34/B3215	32tpi	15

B SA34MIX

Mixed Air Saw Blades - Pack of 15

HSS Air saw blades suitable for Sealey and other leading makes of air saw. Contents: 14tpi Saw Blades (x3), 24tpi Saw Blades (x9), 32tpi Saw Blades (x3).

Blade Pitch:	Pack Qty:
14tpi (x3), 24tpi (x9), 32tpi (x3)	15



C SEE BELOW

Air Saw Blades - Pack of 15

HSS Air saw blades suitable for Sealey and other leading makes of air saw.

Model No:	Blade Pitch:	Pack Qty:
SA345/B1815	18tpi	15
SA345/B2415	24tpi	15
SA345/B3215	32tpi	15



D SEE BELOW

Air Saw Blades

HSS Air saw blades suitable for Sealey and other leading makes of air saw.

Model No:	Blade Pitch:	Pack Qty:
SA346/B1815	18tpi	15
SA346/B2415	24tpi	15
SA346/B32	32tpi	5
SA346/B3215	32tpi	15

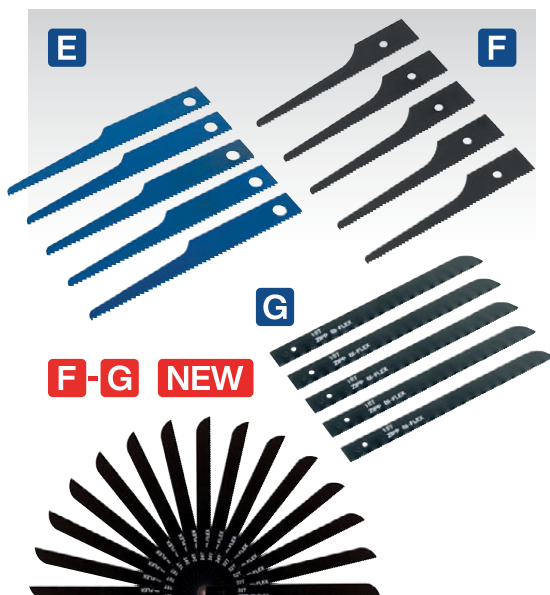

E-G SEE BELOW

HSS Air Saw Blades

HSS Air saw blades, supplied in packs of 5 or 15. Capable of cutting most ferrous metals and plastics. Suitable for use with Sealey Model No's S01045, SA34, SA342, SA347, SA348, SA1006 and other brands of air saw.

Model No:	Pack Qty:	Blade Pitch:
E SA34/B14	5	14tpi
E SA34/B24	5	24tpi
E SA34/B32	5	32tpi
F SA345/B18	5	18tpi
F SA345/B24	5	24tpi
F SA345/B32	5	32tpi
F SA345MIX NEW	15	18tpi (x5), 24tpi (x5), 32tpi (x5)
G SA346/B18	5	18tpi
G SA346/B24	5	24tpi
G SA346MIX NEW	15	18tpi (x5), 24tpi (x5), 32tpi (x5)



H SA34

Reciprocating Air Saw

Suitable for a variety of bodyshop applications such as cutting panels, exhaust work, sills and chassis members. Excellent for initial crash repair preparation when quick removal of damaged panels is required. Fitted with safety trigger device to prevent accidental operation. Supplied with a starter pack of blades. For full specification see page 820.



A SMTA1
3pc Multi-Tool Blade Set

Includes offset cutting blade, offset scraper and a straight scraper. Universal fitting for use with Sealey and other brands of multi-tool (excluding Model No. SMT300Q).

Contents: Offset Cutting Blade, Offset Scraper, Straight Scraper



B SMTC3
3pc Quick Change Multi-Tool Cutting Blade Set

Set of three universal quick change multi-tool attachments finished with blue blades. Cutting blades suitable for wood and metal. Universal fitting for use with Sealey and other brands of multi-tool.

Contents: 10mm Bi-Metal Cutting Blade, 32mm Offset Bi-Metal Cutting Blade, 65mm Offset Bi-Metal Cutting Blade



C SMTB3
3pc Quick Change Multi-Tool Scraper Blade Set

Set of three universal quick change multi-tool attachments finished with SK7 steel blue blades. Ideal for cutting and scraping various materials. Universal fitting for use with Sealey and other brands of multi-tool.

Contents: 28 x 50mm Sharp Scraper, 52 x 45mm Flexible Scraper, 52 x 26mm Rigid Scraper



D SMTS7
7pc All-Purpose Multi-Tool Blade Set

Set of seven universal quick change multi-tool attachments designed to perform a range of tasks. Universal fitting for use with Sealey and other brands of multi-tool.

Contents: 34mm HCS Blade suitable for cutting wood, 87mm HCS Blade suitable for cutting wood, 35mm Carbide Blade suitable for cutting ceramic, 34mm HCS Blade suitable for cutting wood, 50mm Stainless Steel Blade suitable for cutting ceramic, 65mm Carbide Blade suitable for cutting ceramic, 76mm Multi-Tool Triangle Backing Pad



E WMTSET
7pc Multi-Tool Blade Set - Metal & Wood

7-Piece oscillating multifunction tool accessories set. Titanium coated. Supplied in storage case.

Contents: 69mm Bi-Metal blade WMT69 (x2), 34mm Bi-Metal Blade WMT34 (x2), 87mm Radial Bi-Metal blade WMT87 (x1), 44mm Bi-Metal Blade WMT44 (x2)

F SMTA9
82pc Multi-Tool Sanding Set

Turn your multi-tool into the ideal sander with this 82-piece sanding set. Durable and practical. Easily to apply and ideal for general polishing and sanding.

Contents: 80mm Triangle Sanding Pad Holder (x1), 40 x 80mm Triangle Sanding Pads (10pcs each 80, 100, 120, 240Grit), Finger Sanding Pad Holder (x1), Finger Sanding Pads (x40) (10pcs of each 80, 100, 120, 240Grit)

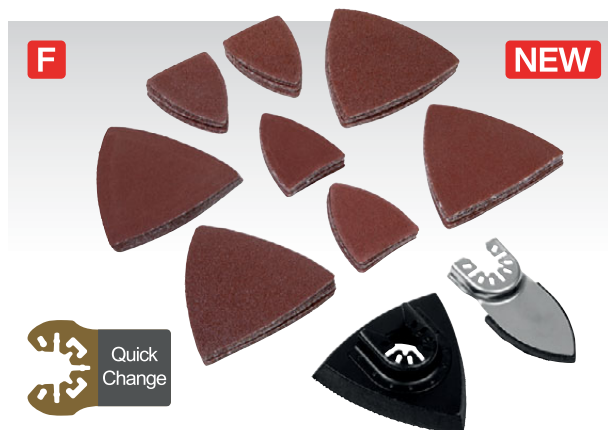

Eye Protection

See pages 1277 to 1279 for our full range of eye protection.

A NEW



A SMTA34W
34mm Multi-Tool Blade Wood
 HCS blade suitable for cutting wood. 1.4mm Teeth. 34mm Cutting length.

Cutting Length:	34mm
Teeth Size:	1.4mm

B NEW



B SMTA41W
41mm Multi-Tool Blade Wood
 HCS blade suitable for cutting wood. 1.7mm Teeth. 41mm Cutting length.

Cutting Length:	41mm
Teeth Size:	1.7mm

C NEW



C SMTA65W
65mm Multi-Tool Blade Wood
 HCS blade suitable for cutting wood. 1.4mm Teeth. 65mm Cutting length.

Cutting Length:	65mm
Teeth Size:	1.4mm

D NEW



D SMTA87W
87mm Multi-Tool Blade Wood
 HCS blade suitable for cutting wood. 1.4mm Teeth. 87mm Cutting length.

Cutting Length:	87mm
Teeth Size:	1.4mm

E NEW



E SMTA34FCW
34mm Multi-Tool Fast Cutting Blade Wood
 HCS blade suitable for cutting wood. Larger 2.5mm teeth pitch allows for faster cutting. 34mm Cutting length.

Cutting Length:	34mm
Teeth Size:	2.5mm

F NEW



F SMTA65FCW
65mm Multi-Tool Fast Cutting Blade Wood
 HCS blade suitable for cutting wood. Larger 2.5mm teeth pitch allows for faster cutting. 65mm Cutting length.

Cutting Length:	65mm
Teeth Size:	2.5mm

G NEW



G SMTA33MW
33mm Multi-Tool Blade Metal & Wood
 Bi-metal blade suitable for cutting soft metals and wood. 1.4mm Teeth. 33mm Cutting length.

Cutting Length:	33mm
Teeth Size:	1.4mm

H NEW



H SMTA44MW
44mm Multi-Tool Blade Metal & Wood
 Bi-metal blade suitable for cutting soft metals and wood. 1.4mm Teeth. 44mm Cutting length.

Cutting Length:	44mm
Teeth Size:	1.4mm

I NEW



I SMTA65MW
65mm Multi-Tool Blade Metal & Wood
 Bi-metal blade suitable for cutting soft metals and wood. 1.2mm Teeth. 65mm Cutting length.

Cutting Length:	65mm
Teeth Size:	1.2mm

J NEW



J SMTA80MW
80mm Multi-Tool Blade Metal & Wood
 HSS metal blade suitable for cutting soft metals and wood. 1.25mm Teeth. 80mm Cutting length.

Cutting Length:	80mm
Teeth Size:	1.25mm

K



K WMT87
87mm Multi-Tool Blade Metal & Wood
 Bi-metal blade suitable for cutting through metal and wood. Titanium coated finish. 87mm cutting length.

Cutting Length:	87mm
-----------------	------



All products on this page are quick change blades.



A NEW



A SMTA50TC
50mm Multi-Tool Blade Ceramic
 Stainless steel blade suitable for cutting ceramic. 50mm Cutting length.

Cutting Length: 50mm

B NEW



B SMTA35TC
35mm Multi-Tool Blade Ceramic
 Carbide blade suitable for cutting ceramic. 35mm Cutting length.

Cutting Length: 35mm

C

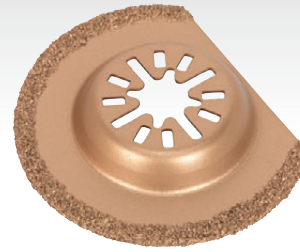

C SMTA3
65mm Multi-Tool Carbide Tipped Half-Moon Cutting Blade

Suitable for cutting channels in porous concrete and removing tile grout. Universal fitting for use with all multi-tools without quick change function.

Cutting Length: 65mm

D NEW



D SMTA65TC
65mm Multi-Tool Blade Ceramic
 Carbide blade suitable for cutting ceramic. 65mm Cutting length.

Cutting Length: 65mm

E NEW

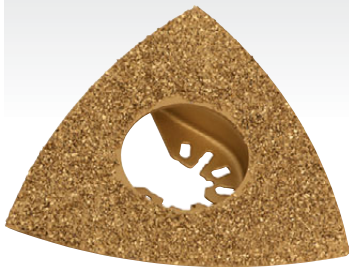

E SMTA78TC
78mm Multi-Tool Blade Ceramic
 Carbide blade suitable for cutting ceramic. 78mm Cutting length.

Cutting Length: 78mm

F NEW



F SMTA94TC
94mm Multi-Tool Blade Ceramic
 Carbide blade suitable for cutting ceramic. 94mm Cutting length.

Cutting Length: 94mm

G NEW



G SMTA60TC
60mm Multi-Tool Blade Ceramic
 Diamond blade suitable for cutting ceramic. 60mm Cutting length.

Cutting Length: 60mm

H



H SMTA4
70mm Multi-Tool Diamond Cutting Blade
 Suitable for ceramic and stone tiles, grout, concrete and masonry. Universal fitting for use with Sealey and other brands of multi-tool (excluding Model No. SMT300Q).

Cutting Length: 70mm

I



I SMTA8
88mm Multi-Tool Triangle Backing Pad
 Multi-tool attachment suitable for a variety of trade applications. Universal fitting for use with all multi-tools without quick change function.

Pad Size: 88 x 88 x 88mm

J NEW



J SMTA12
76mm Multi-Tool Triangle Backing Pad
 Hook-and-loop backing pad for use with Sealey and other brands of multi-tool.

Pad Size: 76 x 76 x 76mm

K



K CP20VMTKIT1
20V 2Ah SV20 Series Cordless Oscillating Multi-Tool Kit
 For full specification see page 854.



Correct Selection Of Blades

For long blade life, it is important to select the correct blade for the material to be cut. As an example, we indicate here the relevant blade selection information for cutting steel (box section, angle iron and C-section):

Material Size:	2-3mm	3-5mm	Over 5mm
Blade tpi:	18-24	14-18	8-14
Blade Speed:	24-71m per minute.		

For information regarding blade selection for other materials, please contact our technical sales team on 01284 757505. Blade breakage caused by incorrect blade selection is not covered by our guarantee.

Personal Protective Equipment

We have a complete range of PPE, see pages 1276 to 1301 for full details.



A

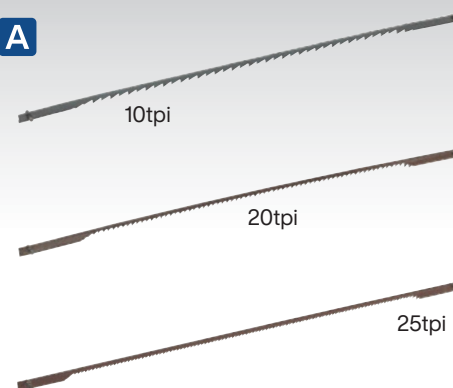

A SEE BELOW

Scroll Saw Blades - Packs of 12

Scroll saw blades with hardened steel teeth suitable for cutting wood, plastics and thin sheet metal.

Model No:	Length:	Pitch:	Pack Qty:
SM43B10	128mm	10tpi	12
SM43B20	128mm	20tpi	12
SM43B25	128mm	25tpi	12

B SEE BELOW

Bandsaw Blades

Flexible bandsaw blades with hardened steel teeth. Suitable for cutting wood, plastics and thin metal sheet.

Model No:	Blade Size:	Pitch:	Application:
SM1303B06	1400 x 6.5mm	6tpi	SM1303
SM1303B10	1400 x 6.5mm	10tpi	SM1303
SM1303B14	1400 x 6.5mm	14tpi	SM1303
SM1303B24	1400 x 6.5mm	24tpi	SM1303
SM1304B06	1712 x 10mm	6tpi	SM1304
SM1304B10	1712 x 10mm	10tpi	SM1304
SM1304B14	1712 x 10mm	14tpi	SM1304
SM1304B24	1712 x 10mm	24tpi	SM1304
SM1305B06	2240 x 12mm	6tpi	SM1305
SM1305B10	2240 x 12mm	10tpi	SM1305
SM1305B14	2240 x 12mm	14tpi	SM1305
SM1305B24	2240 x 12mm	24tpi	SM1305
SM1306B06	2400 x 12mm	6tpi	SM1306
SM1306B10	2400 x 12mm	10tpi	SM1306
SM1306B14	2400 x 12mm	14tpi	SM1306
SM1306B24	2400 x 12mm	24tpi	SM1306

C SEE BELOW

Bandsaw Blades

Suitable for Sealey bandsaws listed below and other popular branded machines.

Model No:	Pitch:	Applications:	Blade Size:
SM5/113/6	6tpi	SM5, SM65	1638 x 13 x 0.63mm
SM5/113/10	10tpi	SM5, SM65	1638 x 13 x 0.63mm
SM5/113	14tpi	SM5, SM65	1638 x 13 x 0.63mm
SM5/113/24	24tpi	SM5, SM65	1638 x 13 x 0.63mm
SM35/B04	4tpi	SM35CE	2362 x 19 x 0.81mm
SM35/B08	8tpi	SM35CE	2362 x 19 x 0.81mm
SM35/B14	14tpi	SM35CE	2362 x 19 x 0.81mm
SM35/B18	18tpi	SM35CE	2362 x 19 x 0.81mm
SM35/B24	24tpi	SM35CE	2362 x 19 x 0.81mm
SM353CE/B04	4tpi	SM353CE	3035 x 25 x 0.89mm
SM353CE/B08	8tpi	SM353CE	3035 x 25 x 0.89mm
SM353CE/B14	14tpi	SM353CE	3035 x 25 x 0.89mm
SM353CE/085	4/6 Vari-Pitch, Bi-Metal	SM353CE	3035 x 25 x 0.89mm
SM354B03	3tpi	SM354CE	2105 x 20 x 0.89mm
SM354B06	6tpi	SM354CE	2105 x 20 x 0.89mm
SM354B14	14tpi	SM354CE	2105 x 20 x 0.89mm
SM354B18	18tpi	SM354CE	2105 x 20 x 0.89mm
SM354B24	24tpi	SM354CE	2105 x 20 x 0.89mm
SM354B610BIM	4/6 Vari-Pitch, Bi-Metal	SM354CE	2100 x 20 x 0.8mm
SM355B14	14tpi	SM355CE	2450 x 27 x 0.9mm

D 5L



D SCS0105

5L Universal Maintenance Fluid with PTFE

Universal maintenance fluid. Protects all metals. Displaces moisture and contains rust inhibitor. Cleans, lubricates and degreases target area. Silicone-free formula suitable for bodyshop use. Ideal for using with small spray trigger bottles.

E

5L



E NCO/5L

5L Neat Cutting Oil

Suitable for lubricating and cooling drill bit, blade or workpiece when cutting mild steel.

F

5L



F SCO/5L

5L Soluble Cutting Oil

Suitable for lubricating and cooling drill bit, blade or workpiece when cutting mild steel.



A

A SEE BELOW
Sanding Discs

Adhesive backed paper sanding discs. Suitable for Sealey disc sanders and other leading brands.

Model No:	Disc Size:	Grit:	Pack Qty:
SSD01	Ø125mm	80	5
SSD02	Ø150mm	80	1
SSD03	Ø230mm	80	1



D-E

D-E SEE BELOW
Ø305mm Sanding Discs

Model No. SSD04 is a hook-and-loop backed sanding disc. Model No. SM31/38 is adhesive backed and is suitable for Model No. SM31 Disc Sander and other brands.

Model No:	Disc Size:	Grit:	Type:
D SSD04	Ø305mm	80	Hook-and-Loop
E SM31/38	Ø305mm	80	Adhesive Backed



G NEW

G SS5ASS
80Grit 5pc Sanding Sleeves

Suitable for use with Model No. SM1300.

Grit:	80Grit
Nominal Size:	Ø13 x 90mm, Ø19 x 90mm, Ø25 x 90mm, Ø38 x 90mm, Ø50 x 90mm

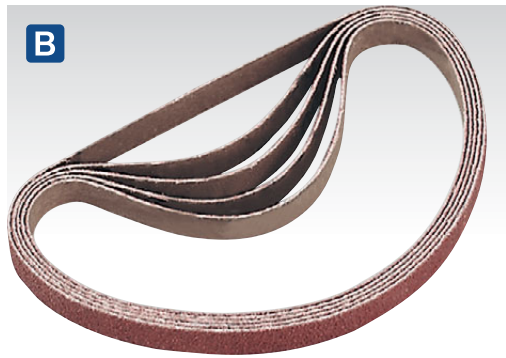

B

B SEE BELOW
Sanding Belts

Aluminium oxide, super-flexible belts. Suitable for Sealey belt sanders and other brands.

Model No:	Nominal Size:	Grit:	Pack Qty:
SA35/B40G	10 x 330mm	40	5
SA35/B60G	10 x 330mm	60	5
SA35/B80G	10 x 330mm	80	5
SA35/B100G	10 x 330mm	100	5
SA35/B120G	10 x 330mm	120	5
SA355/B60G	20 x 520mm	60	5
SA355/B80G	20 x 520mm	80	5
SA355/B100G	20 x 520mm	100	5
SA355/B120G	20 x 520mm	120	5
SBS35/B40GN	8 x 456mm	40	5
SBS35/B40GW	12 x 456mm	40	5
SBS35/B60GN	8 x 456mm	60	5
SBS35/B60GW	12 x 456mm	60	5
SBS35/B80GN	8 x 456mm	80	5
SBS35/B80GW	12 x 456mm	80	5
SBS35/B100GN	8 x 456mm	100	5
SBS35/B100GW	12 x 456mm	100	5
SBS35/B120GN	8 x 456mm	120	5
SBS35/B120GW	12 x 456mm	120	5



F

F SEE BELOW
Sanding Sleeves

Suitable for use with Model No. SM1300 and other leading brands of Spindle Sanders.

Model No:	Nominal Size:	Grit:
SM1300B25	Ø25 x 90mm	80
SM1300B38	Ø38 x 90mm	80
SM1300B50	Ø50 x 90mm	80



C

C SEE BELOW
Sanding Belts

Aluminium oxide, super-flexible sanding belts. Suitable for Sealey belt sanders and other brands.

Model No:	Nominal Size:	Grit:	Pack Qty:
SB0010	30 x 540mm	60	5
SB0011	30 x 540mm	80	5
SB0012	100 x 1220mm	80	1
SB0013	100 x 1220mm	100	1
SB0014	100 x 915mm	60	1
SB0015	100 x 915mm	80	1
SB0016	100 x 915mm	100	1
SB0017	150 x 1220mm	80	1
SB0018	150 x 1220mm	100	1
SB0019	25 x 762mm	120	5
SB0020	25 x 762mm	60	5
SB0021	25 x 762mm	80	5
SB0022	20 x 100mm	80	1
SB005	50 x 686mm	120	5
SB006	50 x 686mm	60	5
SB007	50 x 686mm	80	5
SB008	30 x 540mm	100	5
SB009	30 x 540mm	40	5
SM1300B610	610 x 100mm	80	1
WSB53245	75 x 533mm	24	5
WSB5340	75 x 533mm	40	10
WSB5360	75 x 533mm	60	10
WSB5380	75 x 533mm	80	10
WSB53100	75 x 533mm	100	10
WSB53120	75 x 533mm	120	10
CB16124/3	100 x 610mm	24	3
CB16140/3	100 x 610mm	40	3
CB16180/3	100 x 610mm	80	3
CB161120/3	100 x 610mm	120	3
CB161A/3	100 x 610mm	40, 80, 120	3
WSB61245	100 x 610mm	24	5
WSB6140	100 x 610mm	40	10
WSB6160	100 x 610mm	60	10
WSB6180	100 x 610mm	80	10
WSB61100	100 x 610mm	100	10
WSB61120	100 x 610mm	120	10
WSB62245	100 x 620mm	24	5
WSB62365	100 x 620mm	36	5
WSB6240	100 x 620mm	40	10
WSB6260	100 x 620mm	60	10
WSB6280	100 x 620mm	80	10
WSB62100	100 x 620mm	100	10
WSB62120	100 x 620mm	120	10
WSB62150	100 x 620mm	150	10



A NEW



A SMTA11
9pc 76mm Multi-Tool Sanding Sheet Set

9-Piece sanding set for the Sealey Model No. CP108VMTBO and other compatible multi-tools. Hook-and-loop backed for fast and easy changes during use. Featuring multiple grit sizes to finish off most sanding jobs. Includes three of each 60, 80 and 120Grit paper.

Size:	76 x 76 x 76mm
Grit:	60, 80, 120 (3 of each)
Pack Qty:	9

D NEW



D SMTA9
82pc Multi-Tool Sanding Set

Turn your multi-tool into the ideal sander with this 82-piece sanding set. Durable and practical. Easy to apply and ideal for general polishing and sanding.

Contents: 80mm Triangle Sanding Pad Holder (x1), 40 x 80mm Triangle Sanding Pads (10pcs each 80, 100, 120, 240Grit), Finger Sanding Pad Holder (x1), Finger Sanding Pads (x40) (10pcs of each 80, 100, 120, 240Grit)

B



B SMTA7
20pc 90mm Multi-Tool Sanding Sheet Set

Includes 5-piece of each grit P60, P80, P120 and P240 with hook-and-loop backing. Suitable for use with Sealey Model No. SMTA8 backing pad.

Size:	90 x 90 x 90mm
Grit:	P60, P80, P120, P240 (5 of each)

E NEW



E SSDS01
10pc Ø150mm Hook-and-Loop Sanding Disc Set

Hook-and-loop sanding discs suitable for all wood types. Ideal for sanding paint, varnish, filler and smoothing out edges. Hook-and-loop backed for easy installation and removal. Compatible with most Ø150mm disc sanders with a hook-and-loop backing pad including Sealey Model No. CP108VSPBO and other leading brands. Includes grit sizes T60 (x2), T120 (x4), T240 (x4).

Disc Size:	Ø150mm
Grit:	T60 (x2), T120 (x4), T240 (x4)
Pack Qty:	10

C NEW

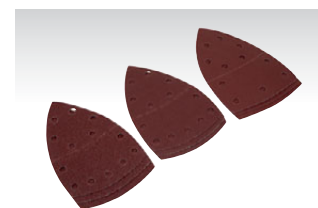

C SMTA10
9pc Detail Sander Sanding Sheet Set

9-Piece Sanding Set for the Sealey Model No. CP108VDSBO and other compatible multi-tools. Hook-and-loop backed for fast and easy changes during use. Featuring multiple grit sizes to finish off most sanding jobs.

Size:	150 x 150 x 100mm
Grit:	60, 120, 240 (3 of each)
Pack Qty:	9

F NEW

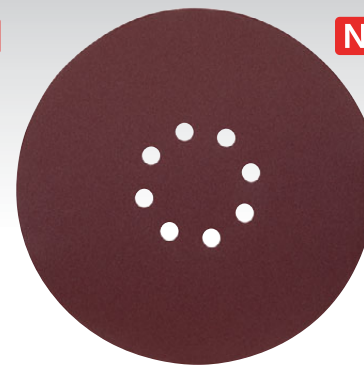

F SSD05
5pc Ø225mm Hook-and-Loop Sanding Disc Set

Hook-and-Loop Sanding discs suitable for use with Sealey Drywall Sanders. Ideal for sanding paint, varnish, filler and smoothing out edges. Hook-and-loop backed for easy installation and removal. Compatible with most Ø215-225mm disc sanders with a hook-and-loop backing pad including Sealey Model No's TDWS600, DWS215 and other leading brands. Includes five grit sizes between 60-180Grit.

Disc Size:	Ø225mm
Grit:	60, 80, 120, 150, 180 (1 of each)
Pack Qty:	5

A



A SEE BELOW

Fibre Backed Sanding Discs

Abrasive fibre backed sanding discs for use with portable disc sanders. Suitable for working on wood or metal surfaces.

Model No:	Diameter:	Grit:	Pack Qty:
WSD424	Ø100mm	24	25
FBD10036	Ø100mm	36	25
WSD440	Ø100mm	40	25
FBD10050	Ø100mm	50	25
WSD460	Ø100mm	60	25
WSD480	Ø100mm	80	25
WSD4120	Ø100mm	120	25
WSD4524	Ø115mm	24	25
FBD11536	Ø115mm	36	25
WSD4540	Ø115mm	40	25
FBD11550	Ø115mm	50	25
WSD4560	Ø115mm	60	25
WSD4580	Ø115mm	80	25

Model No:	Diameter:	Grit:	Pack Qty:
WSD45120	Ø115mm	120	25
WSD524	Ø125mm	24	25
WSD540	Ø125mm	40	25
WSD560	Ø125mm	60	25
WSD580	Ø125mm	80	25
WSD5120	Ø125mm	120	25
WSD724	Ø175mm	24	25
WSD740	Ø175mm	40	25
WSD760	Ø175mm	60	25
WSD780	Ø175mm	80	25
WSD7120	Ø175mm	120	25

B



5m 10m

B SEE BELOW
Sanding Rolls

Long lasting, heavy backing paper, suitable for orbital sanders.

Model No:	Width:	Length:	Grit:
WSR560	115mm	5m	60
WSR5120	115mm	5m	120
WSR5180	115mm	5m	180
WSR5240	115mm	5m	240
WSR1040	115mm	10m	40
WSR1060	115mm	10m	60
WSR1080	115mm	10m	80
WSR10120	115mm	10m	120
WSR10180	115mm	10m	180
WSR10240	115mm	10m	240

E



E SEE BELOW
450g Steel Wool

Quality steel wool supplied in 450g roll.

Model No:	Grade:	Weight
SW00	#00 Extra Fine	450g
SW0	#0 Fine	450g
SW1	#1 Medium	450g
SW3	#3 Coarse	450g

C

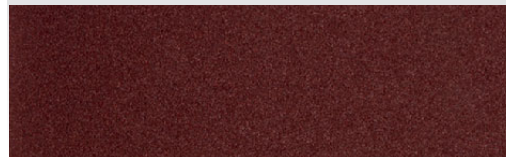

C SEE BELOW

115 x 280mm Orbital Sanding Sheets
Packs of 5

For use on most brands of half sheet orbital sanders. Suitable for sanding wood, plaster, paint, metal and fillers.

Model No:	Size:	Grit:	Pack Qty:
CS11540/5	115 x 280mm	40	5
CS11560/5	115 x 280mm	60	5
CS11580/5	115 x 280mm	80	5
CS115100/5	115 x 280mm	100	5
CS115120/5	115 x 280mm	120	5
CS115A/5	115 x 280mm	ASSORTED	5

F



50m

F SEE BELOW

25mm x 50m Engineer's Emery Rolls Brown

Engineering grade brown emery roll, ideal for hand operation.

Model No:	Width:	Length:	Grit:
ERB255080	25mm	50m	80
ERB2550120	25mm	50m	120

D

NEW



50m

D ERB5050320

50mm x 50m Engineer's Emery Roll Brown - 320Grit

Engineering grade brown emery roll, ideal for hand operation. Designed for rust removal, finishing and polishing. Not for use on wood. Supplied in a dispenser box.

Grit:	320
Length:	50m

G



50m

G SEE BELOW

50mm x 50m Engineer's Emery Rolls Brown

Engineering grade brown emery roll, ideal for hand operation.

Model No:	Width:	Length:	Grit:
ERB505080	50mm	50m	80
ERB5050120	50mm	50m	120

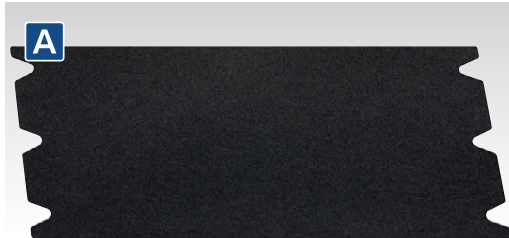

A SEE BELOW

Floor Sanding Sheets - Packs of 25

Silicon carbide paper. Suitable for renovating, sanding and fine finishing on wooden floors.

Model No:	Size:	Grit:	Pack Qty:
DU824EM	205 x 470mm	24	25
DU836EM	205 x 470mm	36	25
DU840EM	205 x 470mm	40	25
DU860EM	205 x 470mm	60	25
DU880EM	205 x 470mm	80	25
DU8100EM	205 x 470mm	100	25
DU8120EM	205 x 470mm	120	25



B SEE BELOW

Floor Sanding Sheets - Packs of 25

Heavy-duty silicon carbide paper. Suitable for renovating, sanding and fine finishing on wooden floors. For use with rotary drum sanders such as Clarke DU8, Clarke E2-8 and Hiretech HT-8.

Model No:	Size:	Grit:	Pack Qty:
DU824	205 x 470mm	24	25
DU824OC*	205 x 470mm	24	25
DU836	205 x 470mm	36	25
DU840	205 x 470mm	40	25
DU860	205 x 470mm	60	25
DU880	205 x 470mm	80	25
DU8100	205 x 470mm	100	25
DU8120	205 x 470mm	120	25

*DU824OC is open coat.

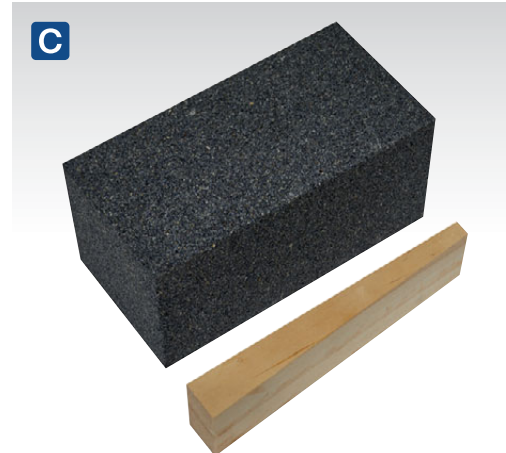

C SEE BELOW

Floor Grinding Blocks - Packs of 6

Silicon carbide floor grinding blocks with wooden wedges. Ideal for aggressive grinding performance for the preparation and grinding of concrete floors.

Model No:	Size:	Grit:	Pack Qty:
FGB12	50 x 50 x 100mm	12	6
FGB24	50 x 50 x 100mm	24	6
FGB36	50 x 50 x 100mm	36	6
FGB60	50 x 50 x 100mm	60	6
FGB120	50 x 50 x 100mm	120	6

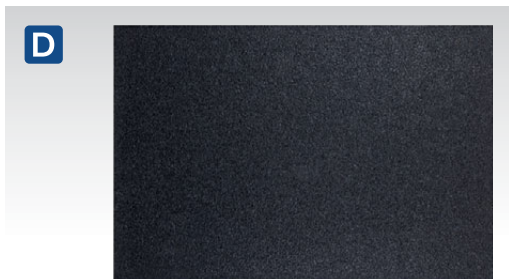

D SEE BELOW

12 x 18" Orbital 1/2 Sheets - Packs of 20

General-purpose sanding sheets. Suitable for sanding on wood, plaster, paint, metal and fillers. For use with orbital sander brands such as Essex, Squarbuff, Orbitec, Starbuff and Clarke.

Model No:	Size:	Grit:	Pack Qty:
OSS121820	12 x 18"	20	20
OSS121836	12 x 18"	36	20
OSS121860	12 x 18"	60	20
OSS121880	12 x 18"	60	20
OSS1218100	12 x 18"	100	20



E RBP1218

12 x 18 x 1" Red Cleaning & Buffing Pads Pack of 5

Suitable for dry or spray buffing. For general cleaning of scuff marks and dirt while restoring gloss. Can be used on concrete, hardwood and tile.



F TBP1218

12 x 18 x 1" Tan Buffer Pads - Pack of 5

Suitable for light cleaning and dry buffing. Can be used on concrete, hardwood and tile.



G SEE BELOW

12 x 18" Mesh Screen Sheets - Packs of 10

Buffing screen sheets. Suitable to be used between coats of finish to remove raised grains of wood. For use with orbital sander brands such as Essex, Squarbuff (Square Buff), Orbitec, Starbuff and Clarke.

Model No:	Size:	Grit:	Pack Qty:
MOS121860	12 x 18"	60	10
MOS121880	12 x 18"	80	10
MOS1218100	12 x 18"	100	10
MOS1218120	12 x 18"	120	10
MOS1218150	12 x 18"	150	10



H WPP1218

12 x 18 x 1" White Polishing Pads Pack of 5

Suitable for polishing on clean and dry wood floors. Can be used on concrete, hardwood and tile.



I GSP1218

12 x 18 x 1" Green Scrubber Pads Pack of 5

Durable heavy-duty pad suitable for wet scrubbing and light stripping. Can be used on concrete, hardwood and tile.

J BSP1218

12 x 18 x 1" Black Stripping Pads - Pack of 5

Durable heavy-duty pad suitable for wet stripping. For the removal of wax, dirt and any finish. Can be used on concrete, hardwood and tile.

Model No's **D - J** are suitable for use with orbital sander brands such as Essex, Squarbuff (Square Buff), Orbitec, Starbuff and Clarke.



Colour Guide

Each colour represents a different foam density. The chart below details which colour head to use for which job.

RED FOAM

Ultra-soft foam for final finish. Ideal for car valeting.

WHITE FOAM

Dense and firm. Ideal for compounding all modern paint systems.

BLACK FOAM

Soft polishing foam. Ideal for work on dark colours.

YELLOW FOAM

Coarse foam with open cell for aggressive jobs. Ideal for LV paint.

BLUE FOAM

Medium density, all-purpose foam.

ORANGE FOAM

Firm density.

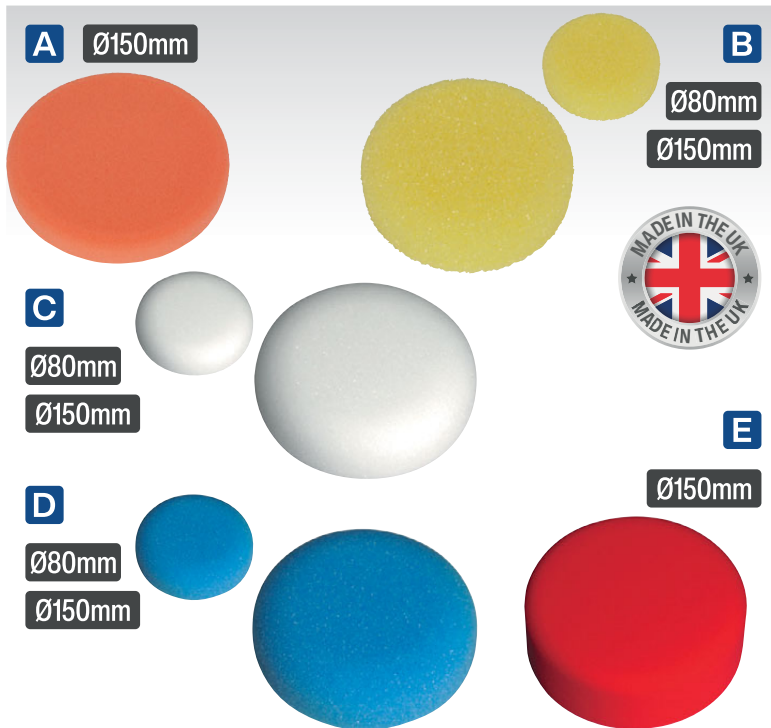

A-E SEE BELOW

Hook-and-Loop Buffing & Polishing Foam Heads

Model No:	Size:	Colour/Type:
A PTCCHV150O	Ø150 x 25mm	Orange/Firm
B PTCCHV79Y	Ø80 x 25mm	Yellow/Coarse
B PTCCHV150Y	Ø150 x 50mm	Yellow/Coarse
C PTCCHV79W	Ø80 x 25mm	White/Dense
C PTCCHV150W	Ø150 x 50mm	White/Dense
D PTCCHV79B	Ø80 x 25mm	Blue/Medium
D PTCCHV150B	Ø150 x 50mm	Blue/Medium
E PTCCHV150R	Ø150 x 50mm	Red/Ultra-Soft

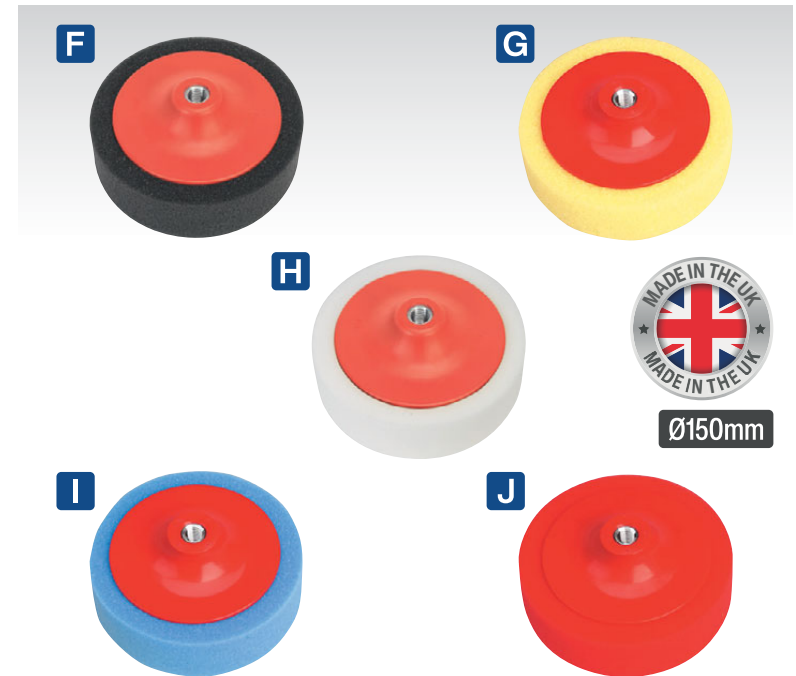

F-J SEE BELOW

Buffing & Polishing Foam Heads

Model No:	Size:	Thread:	Colour/Type:
F PTC/CH/M14-P	Ø150 x 50mm	M14 x 2mm	Black/Soft
G PTC/CH/M14-Y	Ø150 x 50mm	M14 x 2mm	Yellow/Coarse
H PTC/CH/M14-W	Ø150 x 50mm	M14 x 2mm	White/Dense
H PTC/CH/5/8-W	Ø150 x 50mm	5/8"UNC	White/Dense
I PTC/CH/M14-B	Ø150 x 50mm	M14 x 2mm	Blue/Medium
I PTC/CH/5/8-B	Ø150 x 50mm	5/8"UNC	Blue/Medium
J PTC/CH/M14-R	Ø150 x 50mm	M14 x 2mm	Red/Ultra-Soft



K SEE BELOW

Universal DA Dust-Free Backing Pads

Suitable for air and electric tools fitted with 5/16"UNF or M8 threads.

Model No:	Pad Size:	Thread:	Suitability:
AK289	Ø150mm	5/16"UNF & M8	Stick-on
AK290	Ø150mm	5/16"UNF	Hook-and-Loop
PTC150MH	Ø150mm	5/16"UNF	Hook-and-Loop



L SEE BELOW

Ø150mm Buffing & Polishing Foam Heads

Manufactured from European foam. Suitable for buffing and polishing vehicle bodywork. Supplied with M14 x 2mm female thread.

Model No:	Type:	Size:	Thread:
PTC150CHM	Medium	Ø150 x 50mm	M14 x 2mm
PTC150CHS	Soft	Ø150 x 50mm	M14 x 2mm

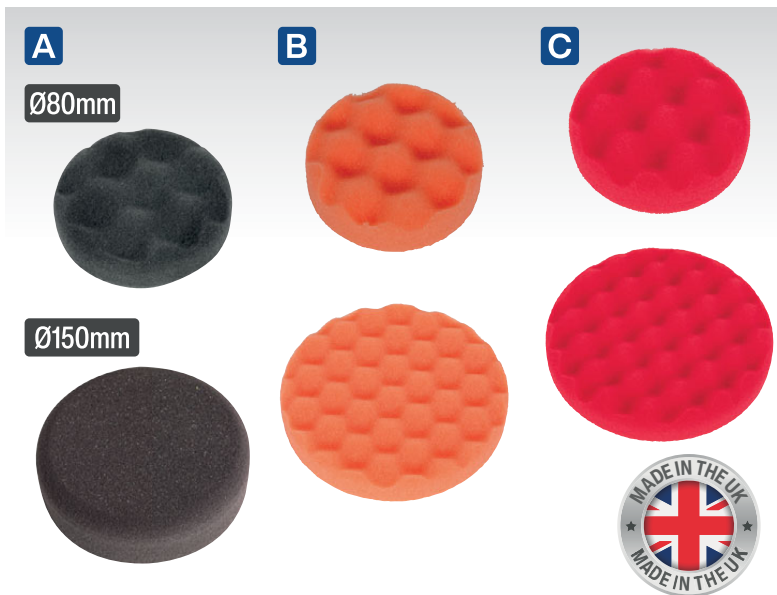

A-C SEE BELOW

Hook-and-Loop Compounding/Buffering and Polishing Foam Heads

Model No:	Size:	Colour/Type:
A PTCCHV79P	Ø80 x 25mm	Black/Soft
A PTCCHV150P	Ø150 x 50mm	Black/Soft
B PTCCHW80O	Ø80 x 25mm	Orange/Firm
B PTCCHW150O	Ø150 x 25mm	Orange/Firm
C PTCCHW80R	Ø80 x 25mm	Red/Ultra Soft
C PTCCHW150R	Ø150 x 25mm	Red/Ultra Soft

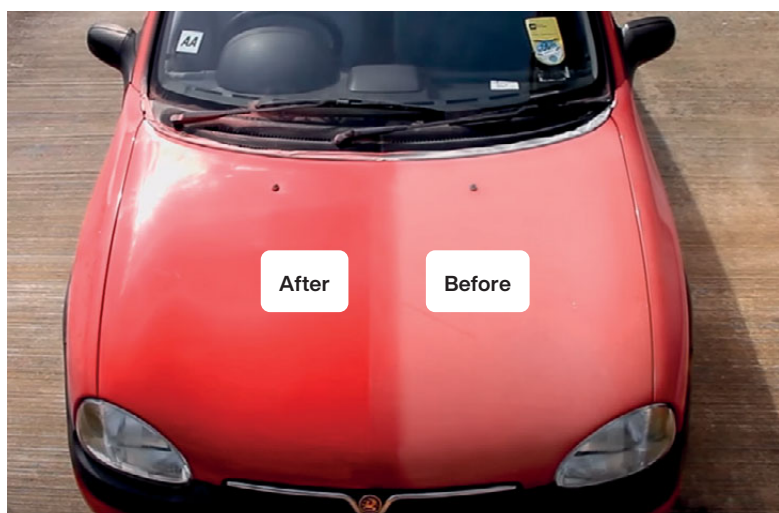

D PTCCHC850

Buffing & Polishing Foam Cone Orange/Firm

Foam polishing cone holds compound for clean and precise application to workpiece. Allows difficult areas to be reached, such as between spokes and in recesses on alloy wheels. Suitable for use with Sealey Model No. CP2812V and other brands of mini polishers.

Size:	Ø35-Ø84 x 82mm
Thread Size:	1/4"UNC

POLISHERS
For our full range of Polishers, see pages 882 to 884.



E-F SEE BELOW

10mm Polisher Pad Kits

Assorted packs containing six different types of 10mm pads. Contents: Green Foam (x2), Blue Foam (x2), Orange Foam (x2), Red Foam (x2), Microfibre Pad 6mm (x2), Wool Pad (x2). Colour guide is as follows: Green is firm and for heavy cutting, blue is medium density all-purpose foam, orange is for polishing, red is soft foam for a final finish, microfibre is slightly more aggressive than foam but is also a finishing pad.

Model No:	Size:
E SPK600ACC1	Ø40 x 10mm
F SPK600ACC2	Ø56 x 10mm



G SCS700

500ml Fine Cutting Compound

Fine cutting compound will help to restore gloss and remove moderate swirl marks and fine scratches in all paintwork, without drying out or generating a large amount of polishing dust.

Size:	500ml
--------------	-------



H SCS701

500ml Medium Cutting Compound

Medium cutting compound will help to restore gloss and remove moderate swirl marks and fine scratches in all paintwork, without drying out or generating a large amount of polishing dust.

Size:	500ml
--------------	-------



I SCS702

500ml Super Polymer Polish

Super polymer polish helps to protect and restore gloss paintwork. For use with dual action and rotary polishers. Contains premium carnauba wax for unsurpassable shine. Built-in salt inhibitor builds a durable coating for long term lustre, with repeated use.

Size:	500ml
--------------	-------

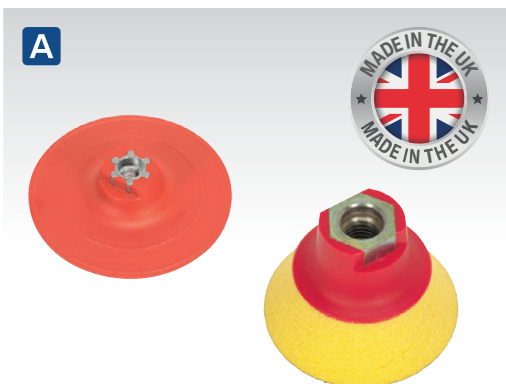

A SEE BELOW
Hook-and-Loop Backing Pads

Hook-and-loop faced pads suitable for use with hook-and-loop backed buffing and polishing foam heads.

Model No:	Pad Size:	Type:	Thread:
PTCBPV3	Ø117mm	Hard	M14 x 2mm
PTCBPV4	Ø75mm	Hard	M14 x 2mm
PTCBPV3S	Ø123mm	Ultra-Soft	M14 x 2mm
PTCBPV4S	Ø70mm	Ultra-Soft	M14 x 2mm



E SEE BELOW
5/16"UNF DA Backing Pads

Suitable for Ø150mm abrasive discs.

Model No:	Pad Size:	Type:	Thread:
PTC115VA516	Ø115mm	5/16UNF	Ø115mm Hook-and-Loop (Firm)
PTC/150SA	Ø145mm	5/16UNF	Ø115mm Stick-on (Soft)
PTC/150VA	Ø145mm	5/16UNF	Ø115mm Hook-and-Loop (Firm)

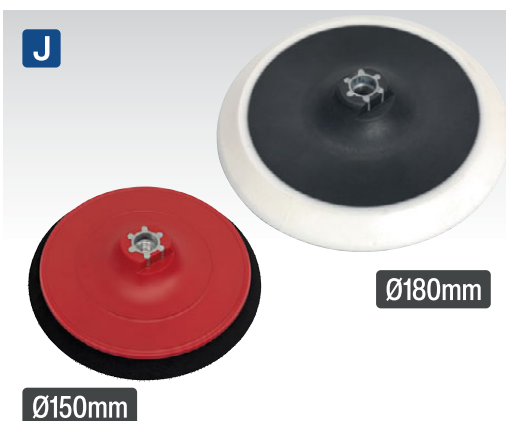

J SEE BELOW
Hook-and-Loop Backing Pads - M14

Suitable for air and electric tools fitted with M14 thread.

Model No:	Pad Size:	Thread:
PTC/150VA/M14	Ø148mm	M14 x 2mm
PTC/180VA	Ø178mm	M14 x 2mm



B SEE BELOW
Hook-and-Loop Backing Pads

Model No:	Pad Size:	Type:	Thread:
PTC50VA516	Ø50mm	Male	5/16"UNC
PTC50VAM6	Ø50mm	Male	M6 x 1mm
PTC75VA	Ø71mm	Female	1/4"UNC
PTC75VA516	Ø71mm	Male	5/16"UNC
PTC75VAM6	Ø71mm	Male	M6 x 1mm
PTC75VAM14	Ø75mm	Male	1/4"UNC
PTC75VM10	Ø75mm	Female	M10 x 1.5mm
PTC75HLM	Ø75mm	Male	6mm Shaft



F PTC150DFV
Ø145mm DA Dust-Free Backing Pad for Hook-and-Loop Discs 5/16"UNF

Suitable for air and electric tools fitted with 5/16"UNF threads.

Pad Size:	Ø145mm (Firm)
Thread Size:	5/16"UNF
Suitability:	Ø150mm Hook & Loop



K ER/MS/66
Ø180mm Tie Cord Polishing Bonnet

Suits all makes of electric and air polishing machines. Uses 100% pure new wool pile to obtain a professional deep polishing effect.

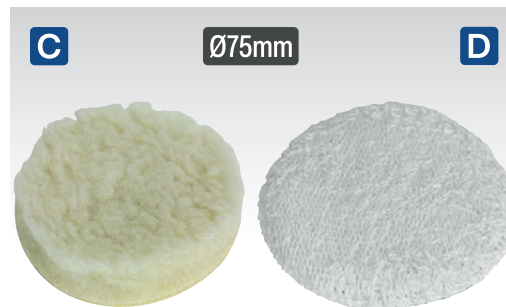

C-D SEE BELOW
Ø75mm Hook-and-Loop Accessories

Suitable for use with Ø75mm backing pads.

Polishing Mop	
C Model No:	PTCPM75
Size:	Ø75mm
Microfibre Cloth	
D Model No:	PTCMC75
Size	Ø75mm



G-I SEE BELOW
Ø150mm Hook-and-Loop Accessories

Suitable for use with Ø150mm backing pads.

Model No:	Description:
G PTC150M6	Backing Pad M6 x 1mm
H PTCMC150	Terry Bonnet Pad
I PTCWB150	Polishing Bonnet



L PTCPB100
Ø100mm Polishing Ball

Manufactured from soft non-woven fabric. Ideal for cleaning in and around alloy wheels. Suitable for use with air or electric drills.

Size:	Max Speed:	Shaft Size:
Ø100mm	35000rpm	Ø11mm